

2025/2026



**ST
R
S**

NEW PRODUCTS



XT53.3RD

More info at page **26**



XT90.3

More info at page **22**



JR66 + JR84

More info at page **27**



V-CAM R814

More info at page **44-45**



XXL BLOCKS

More info at page **78-79**



FB32 + FB42

More info at page **169-171**



DS06, DS08 & DS10

More info at page **187**

INDEX

WINCHES

4

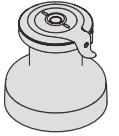

CLUTCHES

36

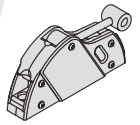

BLOCKS

56



CARS *T-TRACK*

110

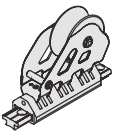

CARS *BALL BEARING*

126

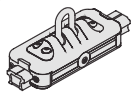

FULL BATTEN *SYSTEMS*

154



SOFT LINKS & ACCESSORIES

184





WINCHES



Standard

8



XT Self-Tailing

10



Electric

14



Hydraulic

20



Maxi

22



XT Racing

24



JR line

27



Pedestals

28



Classic

30



Line Driver

31



Powered Line Driver

32



Winch handles

34

TECHNICAL INFOS

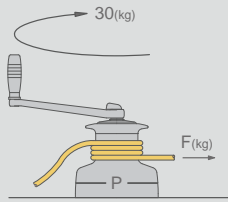

WINCH POWER AND MAXIMUM FORCE

To calculate the maximum force (F), first use the tables to find winch power (P). Assuming the efficiency is 70% and the maximum force exerted on the handle is 30 kg, the maximum force obtainable will be: $F = 20 \times P$ (kg) i.e. twenty times the winch power. For example, for a model with a winch power 50, the maximum force would be $F = 20 \times 50 = 1000$ Kg.

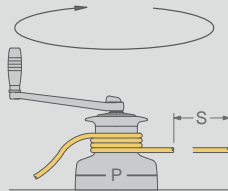

RECOVERY SPEED

The recovery speed (S) is the length of line recovered with one turn of the handle. It is the converse of the winch power (P), and can be calculated using the formula: $S = 1600/P$ (mm) For example, a model with winch power 50 would have a recovery speed of $S = 1600/50 = 32$ mm for each 360° turn of the handle.

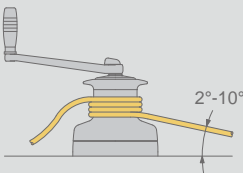

WINCH MOUNTING

Line drum lead angle: it is correct to provide an angle of between 2 and 10 degrees. It is advisable for the output gear of 2 speed models to be positioned with respect to pull direction, as shown in the figure (90°).

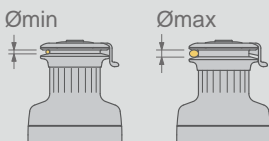
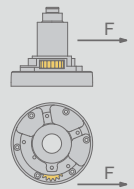

SPRING-LOADED SELF-TAILING

The new Self-Tailing winches with spring-loaded disks adapt automatically to even the thinnest lines. We recommend to put three or four wraps of line on the drum, otherwise excessive load on the Self-Tailing disks could cause the line to slip.

MAINTENANCE

Clean the winch by removing any old grease with a solvent (e.g. using diesel fuel). Spread a thin layer of marine grease on all moving parts. Grease will protect aluminium from corrosion (where contact with dissimilar metal occurs). It is useful to use some grease especially on stainless steel screws, threads and stainless washers. For a complete documentation ask for the "Winch User's Guide".

LUBRICATION

Antal uses Hydrolub (**MOD. HDR**) for winch and gear lubrication. This grease can be supplied (in 150 gr tubes) on request.

SPARE PARTS

Antal can supply you with a universal repair kit (**MOD. XTKIT**) suitable for all winch types, including 4 pawls and 4 pawl springs.



WINCH SELECTION GUIDE



↓ MASTHEAD RIG

LOA up to m	7	8	9	10	11	12	13	14	15	16	18	21
LOA up to ft	23	26	30	33	36	39	43	46	49	53	60	76
GENOA m²	18	24	32	40	50	63	78	92	110	130	180	230
MAIN m²	12	14	16	18	23	29	35	42	52	65	80	100
SPIN m²	28	40	55	75	92	120	150	185	225	270	360	460

↓ WINCH POWER

GENOA SHEET	8 / 16	16 / 30	30 / 40	40 / 44	44 / 48	52	62	66	66	76	76	80
MAIN SHEET	-	-	-	-	16	30	30 / 40	40	44	52	62	66
SPIN SHEET	7 / 8	8 / 16	16 / 30	30	40	44	48	48	52	62 / 66	66	76
GENOA HALYARD	7 / 8	8	16	30	30 / 40	40 / 44	44	44	48	52	62	66
MAIN HALYARD	7 / 8	8	16	30	40	44	44	44 / 48	48	52	62	66
SPIN HALYARD	7 / 8	8	16	16	30	40	44	44	48	52	62	66
TOPPING LIFT	-	-	8	8	16	30	30 / 40	40	44	48	52	62
FOREGUY	-	-	8	8	16	30	30 / 40	40	44	48	52	62
REEFING	-	8	8	16	30	40	40 / 44	40 / 44	48	52	62	66
VANG	-	-	-	8	8	16	30	30	40	44	52	62
RUNNERS	-	-	-	-	8	16	16	30 / 40	40	44	52	62



↓ FRACTIONAL RIG

LOA up to m	7	8	9	10	11	12	13	14	15	16	18	21
LOA up to ft	23	26	30	33	36	39	43	46	49	53	60	76
GENOA m²	10	15	23	30	38	47	56	63	72	79	95	120
MAIN m²	14	17	24	32	40	49	57	65	75	82	100	130
SPIN m²	22	34	52	68	88	105	122	140	158	175	210	270

↓ WINCH POWER

GENOA SHEET	8	16	30	40	44	48	52	62	62 / 66	66	66 / 76	76
MAIN SHEET	-	-	-	-	16	30	40	44	48	52	66	66
SPIN SHEET	7 / 8	8	16	30	40	40	44	44 / 48	48	62	66	66
GENOA HALYARD	7	8	16	16	30	40	44	44	48	52	62	66
MAIN HALYARD	7 / 8	8	16	30	30 / 40	40 / 44	44	48	48	52	62	66
SPIN HALYARD	7 / 8	8	16	16	30	40	40	44	48	48	62	62
TOPPING LIFT	-	-	8	8	16	16	30	40	44	44	48	52
FOREGUY	-	-	8	8	16	16	30	40	44	44	48	52
REEFING	-	8	16	16	30	40	40	44	48	52	62	66
VANG	-	-	-	8	16	30	30	40	44	44	52	62
RUNNERS	-	16	30	40	40 / 44	44	48	52	62	66	66	76

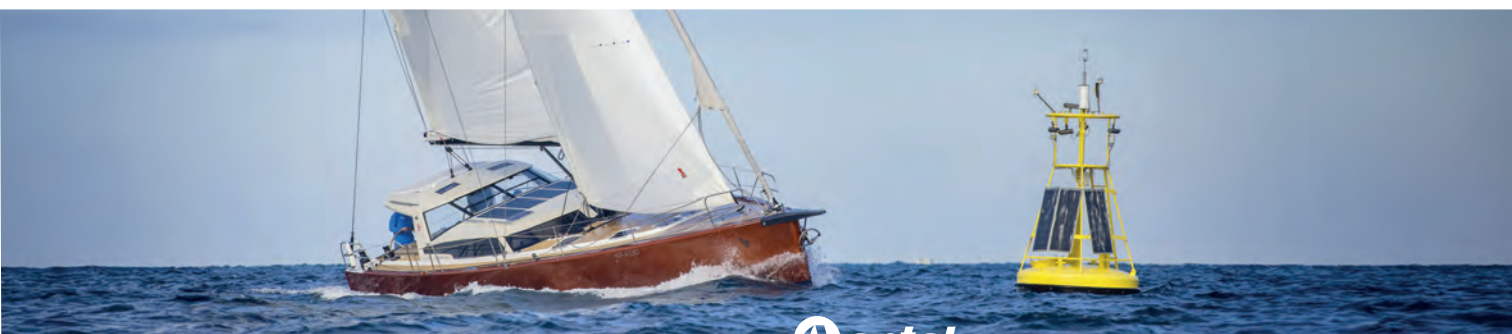

STANDARD WINCHES

STANDARD WINCHES

There are three series of standard winches.

- One direct speed winches, small and fast models for boats up to 6-7m.
- Two speed winches, direct and reduced: medium size models for boats up to 9-10m.
- Two reduced speed winches, medium-large size models for boats up to 12-13m.

SNUBBING WINCH

→ W5

Basic model, snubbing winch without handle, completely glass-fiber resin made.

MODEL	W5
BASE mm	80
HEIGHT mm	66
WEIGHT g	193
SCREWS N x Ø mm	4 x Ø 6



MOD. W5

ONE DIRECT SPEED WINCHES

→ W6, W7, W8

Turn the handle clockwise to engage the single direct gear; the handle turns freely counter-clockwise.

- **MOD. W6** is the smallest and lightest in the range, with a glass-fibre resin base and drum and an aluminium central rod.
- **MOD. W7** is similar but with a hard black anodized aluminium drum.
- **MOD. W8** has an AISI316 stainless steel central rod, an aluminium base and a black anodized aluminium (**AL**) or chrome-plated (**CH**) drum mounted on roller bearings.



MOD. W8AL + MOD. W8CH

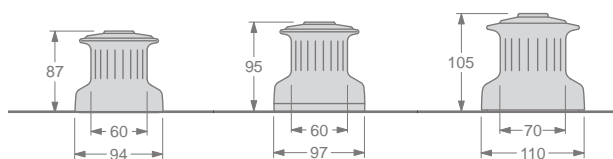

↓ ONE SPEED WINCHES

MODEL	W6	W7	W8
POWER P1	6.7	6.7	7.3
RECOVERY S1 mm	188	188	220
WEIGHT AL kg	0.43*	0.70	1.60
WEIGHT CH kg	-	-	2.10
SCREWS N x Ø mm	5 x Ø6	5 x Ø6	5 x Ø6

* Glass fibre resin drum.
For **MOD. W6** and **W7** winch power is calculated with short handle (L – 200 mm).

TWO SPEED WINCHES: DIRECT, REDUCED

→ W16, W30, W42

The first speed is direct (one turn of the drum for each turn of the handle); the second speed is reduced: slower but more powerful.

Bronze base and gears, AISI316 stainless steel central rod and roller bearings, and black anodized aluminium (**AL**) or chrome-plated (**CH**) drums.



MOD. W42AL + MOD. W42CH

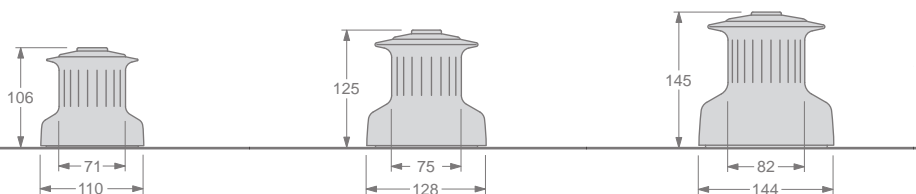

↓ TWO SPEED WINCHES

MODEL	W16	W30	W42
POWER P1-P2	7.3 / 14.5	7.0 / 28.0	6.4 / 42.5
RECOVERY S1-S2 mm	220 / 110	235 / 60	250 / 37
WEIGHT AL kg	2.00	2.80	4.10
WEIGHT CH kg	2.90	3.80	6.00
SCREWS N x Ø mm	5 x Ø6	5 x Ø6	5 x Ø8

P1-P2: power with the first (fast) and second (slow) gear.

S1-S2: recovery speed, the length of line recovered with one turn of the handle in first gear and in second gear.

Namib 2



XT WINCHES



Simple opening



New XT system



Vertical knurling

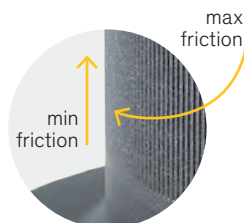

CNC base



15 NEW SELF-TAILING WINCHES AVAILABLE IN THE FOLLOWING VERSIONS

HARD BLACK ALUMINIUM (AL): the aluminium drum is hard black anodized and teflon coated, scratch-proof and very hard-wearing (page 12-13).

CHROME (CH): the drum, ST disks and ST arm are entirely chrome-plated. All chromed parts are highly polished, thickly nickel-plated and finally finished in chrome (pages 12-13).

RACE (R): racing series obtained by lightening the previous series AL (page 24).

CLASSIC (CHC and BNC): fully chromed or with natural bronze finish (page 30). Moreover an electric and hydraulic powered series are also available. (page 16-21) Antal winches have a three-year warranty.

SIMPLE OPENING: just unscrew the upper ring to immediately dismantle the winch for an easy of cleaning and maintenance.

NEW SELF-TAILING XT SYSTEM: fixed upper disk with built in ST arm and self-regulating lower disk on

springs. The new Self-Tailing adapts automatically to a wide range of rope diameters and, if overloading occurs, releases the line to avoid excess force on the ST arm.

KNURLING: the drum vertical knurling offers maximum horizontal friction allowing the rope "slide" upwards. Differentiated grip (aluminium drums only): minimum friction on the lower part where loads are higher and maximum at the top where loads are minimal: the result is an even grip along the entire drum.

CNC BASE: machined by CNC (computer numeric control machines) is lighter and stronger than normal castings; aluminium made, hard black anodized and teflon coated. Easy removal from the winch makes maintenance a simple affair.

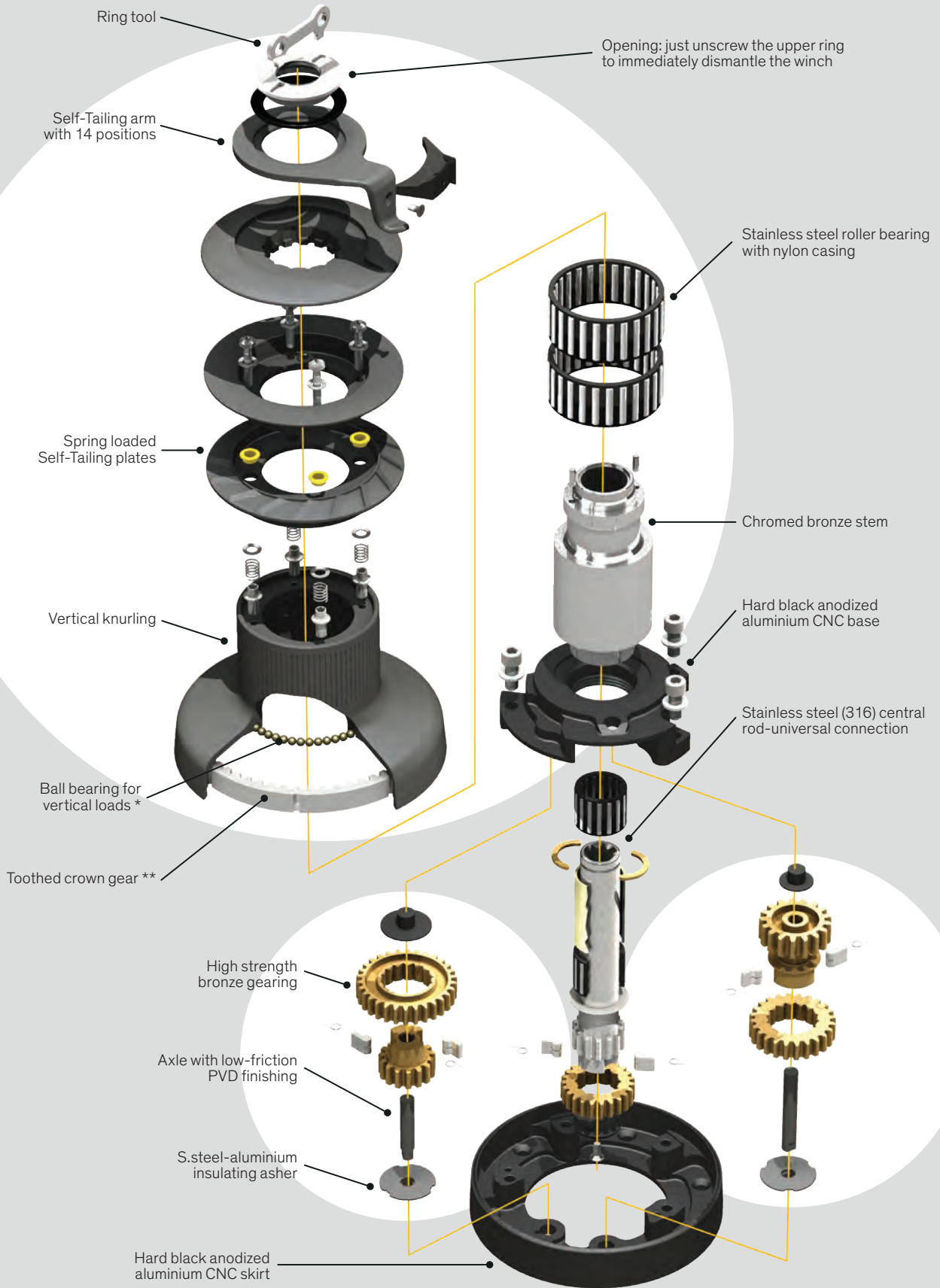

DRAWING REFERS TO WINCH MODELS FROM XT44 TO XT62

* Ball bearing for vertical load: from model XT48, on smaller models it is replaced by a plastic washer.

** The aluminium drum fitted with a high strength alloy crown gear is provided on the following XT models: sizes 62, 66, and 76, all racing winches from size 40 to size 76, all electrical and hydraulic versions up to size 62. The electric and hydraulic versions of models XT66, XT76 and XT80 are fitted with AISI316 S.Steel crown gear.

SELF-TAILING XT WINCHES



MOD. XT30AL

MOD. XT30CH

ONE REDUCED SPEED WINCH → XT16, XT30

The two smallest models (**XT16** and **XT30**) have a single reduced speed, giving a slow but powerful gear. The handle turns freely the other way. Both available in chrome (**CH**) or hard black alloy (**AL**).

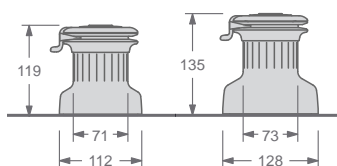

ONE SPEED WINCHES ↓

MODEL	XT16	XT30
POWER P1	14	28
RECOVERY S1 mm	115	58
Ø LINE mm	6 / 10	6 / 10
WEIGHT AL kg	2.4	2.7
WEIGHT CH kg	3.1	3.8
SCREWS N x Ø mm	5 x Ø6	5 x Ø6

TWO SPEED WINCHES: DIRECT, REDUCED → XT16.2, XT30.2

The addition of a direct speed to the above described models gives a faster recovery gear, which, combined with reduced weight and an automatic Self-Tailing for very thin lines, makes these models the best choice for racing.

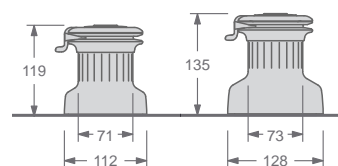

TWO SPEED WINCHES ↓

MODEL	XT16.2	XT30.2
POWER P1-P2	7.0 / 14	7.0 / 28
RECOVERY S1-S2 mm	229 / 115	229 / 58
Ø LINE mm	6 / 10	6 / 10
WEIGHT AL kg	2.6	2.9
WEIGHT CH kg	3.0	3.7
SCREWS N x Ø mm	5 x Ø6	5 x Ø6

TWO REDUCED SPEED WINCHES → XT40, XT44, XT48, XT52, XT62

Quick and powerful operation is obtainable with the first reduced speed, then with increasing load, simply wind in the opposite direction the second gear and maximum power is automatically selected.



MOD. XT52AL

MOD. XT52CH

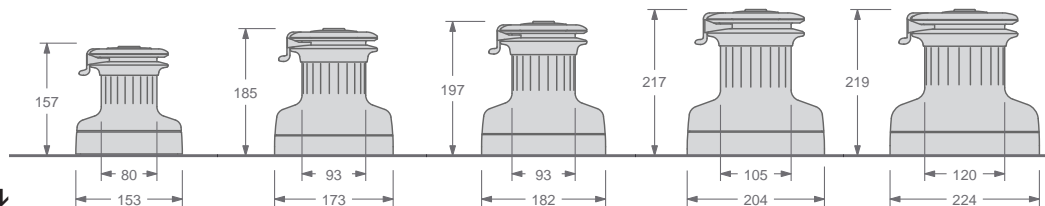

TWO SPEED WINCHES ↓

MODEL	XT40	XT44	XT48	XT52	XT62
POWER P1-P2	12.8 / 40.0	20.0 / 43.0	19.0 / 47.4	15.9 / 52.8	17.8 / 62.1
RECOVERY S1-S2 mm	125 / 40	80 / 38	84 / 34	100 / 30	89 / 26
Ø LINE mm	6 / 12	8 / 14	8 / 14	8 / 14	8 / 16
WEIGHT AL kg	4.4	6.2	6.9	9.2	10.9
WEIGHT CH kg	5.9	8.7	9.9	13.0	15.7
SCREWS N x Ø mm	5 x Ø8	6 x Ø8	6 x Ø8	6 x Ø8	6 x Ø8

All these models (from size 40) can be powered with electric or hydraulic motors (page 16-21).



TWO REDUCED SPEED WINCHES → XT66, XT76

Large drum winches for 15-18m boats. All the gears are fitted with roller bearings and the drum works on a very wide diameter roller-ball bearings.

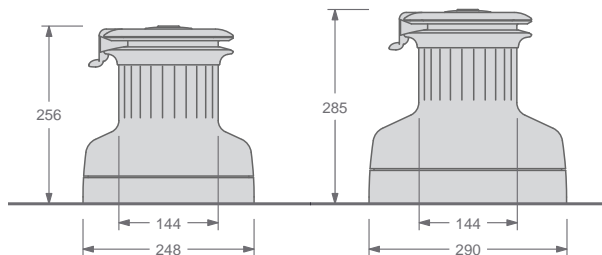

TWO SPEED WINCHES ↓

MODEL	XT66	XT76
POWER P1-P2	18.0 / 65.6	27.1 / 69.8
RECOVERY S1-S2 mm	89 / 24	59 / 23
Ø LINE mm	10 / 18	10 / 18
WEIGHT AL kg	16.3	18.5
WEIGHT CH kg	24.6	30.0
SCREWS N x Ø mm	6 x Ø10	6 x Ø10



THREE REDUCED SPEED WINCHES → XT62.3, XT66.3, XT76.3

The push-button on the base starts the first gear (the fastest); second and third gear are automatically selected simply by reversing the rotation of the handle.

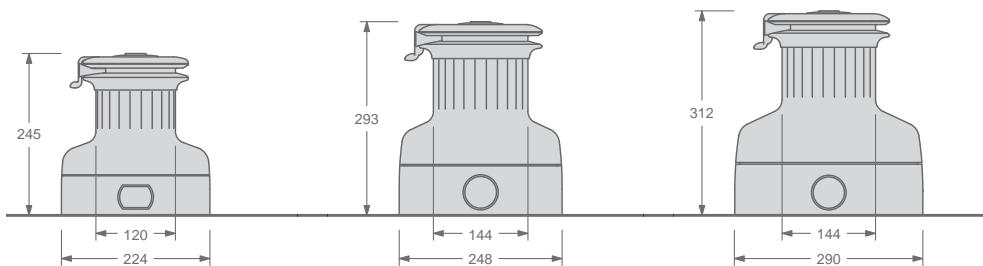

THREE SPEED WINCHES ↓

MODEL	XT62.3	XT66.3	XT76.3
POWER P1-P2-P3	6.7 / 17.6 / 61.1	10.7 / 20.8 / 65.3	10.7 / 27.1 / 69.8
RECOVERY S1-S2-S3 mm	239 / 91 / 26	151 / 77 / 24	151 / 59 / 23
Ø LINE mm	8 / 16	10 / 18	10 / 18
WEIGHT AL kg	12.8	18.6	22.8
WEIGHT CH kg	17.6	28.4	34.4
SCREWS N x Ø mm	6 x Ø8	6 x Ø10	6 x Ø10

P1-P2-P3: power with the first (fast), second (medium) and third (slow) gear.

S1-S2-S3: recovery speed, the length of line recovered with one turn of the handle in first, second and third gear.

ELECTRIC WINCHES



ELECTRIC WINCHES

All Antal winch models, from **MOD. XT40** to **MOD. XT76.3**, maxi **MOD. XT80.3** and **MOD. XT90.3** can be fitted with an electric motor. All electric winches are available with a chromed drum, now also black aluminium drums with a reinforced crown gear (high resistance alloy or A316 S.Steel) are available.

HORIZONTAL AND VERTICAL MOTORS: all the winches may be equipped with a horizontal motor and gearbox with a worm screw. The largest models may be supplied with a vertical motor which uses a high-efficiency hypocycloid speed reducer. Both solutions have been studied to ensure particularly compact dimensions and maximum silent operation.

MANUAL USE: simply insert the handle to disconnect the gearbox-motor unit.

GREATER SAFETY: accidental starting of the motor does not affect the winch, avoiding dangerous turning of the handle.

GREATER EFFICIENCY: the gearbox-motor unit does not turn in manual use, avoiding needless friction.

SPEED: Electric winches maintain two speeds both in manual use (inverting the direction of rotation of the handle) and in electric use (pressing one of the two control buttons).

It is of fundamental importance to be able to choose the most suitable speed for the manoeuvre that you want to perform; this allows fast recovery of the first part of the manoeuvre and more careful regulation in the final stage. In electric winches the speeds are higher than in manual use.

The recovery speed, indicated in the tables, is measured without a load; in the presence of the maximum load, a speed reduction of up to 30% must be considered.

All our electric winches are self tailing. For more information on these winches see pages 12-13.

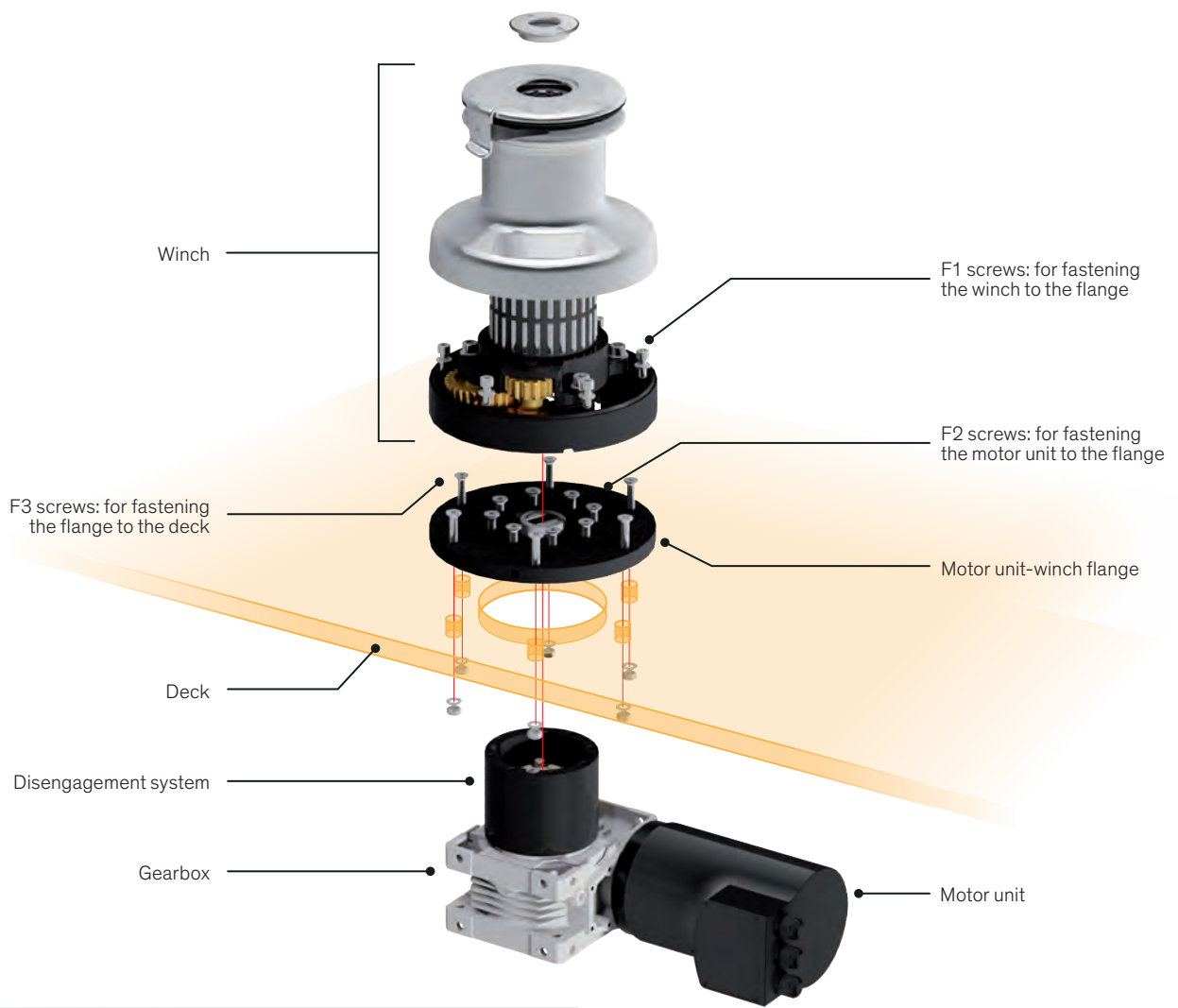

ELECTRIC WINCHES: FORCE, ABSORPTION AND SPEED

The force of the winch (pulling load), the current absorption (Amp) of the motor and the line recovery speed are related as shown in the diagrams obtained experimentally with load and recovery tests.

These diagrams are available for each model and clearly show the values of the maximum force with the fast and slow gears, the corresponding speed, and maximum electric absorption.



The documentation, including the force-absorption-speed diagrams, is available on request.

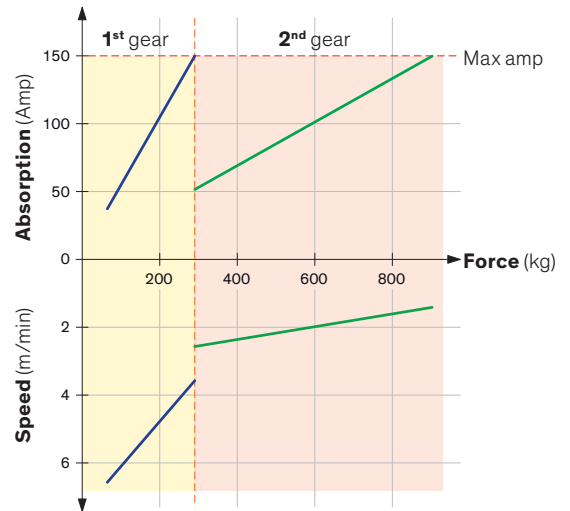

HORIZONTAL DRIVE - MOTOR 700W, 12/24/48V → XT40EH, XT44EH, XT48EH

The three **MOD. XT40, XT44** and **XT48** are powered with a 700 Watt motor, available in 12, 24 and 48 Volt versions. Two switches, one control box and one breaker complete the system.

MOD. XT40EH12CH

MOD. XT40EH12AL

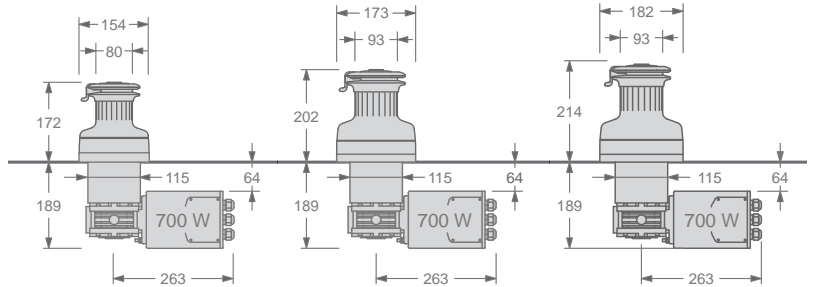

TWO SPEED WINCHES ↓

MODEL	XT40EH	XT44EH	XT48EH
LINE SPEED 1 m/min	12.0	11.0	11.0
LINE SPEED 2 m/min	4.5	4.0	4.0
WORKING LOAD kg	800	900	1000
GLOBAL WEIGHT AL kg	16.2	-	19.1
GLOBAL WEIGHT CH kg	17.7	20.7	22.1

XT44EH not available in AL version.

HORIZONTAL DRIVE - MOTOR 1000W, 12/24/48V → XT52EH, XT62EH, XT62.3EH

MOD. XT52, XT62 and **XT62.3** are powered with a 1000 Watt, 12, 24 and 48 Volt motor. Two switches, one control box and one breaker complete the system.

MOD. XT52EH12CH

MOD. XT52EH12AL

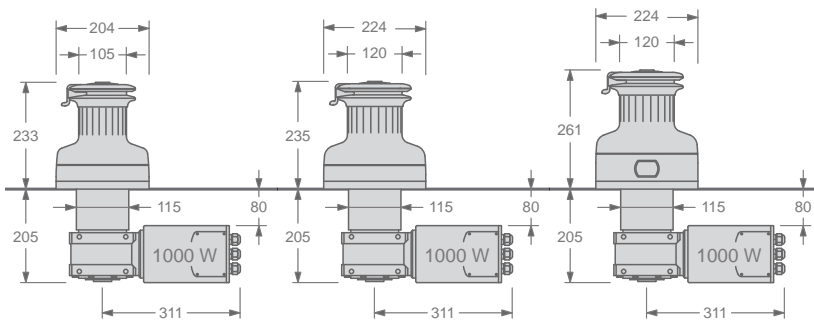

TWO OR THREE SPEED WINCHES ↓

MODEL	XT52EH	XT62EH	XT62.3EH
LINE SPEED 1 m/min	15.0	14.0	36.0
LINE SPEED 2 m/min	4.0	4.0	14.0
LINE SPEED 3 m/min	-	-	4.0
WORKING LOAD kg	1200	1500	1500
GLOBAL WEIGHT AL kg	26.3	28.3	30.2
GLOBAL WEIGHT CH kg	30.1	33.1	35.0

LINE SPEED – the recovery speed is calculated with the winch not under load; at maximum load the figure should be reduced by 30%.

MANUAL USE – the gearbox-motor unit is disengaged simply by inserting the handle.

CIRCUIT DIAGRAM – for the circuit diagram and accessories, such as switches, control boxes and breakers, see page 19. All our electric winches are Self-Tailing and are available in both versions: with chromed drum or with a reinforced black aluminium drum. For more information on these winches see pages 12-13.



MOD. XT76EH12AL

MOD. XT66EH12CH

HORIZONTAL DRIVE - MOTOR 1500W, 12/24/48V → XT66EH, XT76EH

MOD. XT66 and **XT76** are powered with a 1500 Watt, 12, 24 and 48 Volt motor. Two switches, one control box and one breaker complete the system.

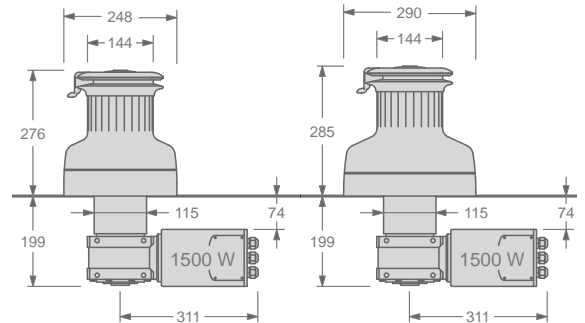

TWO SPEED WINCHES ↓

MODEL	XT66EH	XT76EH
LINE SPEED 1 m/min	12.0	9.0
LINE SPEED 2 m/min	3.5	3.0
WORKING LOAD kg	2500	3000
GLOBAL WEIGHT AL kg	31.9	35.9
GLOBAL WEIGHT CH kg	41.7	47.4

For the correct identification of the winch, add after the winch model in the tables the following number:

- **12, 24 or 48** for the respective versions;
- **AL** for black aluminium drum or **CH** for chromed drum.

E.g.: XT66EH12AL is an electric winch size 66 with horizontal drive 12V motor and with black aluminium drum.



MOD. XT76.3EH12AL

MOD. XT66.3EH12CH

HORIZONTAL DRIVE - MOTOR 1500/2000 W, 12/24/48V → XT66.3EH, XT76.3EH

These models maintain three speeds both in manual and in electric use; the push-button on the base starts the first gear (the fastest), second and third gear are automatically selected simply by reversing the rotation of the handle or pressing one of the two switches, one for the first and the third speed and one for the second.

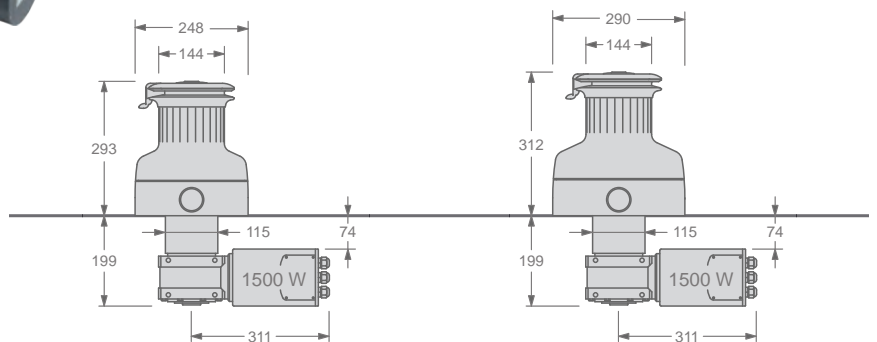

THREE SPEED WINCHES ↓

MODEL	XT66.3EH	XT76.3EH
LINE SPEED 1 m/min	22.0	21.0
LINE SPEED 2 m/min	12.0	9.0
LINE SPEED 3 m/min	3.5	3.0
WORKING LOAD kg	2500	3000
GLOBAL WEIGHT AL kg	35.7	40.3
GLOBAL WEIGHT CH kg	45.5	51.8



MOD. XT76EV12AL

MOD. XT76EV12CH

VERTICAL DRIVE - MOTOR 1500W, 12/24/48V → XT66EV, XT76EV

This motor-gearbox system is suitable for the largest Antal winches: **MOD. XT66** and **XT76**. A special hypocycloidal gearbox gives max efficiency.

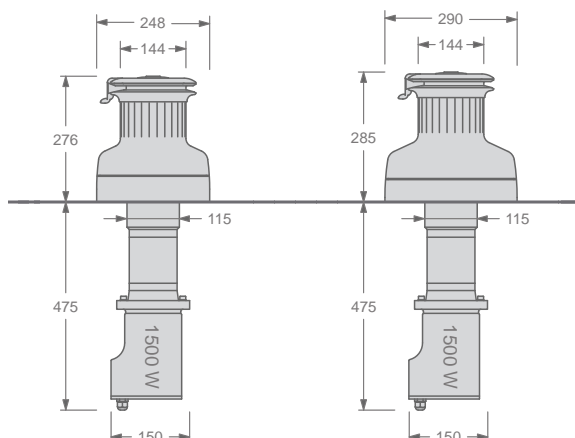

TWO SPEED WINCHES ↓

MODEL	XT66EV	XT76EV
LINE SPEED 1 m/min	12.0	9.0
LINE SPEED 2 m/min	3.5	3.0
WORKING LOAD kg	2500	3000
GLOBAL WEIGHT AL kg	35.6	39.1
GLOBAL WEIGHT CH kg	45.4	50.6

For the correct identification of the winch, add after the winch model in the tables the following numbers:

- **12, 24** or **48** for the respective versions;
- **AL** for black aluminium drum or **CH** for chromed drum.

E.g.: XT66EV12AL is an electric winch size 66 with vertical drive 12V motor and with black aluminium drum.

VERTICAL DRIVE - MOTOR 1500/2000W 12/24/48V → XT66.3EV, XT76.3EV

The **MOD. XT66.3**, **XT76.3** maintain three speeds both in manual and in electric use; the push-button on the base starts the first gear (the fastest), second and third gear are automatically selected simply by reversing the rotation of the handle or pressing one of the two switches, one for the first and the third speed and one for the second.

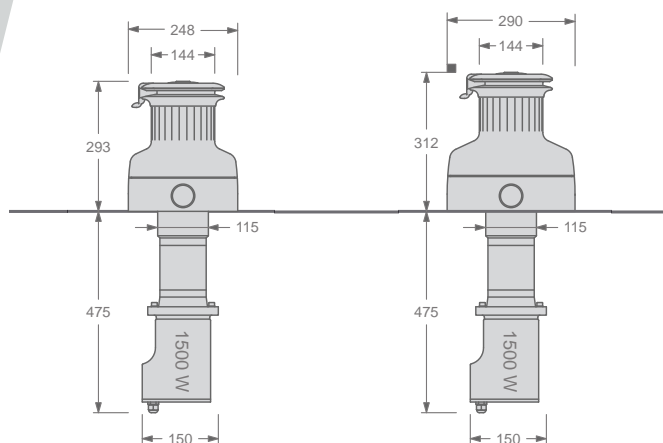

THREE SPEED WINCHES ↓

MODEL	XT66.3EV	XT76.3EV
LINE SPEED 1 m/min	22.0	21.0
LINE SPEED 2 m/min	12.0	9.0
LINE SPEED 3 m/min	3.5	3.0
WORKING LOAD kg	2500	3000
GLOBAL WEIGHT AL kg	38.6	42.1
GLOBAL WEIGHT CH kg	48.4	53.6

LINE SPEED – the recovery speed is calculated with the winch not under load; at maximum load the figure should be reduced by 30%.

MANUAL USE – the gearbox-motor unit is disengaged simply by inserting the handle.

CIRCUIT DIAGRAM – for the circuit diagram and accessories, such as switches, control boxes and breakers, see page 19. All our electric winches are Self-Tailing and are available in both versions: with chrome-plated drum or with a reinforced black aluminium drum.

For more information on these winches see pages 12-13.

ELECTRIC SYSTEM

AND ACCESSORIES



SWITCHES WITH S.STEEL COVER

→ MOD. 251.035SG – Grey button
 → MOD. 251.035SR – Red button
 Outer diameter – 78 mm



SWITCHES WITH PLASTIC COVER

→ MOD. 251.035QG – Grey button
 → MOD. 251.035QR – Red button
 Outer diameter – 78 mm



SWITCHES WITH ALUMINIUM COVER

→ MOD. 251.035AG – Grey button
 → MOD. 251.035AR – Red button
 Size 59x66 mm only



CONTROL BOX

Solenoids are contained in a water tight "control box"; they are available for 12, 24 and 48 Volt.



BREAKER

A breaker should be mounted to protect the motor against overload.

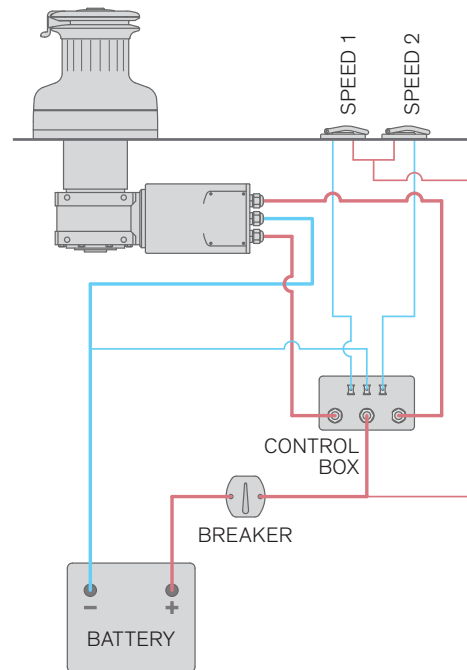

WINCH MODEL	MOTOR		BREAKER		CONTROL BOX MODEL
	WATT	VOLT	MODEL	AMP	
XT40 - XT44	700	12	A071	70	MZ2150PAC-12
		24	A041	40	MZ2150PAD-24
		48	A031	30	MZ2150PAE-48
XT48	700	12	A081	80	MZ2150PAC-12
		24	A041	40	MZ2150PAD-24
		48	A031	30	MZ2150PAE-48
XT52 - XT62	1000	12	A101	100	MZ2150PAC-12
		24	A051	50	MZ2150PAD-24
		48	A031	30	MZ2150PAE-48
XT66 - XT76	1500	12	A121	120	MZ2150PAC-12
		24	A071	70	MZ2150PAD-24
		48	A031	30	MZ2150PAE-48
XT76 - XT80.3	2000	24	A101	100	MZ2150PAC-12
		48	A031	30	MZ2150PAE-48
XT90.3	3000	24	A151	150	MZ2150PAD-24
		48	A031	30	MZ2150PAE-48

POWERED WINCHES LOAD CONTROL



MOD. WBC

To guarantee complete protection for powered winches, Antal offers the WBC, which keeps the winch from reaching its maximum working load. The winch is generally activated in the fastest gear.

When maximum absorption is reached, this gear is deactivated by the WBC and the slow gear must be used. This reduces the winch stress until maximum absorption (max load) is reached and the WBC also deactivates this

slow gear. Another safety device is the breaker that protects the motor from overheating due to too intensive use. However, it does not protect the winch from sudden excessive loads.

Therefore, both are necessary for complete protection. The WBC is suitable for two-speed Antal winches, with motors up to 2000W and maximum absorption of 250 amps.

HYDRAULIC WINCHES

HYDRAULIC SYSTEM

Hydraulic motors are available for Antal winches from **MOD. XT44** to **MOD. XT76.3**, as well as to maxi **MOD. XT80.3** and **MOD. XT90.3**. The pressure of the system varies from 100 to 120 bars for the larger winches.

Connections are to be carried out with 3/8" pipes. All hydraulic winches are available with a chromed drum, now also black aluminum drum with a reinforced crown gear (high resistance alloy or A316 S.Steel) is available. For **more information**, see **pages 12-13**. For manual use, the motor unit is released simply by inserting the handle.

LINE SPEED

Line speeds are calculated in absence of load conditions and considering the flow of the lower table. The effective speed will be evaluated according to the actual size of the hydraulic unit.

SWITCHES

Two switches with watertight protection must be installed for each winch. To identify the first and the second speed 2 colours are used: gray and red, S.Steel, plastic or aluminium version available.



MOD. XT62HDCH

MOD. XT62HDAL

For the correct identification of the winch, add after the winch model in the tables **AL** for black aluminium drum or **CH** for chromed drum.

E.g.: XT66HDAL is a hydraulic winch size 66 with black aluminium drum.

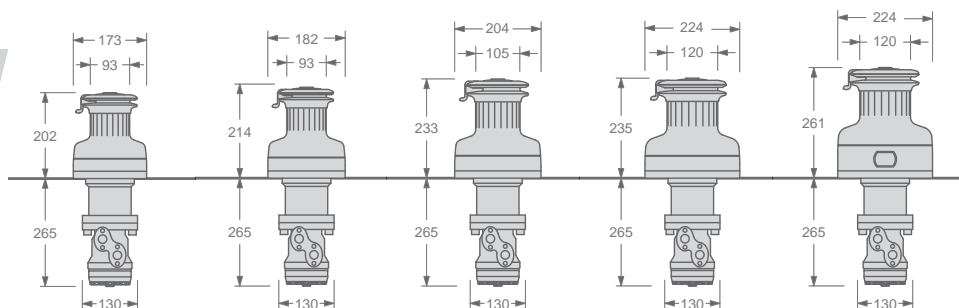

MODEL	XT44HD	XT48HD	XT52HD	XT62HD	XT62.3HD
LINE SPEED 1 m/min	12.0	12.5	16.0	13.0	36.9
LINE SPEED 2 m/min	5.5	5.0	4.6	4.0	13.0
LINE SPEED 3 m/min	-	-	-	-	4.0
WORKING LOAD kg	900	1000	1200	1400	1400
GLOBAL WEIGHT AL kg	17.2	18.2	20.4	22.2	24.1
GLOBAL WEIGHT CH kg	19.7	21.2	24.2	27.0	28.9
HYDRAULIC MOTOR ↓					
SIZE cc	50	50	50	50	50
PRESSURE bar	100	100	120	120	120
FLOW l/min	7.5	7.5	7.5	7.5	7.5

HYDRAULIC UNIT

These units are designed for the different requirements of each boat. The winch speed is proportional to the flow from the hydraulic unit, the load of the winch is proportional to the pressure. The hydraulic unit that must work a number of winches at the same time, must guarantee a flow equal to the sum of the flows required from each one. The flow and pressure levels given in the table for each winch must not be exceeded.



All these models are fitted with **Danfoss hydraulic motors series OMR** or equivalent.

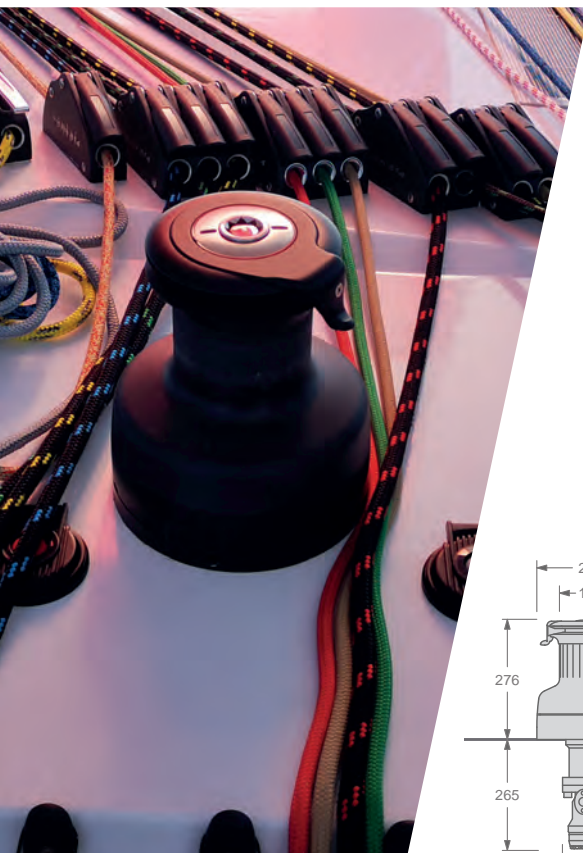
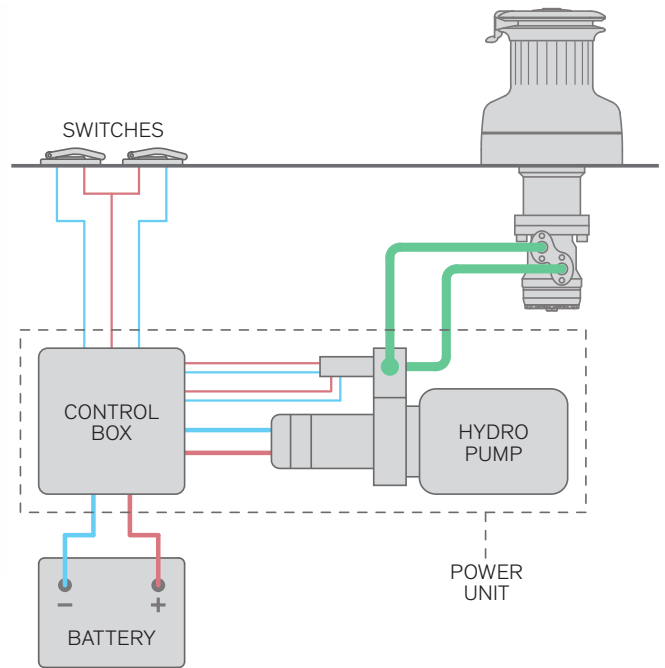

SWITCHES WITH S.STEEL COVER

→ MOD. 251.035SG – Grey button

→ MOD. 251.035SR – Red button

Outer diameter – 78 mm



SWITCHES WITH PLASTIC COVER

→ MOD. 251.035QG – Grey button

→ MOD. 251.035QR – Red button

Outer diameter – 78 mm



SWITCHES WITH ALUMINIUM COVER

→ MOD. 251.035AG – Grey button

→ MOD. 251.035AR – Red button

Size 59x66 mm only

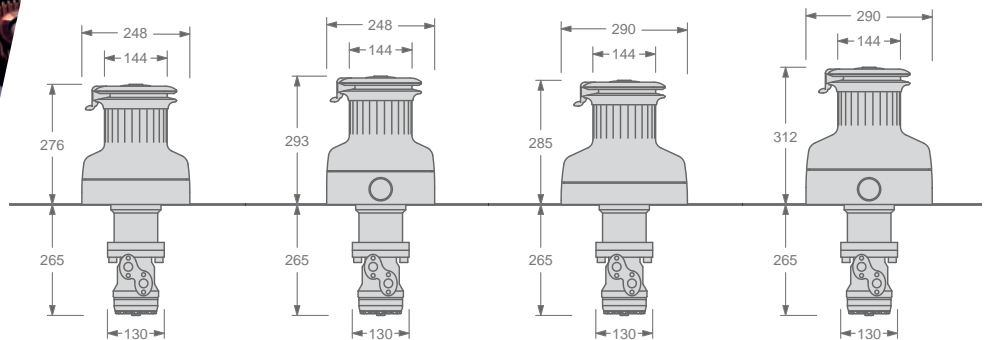

MODEL	XT66HD	XT66.3HD	XT76HD	XT76.3HD
LINE SPEED 1 m/min	13.0	23.0	9.0	23.0
LINE SPEED 2 m/min	3.6	12.0	3.5	9.0
LINE SPEED 3 m/min	-	3.6	-	3.5
WORKING LOAD kg	2600	2600	3000	3000
GLOBAL WEIGHT AL kg	24.5	28.3	28.4	32.7
GLOBAL WEIGHT CH kg	34.3	38.1	39.8	44.2
HYDRAULIC MOTOR ↓				
SIZE cc	80	80	100	100
PRESSURE bar	120	120	120	120
FLOW l/min	12	12	15	15

MAXI WINCHES

NEW



MOD. XT90.3AL

MOD. XT90.3CH

THREE REDUCED SPEED MAXI WINCHES → XT80.3, XT90.3

New Maxi winches for boats more than 20 m long are lighter and stronger than before. From **8000** kg to **11000** kg of SWL. From **102** kg to **82** kg of weight.

These models are almost always powered with electric motors, hydraulic motors or pedestal system. All the gears are fitted with roller bearings and the drum works on a very wide diameter roller-ball bearings. The push-button on the base starts the first gear (the fastest); second and third gear are automatically selected simply by reversing the rotation of the drive shaft.

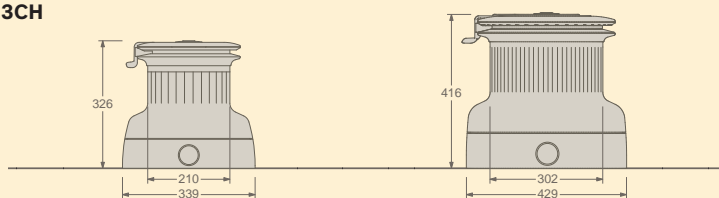

THREE SPEED WINCHES ↓

MODEL	XT80.3	XT90.3
POWER P1-P2-P3	11.0 / 30.0 / 81.4	13.7 / 35.8 / 90.2
RECOVERY S1-S2-S3 mm	147 / 53 / 20	116 / 45 / 18
Ø LINE mm	12 / 20	16 / 28
WEIGHT AL/CH kg	41.6 / 56.3	82 / 105
SCREWS N x Ø mm	8 x Ø10	8 x Ø12

HYDRAULIC MOTOR → XT80.3HD, XT90.3HD

Winches **MOD. XT80.3HD** & **MOD. XT90.3HD** can be powered by a hydraulic motor.

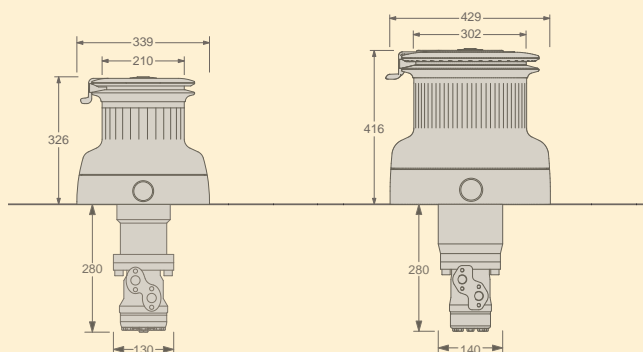

THREE SPEED WINCHES ↓

MODEL	XT80.3HD	XT90.3HD
LINE SPEED 1 m/min	22.0	18.0
LINE SPEED 2 m/min	8.0	7.0
LINE SPEED 3 m/min	3.0	2.5
WORKING LOAD kg	4000	11000
GLOBAL WEIGHT AL/CH kg	52.1 / 66.8	98 / 121

HYDRAULIC MOTOR ↓

SIZE cc	160	200
PRESSURE bar	120	180
FLOW l/min	24	30



Maxi Dolphin 75

HORIZONTAL DRIVE - 2000/3000W, 24/48V
→ XT80.3EH, XT90.3EH

MOD. XT80.3EH is fitted with a 2000W motor (24/48V), **MOD. XT90.3EH** is fitted with a 3000W motor (24/48V).

VERTICAL DRIVE - 2000/3000W, 24/48V
→ XT80.3EV, XT90.3EV

Vertical drive version is also available for **MOD. XT80.3EV** (2000W, 24/48V) and **MOD. XT90.3EV** (3000W, 24/48V) with a epicyclic gearbox.



MOD. XT80.3AL

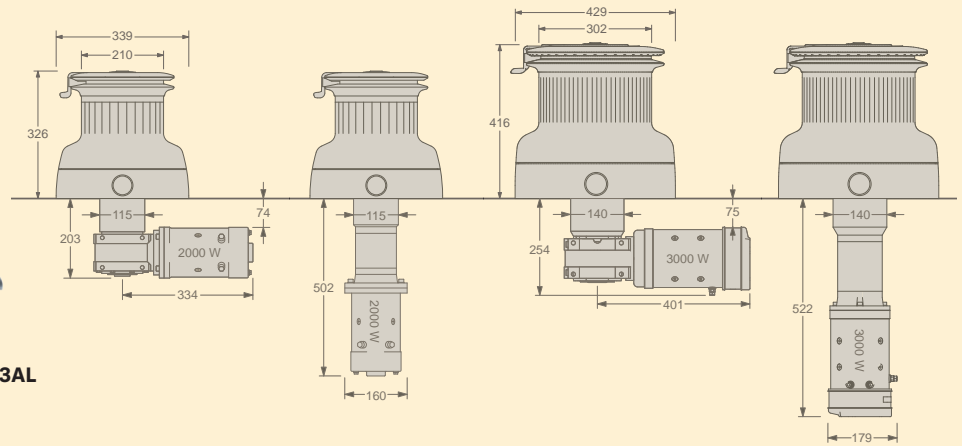

MODEL	XT80.3EH	XT80.3EV	XT90.3EH	XT90.3EV
LINE SPEED 1 m/min	24.0	24.0	18.0	18.0
LINE SPEED 2 m/min	9.0	9.0	7.0	7.0
LINE SPEED 3 m/min	3.0	3.0	2.5	2.5
WORKING LOAD kg	4000	4000	10000	11000
GLOBAL WEIGHT AL/CH kg	62.8 / 77.5	64.0 / 78.6	125 / 148	125 / 148
MOTOR W	2000	2000	3000	3000

CIRCUIT DIAGRAM – for the circuit diagram and accessories such as switches, control boxes and breakers see page 19.

XT RACE WINCHES

SELF-TAILING WINCHES: XT RACE SERIES

XT-R is the racing winch series obtained from the standard XT series, described above:

- Self-Tailing XT system;
- differentiated grip of the drum knurling;
- CNC base and skirt;
- fast opening screwed ring;
- axle with low friction PVD finishing.

And, in addition to reduce weight:

- aluminium stem;
- peek roller bearings for the drum and the main shaft;
- lightened gears and main shaft.



MOD. XT44R



The base, machined by the CNC process (produced with computer numeric control machines with no cast components), is lighter and stronger than normal castings.

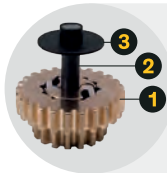

Antal alloy gears (1) mounted on low-friction and hard wearing PVD treated axles (2); corrosion-proof insulating gaskets (3).



To reduce weight, XT series winches are mounted on bearings with peek resin roller on an aluminium stem.

ONE REDUCED SPEED WINCHES ↓

MODEL	XT16R	XT30R
WEIGHT kg	1.95	2.35

TWO REDUCED SPEED WINCHES ↓

MODEL	XT16.2R	XT30.2R	XT40R	XT44R	XT48R	XT52R	XT62R	XT66R	XT76R
WEIGHT kg	2.0	2.2	3.6	4.7	5.3	7.1	8.5	13.6	16.2

For all others characteristics see tables on previous pages 12-13.

XT WINCHES

3-SPEED



MOD. XT53.3RD

MOD. XT62.3RD



1st speed push button on the top

1 DIRECT AND 2 REDUCED SPEED

→ XT53.3RD, XT62.3RD

MOD. XT53.3RD and **MOD. XT62.3RD** with one direct speed for a very fast recovery, plus two reduced speeds for medium and high loads are now available.

The push button on the top cover starts the first direct gear (the fastest), second and third reduced gears are automatically selected simply by reversing the rotation of the handle.

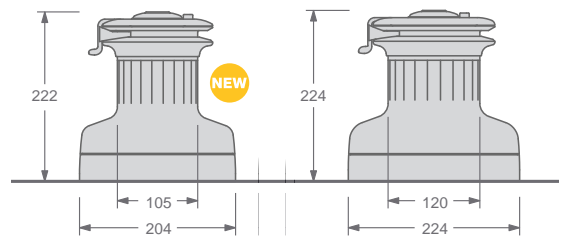

ONE AND TWO REDUCED SPEED WINCHES ↓

MODEL	XT53.3RD	XT62.3RD
POWER P1-P2-P3	4.8 / 15.9 / 52.8	4.2 / 17.8 / 62.1
RECOVERY S1-S2-S3 mm	333 / 100 / 30	377 / 89 / 26
Ø LINE mm	8 / 14	8 / 16
WEIGHT kg	6.5	9.2
SCREWS N x Ø mm	6 x Ø8	6 x Ø8

MOD. XT62.3R

MOD. XT76.3R



1st speed push button on the base

3 REDUCED SPEED WINCHES

→ XT62.3R, XT66.3R, XT76.3R

The push-button on the base starts the first gear (the fastest); second and third gear are automatically selected simply by reversing the rotation of the handle.

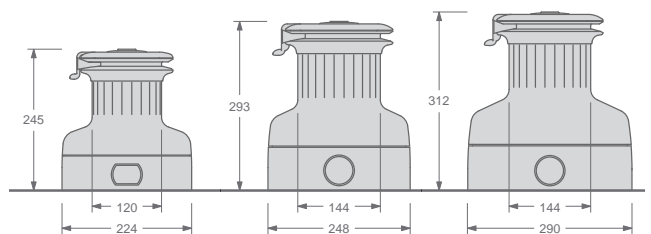

THREE REDUCED SPEED WINCHES ↓

MODEL	XT62.3R	XT66.3R	XT76.3R
POWER P1-P2-P3	6.6 / 17.8 / 62.1	10.7 / 20.8 / 65.3	10.7 / 27.1 / 69.8
RECOVERY S1-S2-S3 mm	241 / 89 / 26	151 / 77 / 24	151 / 59 / 23
Ø LINE mm	8 / 16	10 / 18	10 / 18
WEIGHT AL kg	10.4	16.2	20.3
SCREWS N x Ø mm	6 x Ø8	6 x Ø10	6 x Ø10

P1-P2-P3: power with the first (fast), second (medium) and third (slow) gear.

S1-S2-S3: recovery speed, the length of line recovered with one turn of the handle in first, second and third gear.

XT53.3RD

NEW



THE NEW ANTAL RACING WINCH

New racing winch **MOD. XT53.3RD**, extra light and designed for **Class40** ocean sailors. Now it is finally available for every type of boat. The winch is characterized by a direct speed for a quick recovery and a third more powerful speed for high loads.

Lightened structure and gears to reach the weight limit of just 6.50 kg, for the first time we tried the central shaft in extruded aluminium: 3 times lighter than the usual S.Steel version.

MODEL	XT53.3RD
POWER P1-P2-P3	4.8 / 15.9 / 52.8
RECOVERY S1-S2-S3* mm	333 / 100 / 30
WEIGHT kg	6.50
SCREWS N x Ø mm	6 x Ø8

* This is the length of the maneuver recovered with one turn of the handle.



JR66.3 & JR84.3

NEW

CARBON FIBER
The JR line is available in carbon fiber.

FOR THE MOST DEMANDING PERFORMANCES

The winches from the new **JR line (MOD. JR66.3 and MOD. JR84.3)** are designed for the most demanding performances, available in **aluminium** and **carbon fiber versions**. The new JR winch range is inspired by the world of modern racing yachts where lightness, power, and speed are the guiding principles in the design of every component.

Our Technical Office has studied all the solutions to achieve the lightest winch on the market for each size and power. To achieve this result, **technological innovations** have been introduced both in the components and in the construction methods.



MODEL	JR66.3	JR84.3
POWER P1-P2-P3	3.5 / 22.0 / 66.0	2.0 / 12.5 / 84.0
RECOVERY S1-S2-S3* mm	452 / 74 / 24	785 / 128 / 19
WEIGHT AL kg	11.3	24.0
DRUM / BASE / HEIGHT mm	144 / 248 / 208	250 / 336 / 238
SCREWS N x Ø mm	6 x Ø10	6 x Ø10



PEDESTALS FOR WINCHES

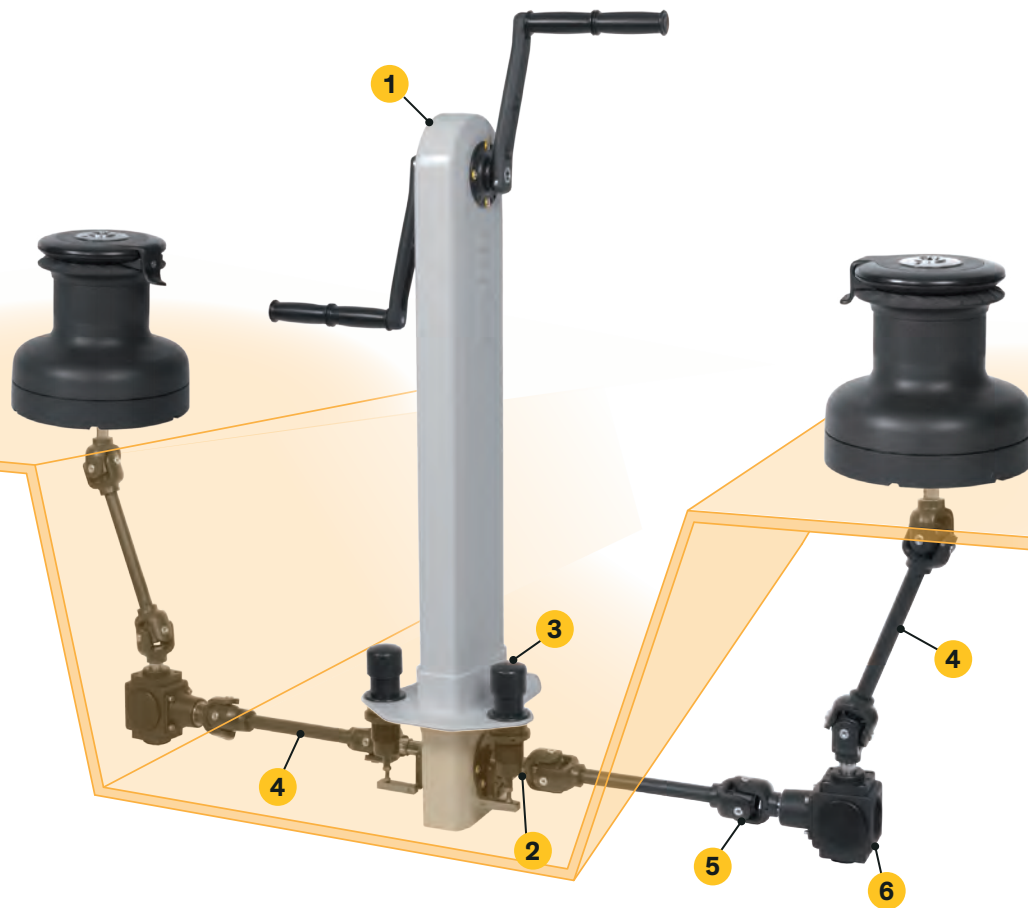

RACE SYSTEM

The Antal pedestal in carbon fibre relies on a belt drive that guarantees a light system. Thanks to the push buttons (3), the person operating the handles can control one, two or more winches independently. Note that the push button does not engage the third speed: this can be still engaged by pushing the

winch knob at the base of the winch. The system also comprises drive shafts (4), in customised lengths on request, and gearboxes (6). Moreover, the cardan joints (5) allow the drive shafts to be angled even to a large degree, thus enabling them to adapt to any hull design.





MOD. C001

9.8 kg

CARBON FIBRE PEDESTAL, with belt drive on toothed sheaves that are mounted on steel roller bearings and Teflon balls.



MOD. C002

1.2 kg

DRIVE-BOX, which transmits the drive from the pedestal to the axle of the single winch.



MOD. C003

0.7 kg

PUSH-BUTTON, which turns the drive-box on and off, and permits to choose which winch to work on.



MOD. C004/xx

1.2 kg/m

ALUMINIUM DRIVE SHAFT with black anodized ribbed end. Customised length on request.



MOD. C005

0.5 kg

ALUMINIUM UNIVERSAL JOINT with HR steel axles, mounted on both ends of the drive shaft, which enables to incline the shaft by large degrees.

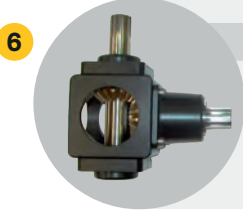

MOD. C006

2.76 kg

GEAR BOX in right and left hand version, bronze gears on ball/roller bearings, HR steel axles and black anodized aluminium box.



CLASSIC PEDESTAL, MECHANICAL DRIVE

This system is entirely run by a **mechanical drive**: drive shafts and bevel gears.

The classic system includes the same components as the race system but with the following differences: the pedestal is hard black anodized aluminium made, with shaft and bevel transmission.

The classic solution is installed entirely above deck with no components under deck.

The shaft from the pedestal to the winch is protected by **S.Steel casing**.

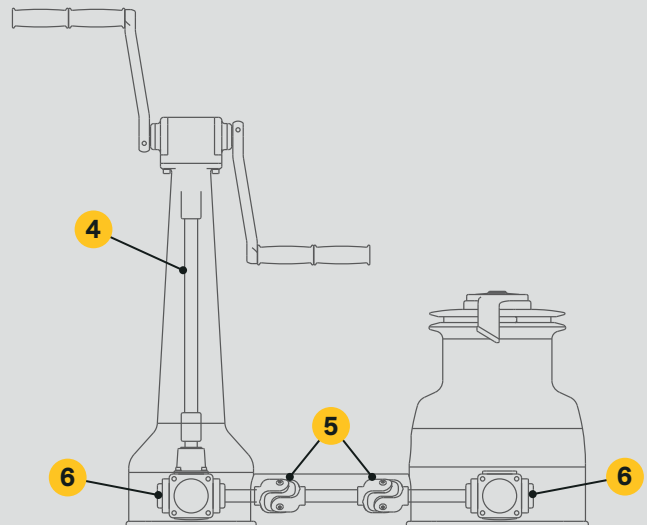

CLASSIC WINCHES



CLASSIC SERIES WINCHES

Classic series winches (**CHC**) are supplied not only with a chromed drum, ST disks and ST arm, as the chrome series models (**CH**) described on pages 12-13, but also with a chromed lower skirt, thus being completely chromed.

The chrome-plating is carried out with great care to guarantee maximum durability. First the unit are highly polished, then thickly nickel-plated and finally finished in chrome.

All classic winches are **available on request version W (without ST)**.

POLISHED BRONZE

On request, Antal classic winches can be supplied (with drum, ST disks, ST arm and skirt) made of polished natural bronze finish (add **BNC** after the winch model).



MOD. 2031WBN

Natural bronze winch handle with wooden grip.



LINE DRIVER

Amel 50 – Ph. J.S. Evrard



TRAVELLER CONTROL SYSTEM

The control system is connected to a traveller on a closed circuit and ensures efficient control and a clean layout.

The system uses a self tailing pulley which operates in both direction with a textile "gripping" system that is efficient even if the circuit is not under strain and causes no wear in the rope.

A clutch pin sets the direction in which the traveller moves, or allows for it to be locked in the required position.

The power ratio obtainable with a normal (250 mm) handle is 8 to 1, which is much better than a tackle can offer; moreover, this system has a very limited size and weight.

MATERIALS – it is made of hard black anodized aluminium, central rod and ball bearing of AISI316 stainless steel. A 10 mm line is strongly recommended.

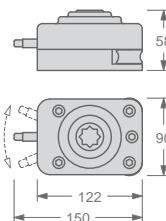

MODEL	240.010
LINE Ø mm	10
POWER	8:1
WEIGHT kg	1.40
SCREWS N x Ø mm	3 x Ø8

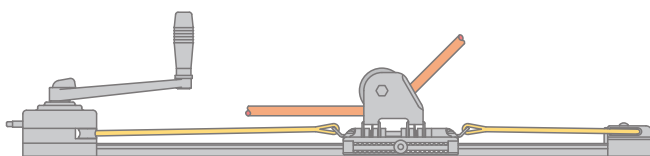

Genoa car

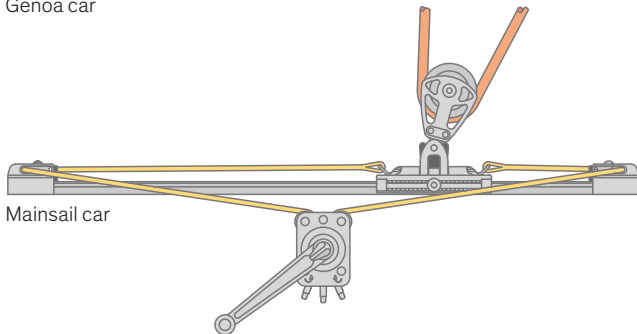

Mainsail car



POWERED LINE DRIVER

POWERED LINE DRIVER

This is a solution done for the control of the main car with a simple "Self-Tailing" sheave on the deck, a motor and gearbox under the deck.

Three sizes available with 700, 1000 and 1500 W motors in **12**, **24** and **48** Volt version. The largest model is also available in the hydraulic version. This model offers a maximum load on the circuit of 900 kg (100 bar pressure) with a line speed according to the flow rate of the hydraulic system.



MOD. LD1000



Nacra 69, A. De Beaufort & G. Verdier – Ph. Maxime Horlaville

For the correct identification of the line-driver, add after the LD model in the tables **/12**, **/24** or **/48** for the respective versions.

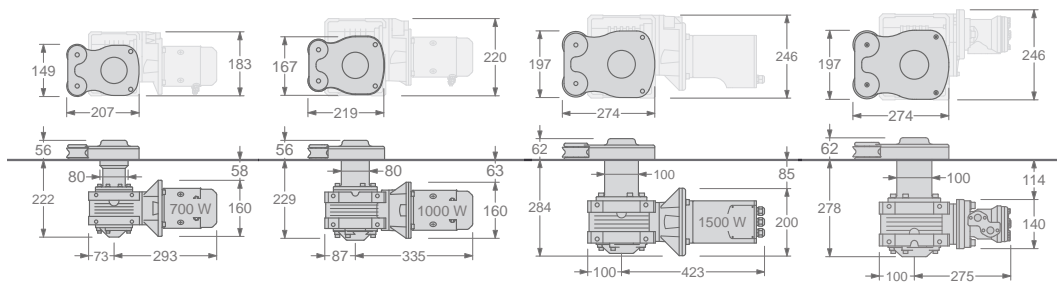

MODEL	LD700	LD1000	LD1500	LD1500HD
MOTOR	Electric 700 W	Electric 1000 W	Electric 1500 W	Hydraulic 25 cc
LINE Ø mm	10 / 12	12 / 14	12 / 14	12 / 14
WEIGHT kg	15	20	22	22
SCREWS N x Ø mm	4 x Ø8	4 x Ø8	4 x Ø8	4 x Ø8
2:1 CAR CONTROL ↓				
MAIN CAR SIZE mm	47 x 230	47 x 330	47 x 430	47 x 430
MAIN CAR MODEL	614.219	614.229	614.239	614.239
WORKING LOAD kg	800	1260	1600	1800 *
CAR SPEED m/sec	0.08	0.10	0.12	0.10 **

Car speed and working load are based on a **2:1 car control** as described in the figure on the following page. For a direct 1:1 control, the speed is doubled and the load is halved. Under the maximum load, the speed is reduced by up to even 30%. For cars, see page 146.

* Pressure 100 Bar
** Flow 25 l/min

SWITCHES

CONTROL-BOX

BREAKER



CAR END STOP CONTROL

MOD. 6320 - 12/24V, MOD. 6320/48 - 48V

To avoid overloads due to wrong operations, a **car end stop** control is available on request: two proximity switches - connected to a control unit - stop the car automatically at the track end.

A S.Steel plate must be attached to the bottom of the car to allow activation of the proximity switches.



END STOP CONTROL UNIT



PROXIMITY SWITCHES

The **speed** is calculated with the car not under load; at maximum load the figure should be reduced by 30%.

Two **switches**, for the left and the right car movement, a control-box and a safe circuit breaker to complete the electrical system (on page 19).

- Red line | Electric diagram
- Blue line | Electric diagram
- Green line: end stop control system (optional)

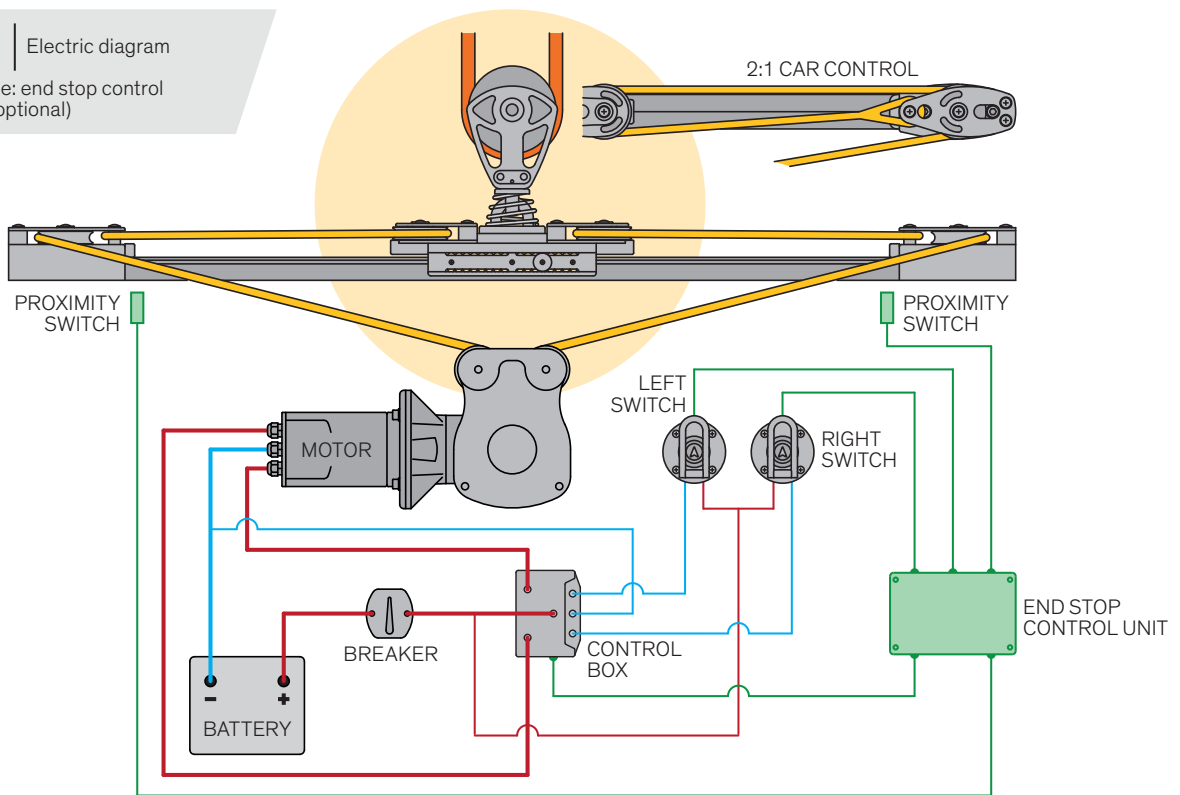

FORCE, ABSORPTION AND SPEED

Force, absorption and speed. The **force** (pulling load) of the Line Driver, the current **absorption** (Amp) of the motor and the **line speed** are related as shown in the diagrams obtained experimentally with load and recovery tests.

For each model, these diagrams clearly show the values of the maximum force, the corresponding speed and the current absorption.



The documentation, including the force-absorption-speed diagrams, is available on request.

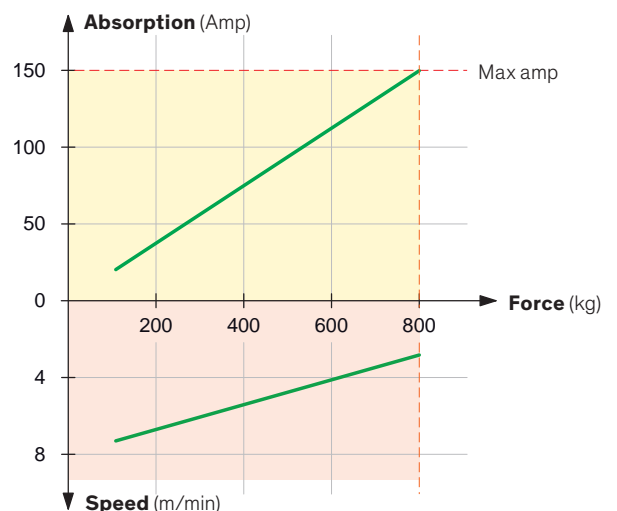

WINCH HANDLES

WINCH HANDLES

In addition to the extremely light black aluminium handles in two sizes: 200 mm (8 inches) and 250 mm (10 inches), there is also the classic chromed or natural polished bronze solution, always 250 mm long. Three different grips are available: the single, the double and the new "ball-grip".

The handle arm made of forged aluminium with lightening holes is extremely light and resists the heaviest torsion.

The grip is covered with rubber to give a firm hold and runs on two ball bearings to increase its efficiency (single-grip and ball-grip only). All the models are available with or without the lock system which automatically locks the handle on the winch.

To refer to the "no-lock" version add **NL** to the code.

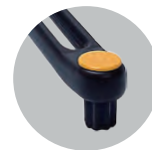

↓ ALUMINIUM (L – 200 mm)

MODEL	2011	2012	2014
HAND GRIP	single	ball-grip	mini ball-grip
WEIGHT kg	0.38	0.48	0.36

↓ ALUMINIUM (L – 250 mm)

MODEL	2021	2022	2023
HAND GRIP	single	ball-grip	double
WEIGHT kg	0.43	0.53	0.62



↓ CHROMED (L – 250 mm)

MODEL	2031	2032	2033
HAND GRIP	single	ball-grip	double
WEIGHT kg	0.87	0.97	1.07

↓ CUSTOM SOLUTIONS

Custom solutions are available on request: wooden grips (**MOD. W**), natural bronze (**MOD. BN**), special engravings on request.



CUSTOM

SPEEDYLOCK

THE SPEEDY WAY TO LOCK-UNLOCK
THE WINCH HANDLE

SPEEDYLOCK

Speedylock is the new Antal winch handle, available with the 250 mm lever with single, ball and double grip. Hard black anodized forged aluminium lever, rubber grip on two ball bearings (on single-grip and ball-grip version).

↓ ALUMINIUM (L – 250 mm)

MODEL	2121	2122	2123
HAND GRIP	single	ball-grip	double
WEIGHT kg	0.43	0.53	0.62

SPEEDYLOCK (SHORT)

Speedylock is also available in the 200 mm version with a single, ball-grip, or mini-ball grip.

Hot-forged aluminum profile, rubber handle with two ball bearings.

↓ ALUMINIUM (L – 200 mm)

MODEL	2111	2112	2114
HAND GRIP	single	ball-grip	mini ball-grip
WEIGHT kg	0.43	0.54	0.41

NEW



Grand Soleil Yachts; GS34 – Ph. P. Lanfrancotti & F. Taccola





CLUTCHES



Cam 611 40



V-Cam 814 42



V-Cam R814 44



Plus & Maxi 46



QR (Quick Release) 48



DV Jammer 50



V-Grip 52



Organizers 53



Swivelling cam-cleat 54



Stopper deck-blocks 55

CLUTCH SELECTION GUIDE

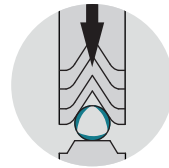

1
Pressure on
3 sides



2
Load
distribution



3
Line retrieval
with closed lever



4
Emergency
opening



MODELS

LINE DIAMETER ↓	CAM 611	CAM 611 / V*		V-GRIP*			V-CAM R814* / 814*			V-GRIP PLUS*		
		6	8	10	12	14	10	12	14	12	14	16
Ø = 6 mm	250	400										
Ø = 8 mm	380		600	600			600					
Ø = 10 mm	500			700	700		850	850		1050		
Ø = 12 mm				1000	1000	1000		1200	1200	1400	1400	
Ø = 14 mm					1300	1300			1500		1700	1700
Ø = 16 mm						1600						2100

CLUTCH MAX LOAD kg

* These models are fitted with the **V-Grip system** that is internationally patented.

V-GRIP SYSTEM CLUTCHES

The V-Grip is an Antal patented system for rope locking. It works with a pressure exerted on 3 sides of the line with a higher friction and, consequently, with a lower pressure, in order not to damage manoeuvres. All Antal clutches, except the Cam 611, are fitted with the V-Grip system.

The V-Grip system has the following characteristics:

- 1 Pressure on three sides.** Unlike the usual flat cam, V-Grip is fitted with a V-shaped cam that improves the holding strength without damaging the line cover.
- 2 Load distribution.** The curved base-V-Cam pair increases the bearing surface, preventing the load from being concentrated at a critical point.
- 3 Line retrieval with closed lever.** Line retrieval can be achieved with the lever closed. The line stops automatically in the new position with no slippage.
- 4 Emergency opening.** The line can be released under load without the use of a winch because the Antal mechanism guarantees easy opening even under heavy conditions.

Ocean Tec 50

CLUTCH RANGE

A complete range with 7 different models for lines from 6 to 22 mm. All Antal models, except the Maxi, the QR and the DV-Jammer, are available in single, double, triple and quadruple versions. The Cam 611 and Cam 814 are also available in a silver version with the new ergonomic aluminium lever.

CLUTCH SELECTION

Max loads of the lower table for each model and for different line diameters have been obtained from extensive tests. Tests reveal best results on Dyneema™ with composite Kevlar/Polyester covers, while traditional pure-Polyester covers over a Dyneema™ core prove to have poor resistance. Also "all-Polyester" core/cover versions give excellent results.

MODELS



LINE DIAMETER ↓	V-GRIP MAXI*					QR			DV JAMMERS					
	14	16	18	20	22	10	12	14	8	10	12	14	16	18
∅ = 8 mm									1500					
∅ = 10 mm						1600				2000				
∅ = 12 mm	1400						2200				3000			
∅ = 14 mm	1700	1700						3000				4000		
∅ = 16 mm		2100	2100										5000	
∅ = 18 mm			2600	2600										6000
∅ = 20 mm				3000	3000									
∅ = 22 mm					3400									

CAM 611

SERIES



Cam 611 Silver – MOD. 543.110
V-Cam 611 Silver – MOD. 540.110

Cam 611 – MOD. 513.110
V-Cam 611 – MOD. 500.110

V-GRIP SYSTEM CLUTCHES



Cam 611 for line 6 to 10 mm is available in single, double and triple, as well as horizontal. Cam 611 has a box structure in UV-resistant resin with steel reinforcements, an extruded aluminium base, wear-resistant bronze cam mechanism, and stainless steel aligning bushing.

The clutch can be completely dismantled for simple maintenance. Line retrieval can be achieved with the lever closed, and the cam mechanism guarantees easy opening even under heavy load.

V-CAM 611 WITH V-CAM



V-Cam 611 is a new model with a V-Cam, for lines from 6 to 8 mm.

This new version supports much higher loads: 400 kg on the 6 mm line and 600 kg on the 8 mm. All the features are the same of Cam 611, as shown in the following table.

V-CAM 611 SILVER

Both Cam 611 and V-Cam 611 clutches are now available in the silver series: with a new ergonomic, polished and silver anodized aluminium lever. All the characteristics remain the same as shown in the following table.

Heinrich Werft, Yunikon



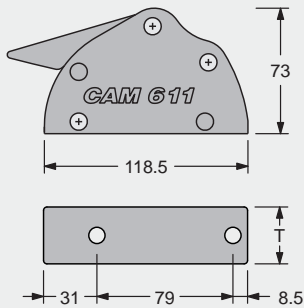

Single





Double



Triple



Horizontal

CAM 611	CAM 611 SILVER	WITH FLAT CAM				
MODEL	MODEL	Ø LINE mm	TYPE	T mm	WEIGHT kg	SCREWS N x Ø mm
513.110	543.110	6 / 10	single	33	0.37	2 x Ø6
513.120	543.120		double	62	0.74	4 x Ø6
513.130	543.130		triple	91	1.10	6 x Ø6
513.210	543.210		horizontal	33	0.51	2 x Ø6 + 1 x Ø5
						
V-CAM 611	V-CAM 611 SILVER	WITH V-CAM				
MODEL	MODEL	Ø LINE mm	TYPE	T mm	WEIGHT kg	SCREWS N x Ø mm
500.110	540.110	6	single	33	0.37	2 x Ø6
500.120	540.120		double	62	0.74	4 x Ø6
500.130	540.130		triple	91	1.10	6 x Ø6
500.210	540.210		horizontal	33	0.51	2 x Ø6 + 1 x Ø5
501.110	541.110	8	single	33	0.37	2 x Ø6
501.120	541.120		double	62	0.74	4 x Ø6
501.130	541.130		triple	91	1.10	6 x Ø6
501.210	541.210		horizontal	33	0.51	2 x Ø6 + 1 x Ø5

DOUBLE SHEAVE ORGANIZER



This solution has been designed for the new double and triple Cam 611: mounted at the back of the clutch battery guiding the line towards the winch.

For more information see page 53.

STICKERS FOR CAM 611 AND CAM 814



A set of 69 stickers is provided for an easy indication of manoeuvres; colours: red, green and black.

MODEL	VERSION
514E	English
514F	French
514I	Italian



V-CAM 814

SERIES



V-Cam 814 Silver – MOD. 549.111

V-Cam 814 – MOD. 509.111

V-CAM 814

Three models for 8-10 mm, 10-12 mm and 12-14 mm lines; available in single, double, triple and quadruple. V-Cam 814 has a box-structure in UV-resistant resin with S.Steel reinforcements, aluminium base, V-Cam and aligning bushing in AISI316.

It can be completely dismantled for simple maintenance and repairing. Line retrieval can be achieved with the lever closed.

This model is fitted with a large V shaped cam that offers higher holding strength than model V-Grip (page 52) and a new mechanism that guarantees easy opening even under heavy load.

V-CAM 814 SILVER

V-Cam 814 clutches are now available in silver series: with a new ergonomic, polished and silver anodized aluminium lever.

All the characteristics remain the same as shown in the following table.



V-CAM 814

V-CAM 814 SILVER

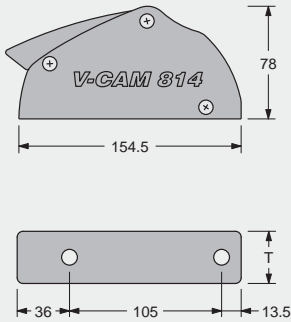

MODEL	MODEL	Ø LINE mm	TYPE	T mm	WEIGHT kg	SCREWS N x Ø mm
509.111	549.111	8/10	single	36	0.60	2 x Ø6
509.121	549.121		double	65	1.10	4 x Ø6
509.131	549.131		triple	94	1.60	6 x Ø6
509.141	549.141		quadruple	123	2.10	8 x Ø6
509.111H	549.111H		horizontal	36	0.72	2 x Ø8 + 1 x Ø5
509.112	549.112	10/12	single	36	0.60	2 x Ø8
509.122	549.122		double	65	1.10	4 x Ø8
509.132	549.132		triple	94	1.60	6 x Ø8
509.142	549.142		quadruple	123	2.10	6 x Ø8
509.112H	549.112H		horizontal	36	0.72	2 x Ø8 + 1 x Ø5
509.113	549.113	12/14	single	36	0.60	2 x Ø8
509.123	549.123		double	65	1.10	4 x Ø8
509.133	549.133		triple	94	1.60	6 x Ø8
509.143	549.143		quadruple	123	2.10	6 x Ø8
509.113H	549.113H		horizontal	36	0.72	2 x Ø8 + 1 x Ø5



Single



Double



Triple



Quadruple



Horizontal

V-CAM 814 CLUTCH ORGANIZER

This solution allows manoeuvres to be guided from the clutches to the winch. For more information see page 53.



MODEL	N° SHEAVES
513.032	3
514.032	4
515.032	5
516.032	6
517.032	7

MULTI RING ORGANIZER

The low friction Multi Ring Organizer without sheaves is a very light and small-sized solution that fits lines up to 12 mm. For more information see page 191.



MODEL	N° HOLES
R3.14	3
R4.14	4
R5.14	5
R6.14	6
R7.14	7

V-CAM R814

NEW

V-CAM R814

The new series of Antal clutches for loads up to 1500 kg. It is fitted with a large V-Shaped cam: the V-Grip Antal system.

Three sizes for 8-10, 10-12 and 12-14 mm lines in five versions: single, double, triple, quadruple and side mounting. Quintuple batteries or more on request.

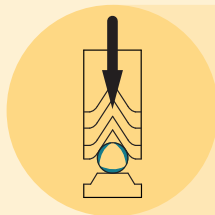

V-GRIP

The V-Grip is an Antal patented system for rope locking. It works with a pressure exerted on 3 sides of the line with a higher friction and, consequently, with a lower pressure, in order not to damage the manoeuvres.

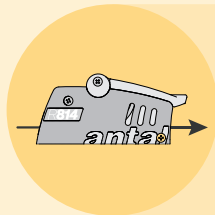

LINE RETRIEVAL

Line retrieval can be achieved with the lever closed. The line stops automatically in the new position with no slippage.

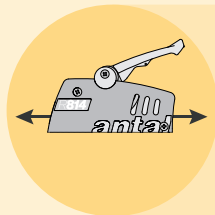

OPENING

The line can be released under load, the Antal mechanism guarantees easy opening even under heavy conditions.

The new R814 is the improved version of the previous 814 described on page 42 and offers the following features:

- 1 S.Steel plates.** Line entry is protected by S.Steel guides for the best smoothness.
- 2 Cleaning slots.** Spray fresh water through the side openings for cleaning.
- 3 Exit ring.** The exit ring is integrated in the base for the maximum resistance to the side loads.
- 4 Maneuvers label.** Set of different labels available in English, French and Italian, respectively **MOD. 513E, 513F, 513I**. Each set includes 23 labels in 3 colors: black, green (right side) and red (left side) for a total of 69 labels.
- 5 Upward line direction.** A 3° inclined base to better direct the maneuver to the winch.

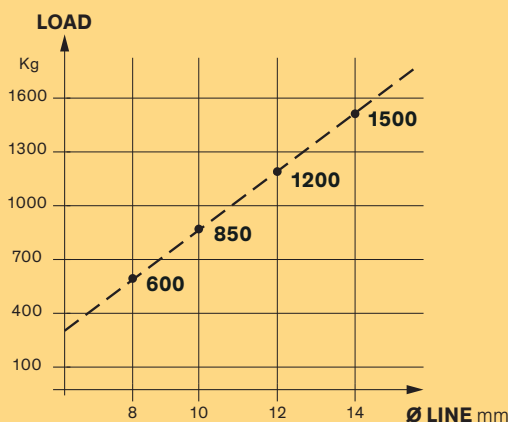

LOAD DIAGRAM

Max load of the diagram have been obtained from **extensive tests** for different line diameters.

Higher load values may damage the line cover, not the clutches. Tests reveal **best result on Dyneema™** lines with composite kevlar/polyester cover while traditional pure polyester covers over Dyneema™ cores prove to have poor resistance. Better results for polyester cover with polyester core.

In case of line slippage it may be useful to consider a smaller version. For example, if a 10 mm line slips on a 10-12 model the solution is to use a 8-10 clutch.

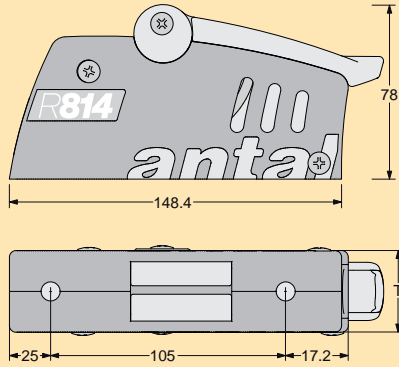

MODEL	Ø LINE mm	TYPE	T mm	WEIGHT kg	SCREWS N x Ø mm
512.111	8/10	single	36.5	0.56	2 x Ø8
512.121		double	65.5	1.05	4 x Ø8
512.131		triple	94.5	1.50	6 x Ø8
512.141		quadruple	123.5	2.00	8 x Ø8
512.111H*		horizontal	-	0.70	2 x Ø8 + 1 x Ø5
512.112	10/12	single	36.5	0.56	2 x Ø8
512.122		double	65.5	1.05	4 x Ø8
512.132		triple	94.5	1.50	6 x Ø8
512.142		quadruple	123.5	2.00	8 x Ø8
512.112H*		horizontal	-	0.70	2 x Ø8 + 1 x Ø5
512.113	12/14	single	36.5	0.56	2 x Ø8
512.123		double	65.5	1.05	4 x Ø8
512.133		triple	94.5	1.50	6 x Ø8
512.143		quadruple	123.5	2.00	8 x Ø8
512.113H*		horizontal	-	0.70	2 x Ø8 + 1 x Ø5



The clutch is equipped with entry and exit guides to allow small deviation of the maneuver.

For larger deviations the use of a **Multi Sheaves** or **Multi Ring Organizer** is recommended.

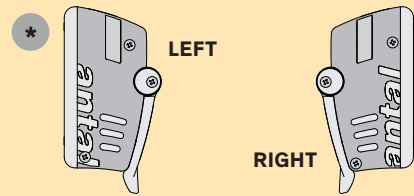

Left and right versions of horizontal clutches are available, just add **L** (left) or **R** (right) to the model code when ordering.

V-CAM R814 CLUTCH ORGANIZER

This solution allows manoeuvres to be guided from the clutches to the winch. For more information see page 53.



MODEL	N° SHEAVES
513.032	3
514.032	4
515.032	5
516.032	6
517.032	7

MULTI RING ORGANIZER

The low friction Multi Ring Organizer without sheaves is a very light and small-sized solution that fits lines up to 12 mm. For more information see page 191.



MODEL	N° HOLES
R3.14	3
R4.14	4
R5.14	5
R6.14	6
R7.14	7

PLUS & MAXI

SERIES



V-Grip Plus – MOD. 508.141

V-Grip Maxi – MOD. 508.114

V-GRIP PLUS

3 models for lines from 10 to 16 mm available in single, double and triple.

Hard black anodized aluminium structure and AISI316 S.Steel mechanism, V shaped cam and lever. Easy opening under load for line releasing without the use of winch.

Line retrieval can be achieved with the lever closed, the line stops automatically in the new position with no slippage.

V-GRIP MAXI

5 models for lines up to 22 mm, only single version is available!

Hard black anodized aluminium structure and AISI316 S.Steel mechanism, V shaped cam and lever. Easy opening under load for line releasing without the use of winch.

Line retrieval can be achieved with the lever closed, the line stops automatically in the new position with no slippage.

Ice Yacht 52



Single

Double

Triple



V-GRIP PLUS

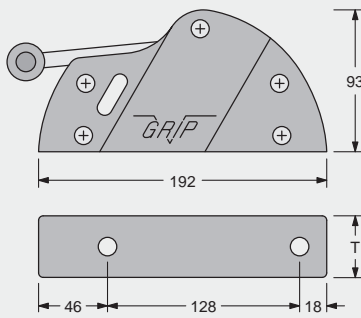

MODEL	Ø LINE mm	TYPE	T mm	WEIGHT kg	SCREWS N x Ø mm
508.121	10/12	single	41	1.10	2 x Ø10
508.122P		double	80	2.20	4 x Ø10
508.123		triple	119	3.30	6 x Ø10
508.141	12/14	single	41	1.10	2 x Ø10
508.142		double	80	2.20	4 x Ø10
508.143		triple	119	3.30	6 x Ø10
508.161	14/16	single	41	1.10	2 x Ø10
508.162		double	80	2.20	4 x Ø10
508.163		triple	119	3.30	6 x Ø10



Pegasus 50, Marine Design – Ph. Samo Vidic

V-GRIP MAXI



Single

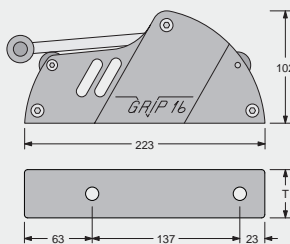

MODEL	Ø LINE mm	T mm	WEIGHT kg	SCREWS N x Ø mm
508.114	12/14	44	1.40	2 x Ø10
508.116	14/16			
508.118	16/18			
508.120	18/20			
508.122	20/22			

V-GRIP PLUS AND MAXI ORGANIZER

This solution allows manoeuvres to be guided from the clutches to the winch.

For more information see page 53.



MOD. 524.052

→	MODEL	N° SHEAVES
V-GRIP PLUS	523.042	3
	524.042	4
	525.042	5
	526.042	6
V-GRIP MAXI	523.052	3
	524.052	4
	525.052	5
	526.052	6

QR (QUICK RELEASE)

SERIES



QUICK RELEASE, DOUBLE V-GRIP

QR is the new Antal clutch that offers the highest holding power and allows you to release a line even under the maximum load. QR lets you open the handle and free the line without the aid of a winch.

Three models for 10, 12 and 14 mm line (**SWL – 1600, 2200 and 3000 kg**) are available in standard version, with mounting base or for side mounting.

DV, DOUBLE V-GRIP

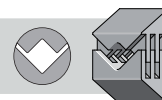

The DV-Grip is a locking system based on two opposing V shaped wedges, the result is a 4 sides grip which provides additional benefits over traditional 2-sided grip line stoppers:

- less line wear;
- higher holding power;
- smaller sizes and lower weight.

DV is a patent product by Antal.

MAXIMUM LOAD

The maximum load values are based on load tests performed on Dyneema™ and polyester lines with different covers. Dyneema™ lines with a Kevlar-polyester cover provided much better results than Dyneema™ lines with a polyester cover, which performed poorly.

The test results were even below those of a simple polyester line (polyester core and cover). The maximum load is a limit for the line, not for the clutch. Appropriate safety margins must be observed at maximum loads.

OPENING AND LOCKING

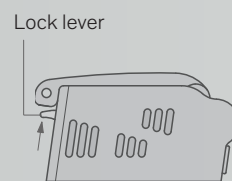
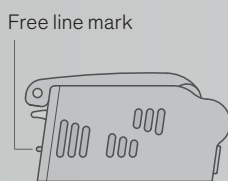
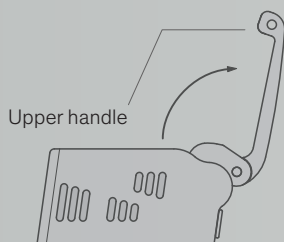

- 1 The clutch can be opened by lifting the upper handle, which can then be pushed back down.
- 2 The free-line mark is exposed and the line runs freely, even with the handle closed.
- 3 To move from free to lock, push up the lock lever. The free-line mark will disappear and the line will be locked. It is possible to recover the line in both the free and locked positions.

STANDARD MODELS

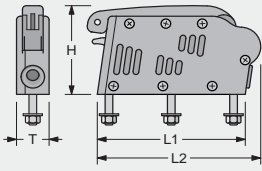

MODEL	Ø LINE mm	L1 mm	L2 mm	H mm	T mm	WEIGHT kg	STUDS N x Ø mm
506.101	10	154	170	96	34	1.00	3 x Ø8
506.121	12	176	193	101	37	1.35	3 x Ø10
506.141	14	203	222	109	40	1.70	3 x Ø10

Mounting studs, nuts and washers are **included**.

WITH MOUNTING BASE

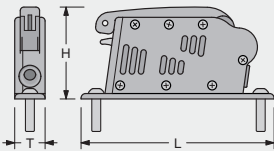

MODEL	Ø LINE mm	L mm	H mm	T mm	WEIGHT kg	FASTENERS N x Ø mm
506.106	10	216	102	34	1.12	2 x Ø10
506.126	12	249	109	37	1.52	2 x Ø12
506.146	14	280	117	40	2.10	2 x Ø12

When it is not possible to access the mounting studs from the bottom side of the clutch (for example, when mounting on a mast), Antal offers a special base that can be mounted from above with 2 screws (**included**).

SIDE-MOUNTING VERSION

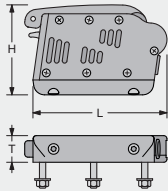

MODEL	Ø LINE mm	L mm	H mm	T mm	WEIGHT kg	STUDS N x Ø mm
506.103	10	170	115	34	1.14	3 x Ø8
506.123	12	183	125	37	1.54	3 x Ø10
506.143	14	203	133	40	1.90	2 x Ø12

QR clutches are also available for side mounting. The same model can be mounted on either the left or the right side. Screws, washers and nuts in AISI316 are **included**.

Class40 Leyton – A. Le Vaillant, Ph. Christophe Breschi



DV JAMMER

SERIES



DV JAMMER

The DV Jammer is a line holding device suitable for the extremely high loads of the high-tech Dyneema™ lines as well as exceptional holding power on polyester ropes. Six models, for lines ranging from 8 to 18 mm diameter, are available.

This covers a wide range of boats up to around 100 ft in length. DV Jammer sizes 8 and 10 have the same mounting pattern, similarly sizes 12-14 and sizes 16-18.

DV, DOUBLE V-GRIP

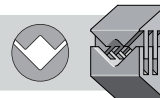

The DV-Grip is a locking system based on two opposing V shaped wedges, the result is a 4 sides grip which provides additional benefits over traditional 2-sided grip line stoppers:

- less line wear;
- higher holding power;
- smaller sizes and lower weight.

DV is a patent product by Antal.

TEST RESULTS AND MAX LOAD

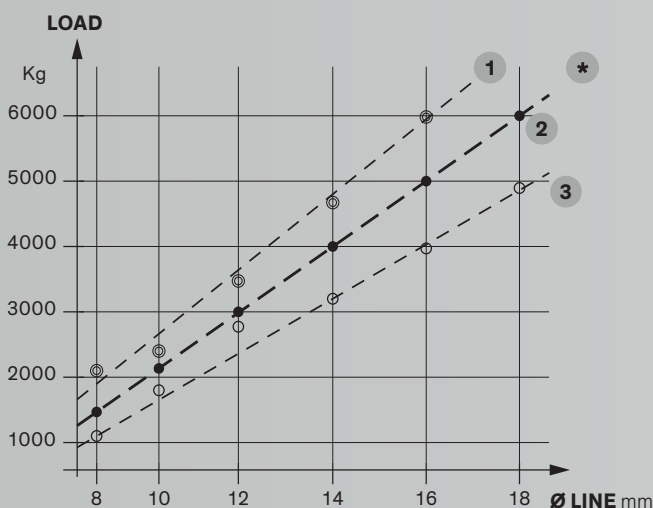

Test values were obtained on Dyneema™ lines with different covers:

- Dyneema™ with polyester cover;
- Dyneema™ with mixed Kevlar-polyester cover.

Results shown in the lower graph correspond to the failure of the cover and the resulting core slippage. Dyneema™ line with a Kevlar-Polyester cover provides much better test results than the Dyneema™ line with a Polyester cover which performed poorly, with results even below the simple polyester line (polyester cover and core).

- 1 Dyneema™ with mixed Kevlar-Polyester cover
- 2 Max loads
- 3 Dyneema™ with Polyester cover

- * Appropriate safety margins must be considered for the max loads. The suggested maximum load limit is the limit of the line. Above values for max loads are not valid for Dyneema™ lines with a polyester cover or for polyester lines with a lower breaking load value than the recommended maximum load value.

Tests with polyester lines (polyester core and cover) show that the limit is the breaking load of the line itself, with values close to our max loads.



STANDARD MODELS AND REMOTE CONTROL



DV STANDARD ↓ MODEL	REMOTE CONT. ↓ MODEL	Ø LINE mm	L mm	H mm	T mm	WEIGHT kg	STUDS N × Ø mm
505.081	505.082	8	126	86	34	0.60	4 × Ø6
505.101	505.102	10	141	90		0.69	4 × Ø8
505.121	505.122	12	169	108	42	1.20	4 × Ø10
505.141	505.142	14	185	113		1.36	
505.161	505.162	16	209	125	50	2.20	4 × Ø12
505.181	505.182	18					

Six models, for 8, 10, 12, 14, 16 and 18 mm lines are offered. A remote control version is also available: this model does not have the upper manual control slider, the opening is done with a control line. Mounting studs, nuts and washers are **included**.

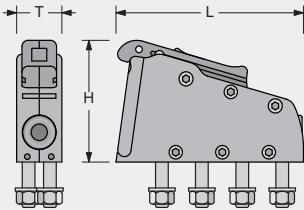

WITH MOUNTING BASE



DV STANDARD ↓ MODEL	REMOTE CONT. ↓ MODEL	Ø LINE mm	L mm	H mm	T mm	WEIGHT kg	STUDS N × Ø mm
505.086	505.087	8	134	93	34	0.69	4 × Ø6
505.106	505.107	10	149	97		0.79	4 × Ø8
505.126	505.127	12	178	118	42	1.39	4 × Ø10
505.146	505.147	14	194	123		1.57	
505.166	505.167	16	218	135	50	2.56	4 × Ø12
505.186	505.187	18					

When it is not possible to access the mounting studs/nuts/washers from the bottom side of the jammer (for example when mounting on a mast), Antal offers a special mounting base that can be mounted from above with 4 screws (**not included**).

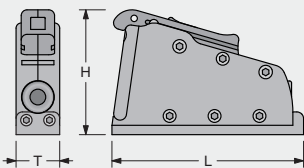

SIDE MOUNTING VERSION



DV STANDARD ↓ MODEL	REMOTE CONT. ↓ MODEL	Ø LINE mm	L mm	H mm	T mm	WEIGHT kg	STUDS N × Ø mm
505.083	505.085	8	135	95	34	0.63	4 × Ø6
505.103	505.105	10	150	99		0.72	5 × Ø6
505.123	505.125	12	179	118	42	1.22	4 × Ø8
505.143	505.145	14	195	123		1.35	5 × Ø8
505.163	505.165	16	213	135	50	2.47	6 × Ø8
505.183	505.185	18					8 × Ø8

DV Jammers are also available for side-mounting; the same model can be mounted on either left or right side. Screws, washers and nuts in AISI316 are **included**.

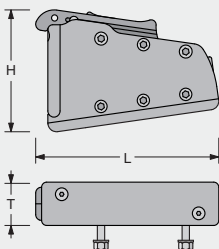

V-GRIP

SERIES

V-GRIP CLUTCHES

AISI316 S.Steel mechanism, lever and "V" shaped cam, black anodized aluminium structure.

3 models are available for 8-12, 10-14, and 12-16 mm lines in single, double and triple version.

This is the best solution when minimum sizes are required: it is only 6.8 cm high.



MOD. 507.111

Single

Double

Triple

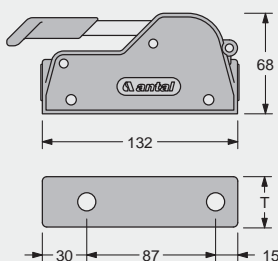

MODEL	Ø LINE mm	TYPE	T mm	WEIGHT kg	SCREWS N×Ø mm
507.111	8/10/12	single	34	0.55	2 × Ø6
507.121		double	67	1.10	4 × Ø6
507.131		triple	101	1.45	6 × Ø6
507.112	10/12/14	single	34	0.55	2 × Ø8
507.122		double	67	1.10	4 × Ø8
507.132		triple	101	1.45	6 × Ø8
507.113	12/14/16	single	34	0.55	2 × Ø8

V-GRIP ORGANIZER

This solution allows manoeuvres to be guided from the clutches to the winch. For more information see page 53.



MOD. 534.032



ORGANIZERS

DOUBLE SHEAVE ORGANIZER



MOD. 522.031

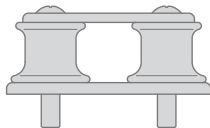

Solution designed for the Cam 611 double and triple model: mounted behind the stopper battery, it redirects the maneuver towards the winch. Resin pulleys with lateral ball bearings, black anodized aluminum carter. Fixing screws **included**.

MODEL (for CAM 611)	522.031
SHEAVES NUMBER	2
SHEAVES MATERIAL	resin
LENGTH mm	88
WEIGHT kg	0.16
SWL* kg	1000 kg
A mm	22
B mm	50
C mm	28
H mm	36
SCREWS N x Ø mm	2 x Ø8

V-GRIP ORGANIZER

This solution allows manoeuvres to be guided from the clutches to the winch. Fixing screws **included**.



MOD. 525.052

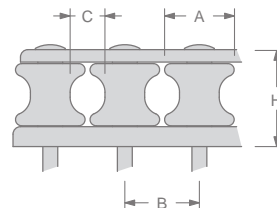

→	MODEL	SHEAVES		LENGTH mm	WEIGHT kg	SWL* kg	A mm	B mm	C mm	H mm	SCREWS N x Ø mm
		N	MATERIAL								
V-CAM R814 V-CAM 814	513.032	3	resin	90	0.18	500	28	30	14	39	3 x Ø6
	514.032	4		120	0.22						4 x Ø6
	515.032	5		150	0.27						5 x Ø6
	516.032	6		180	0.32						6 x Ø6
	517.032	7		210	0.37						7 x Ø6
V-GRIP PLUS	523.042	3	aluminium	125	0.43	1000	38	39	16	46	3 x Ø8
	524.042	4		165	0.57						4 x Ø8
	525.042	5		205	0.71						5 x Ø8
	526.042	6		245	0.85						6 x Ø8
V-GRIP MAXI	523.052	3	aluminium	138	0.50	1000	43	44	18	46	3 x Ø8
	524.052	4		182	0.65						4 x Ø8
	525.052	5		226	0.83						5 x Ø8
	526.052	6		270	1.00						6 x Ø8
V-GRIP	533.032	3	resin	100	0.19	500	28	35	19	38	3 x Ø6
	534.032	4		135	0.24						4 x Ø6
	535.032	5		170	0.30						5 x Ø6
	536.032	6		205	0.35						6 x Ø6

* SWL refers to the single sheave.

SWIVELLING CAM-CLEATS

SERVO CLEAT

The particular stainless and plastic cam teeth conformation is designed to make line inserting between cams easy. Made of plastic with S.Steel "ribs". Screws are **included**.

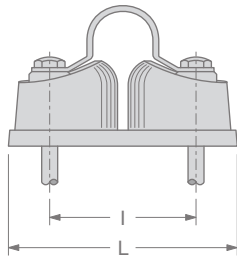

MODEL	Ø LINE mm	I mm	L mm	SCREWS N×Ø mm	WEIGHT* g
502.011	3 / 7	27	48	2×Ø4	35.0
502.22/37	6 / 10	37	64	2×Ø5	79.5
502.022	6 / 12	42	70	2×Ø5	85.1
502.033	10 / 14	52	86	2×Ø6	135.4

* Fixing screws are **included**.

SWIVELLING CLEAT

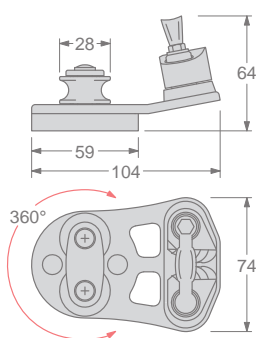

The aluminium base swivels through 360° on single races of Torlon ball bearings. The system is fitted with 2 × 28 mm sheaves for lines up to 10 mm.

MOD. 522.022

Fixing – 3 × Ø5 mm screws (**included**)

Weight – 0.23 kg

SWL – 150 kg (on the cam cleat)

BLOCK AND SERVO CLEAT

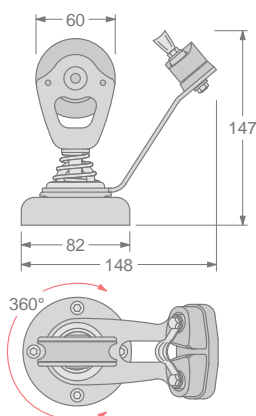

The aluminium base swivels through 360° on double races of Torlon ball bearings. The system is completed with a 60 mm block for lines up to 12 mm.

MOD. 522.140

Fixing – 4 × Ø6 mm screws (**included**)

Weight – 0.82 kg

SWL – 200 kg (on the cam cleat)

STOPPER DECK-BLOCKS

The sheaves are made of **high strength resin**, fitted with composite fibre bush and side ball-bearings. No maintenance or lubrication is required.

The machined side plates are made of **high strength alloy**, hard black anodized for wear and corrosion proofing and with all the edges smoothed off. The aluminium locking cam is fitted on an automatic opening spring: relaxing the sheet is sufficient to open the jammer.

Compact design with the lever fully concealed with in the side plates and with recessed fasteners. The cam cannot be locked under high loads. It's intended to hold the line temporarily and not under heavy loads. Left and right versions are available.

Mounting screws, nuts and washers are **included**.



MODEL	Ø LINE mm	D mm	L mm	SWL kg	WEIGHT kg	SCREWS N x Ø mm
↓ SINGLE						
851.065*	6 / 12	65	116	800	0.23	2 x Ø8
851.080	6 / 14	80	131	1000	0.33	2 x Ø8
851.100	6 / 16	100	152	2000	0.65	2 x Ø10
851.125	10 / 18	125	174	3500	1.10	4 x Ø10
↓ DOUBLE						
852.065*	6 / 12	65	116	800	0.38	2 x Ø8
852.080	6 / 14	80	131	1000	0.56	2 x Ø8
852.100	8 / 16	100	152	2000	1.50	2 x Ø10
852.125	10 / 18	125	174	3500	1.85	4 x Ø10

* In the smallest model (D = 65) there is no spring for the cam opening.

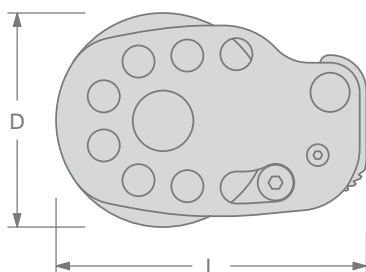

Left and right versions are available, just add **LEFT** or **RIGHT** to the model code when ordering.



Rosso Ragno 28 – Ph. A. Righetti



antail
Cooper 120 x 18

COOPER

BLOCKS



Mini S.Steel 58



OPF 62



XXL 76



Looper 80



A316 S.Steel 84



Hollow Pin deck-blocks 92



Mast blocks 95



Organizers 96



Tulip 97



Special blocks 101



Dynablocks 105



Snatch blocks 106

MINI S.STEEL

SERIES

MOD. 00301



MINI BLOCKS 34x6 AND 40x8 SERIES

This series offers extremely high working loads (SWL $34 \times 6 = 400$ kg, $40 \times 8 = 500$ kg) while still compact and lightweight. The sheave is made of resin with a double lateral ball-bearing. Cheekplates are made of perfectly polished AISI 316 stainless steel. The high quality materials guarantee a maintenance-free product.

↓ SHEAVE

Resin sheave with double Self Captive ball bearings.



MOD. 03411M

Ø – 34 mm
LINE – 6 mm
SWL – 400 kg

MOD. 04013M

Ø – 40 mm
LINE – 8 mm
SWL – 500 kg

MOD. 00302



↓ CAM CLEAT

All models can be supplied with Cam Cleat. Just add **C** to the model code when ordering.



34x6

SIZE – 34x6
WEIGHT – (+)42 g
MAX LOAD – 80 kg

40x8

SIZE – 40x8
WEIGHT – (+)42 g
MAX LOAD – 80 kg

↓ SWIVEL HEAD

All models are available with swivel head, just add **SW** to the model code when ordering.



34x6

SIZE – 34x6
WEIGHT – (+)15 g
MAX LOAD – 400 kg

40x8

SIZE – 40x8
WEIGHT – (+)20 g
MAX LOAD – 500 kg





MOD. 00301

SHACKLE BLOCK
WEIGHT – 44 g
SWL – 400 kg



MOD. 00302

SINGLE BECKET
WEIGHT – 52 g
SWL – 400 kg



MOD. 00303

DOUBLE BLOCK
WEIGHT – 82 g
SWL – 600 kg



MOD. 00304

DOUBLE BECKET
WEIGHT – 90 g
SWL – 600 kg



MOD. 00305

TRIPLE BLOCK
WEIGHT – 94 g
SWL – 600 kg



MOD. 00306

TRIPLE BECKET
WEIGHT – 102 g
SWL – 600 kg



MOD. 00320

SINGLE U-HEAD
WEIGHT – 40 g
SWL – 400 kg



MOD. 00321

U-HEAD BECKET
WEIGHT – 43 g
SWL – 400 kg



MOD. 00330

FIDDLE BLOCK
WEIGHT – 65 g
SWL – 400 kg



MOD. 00331

FIDDLE BECKET
WEIGHT – 76 g
SWL – 400 kg



MOD. 00311

FOOT BLOCK
WEIGHT* – 36 g • SWL – 400 kg
SCREWS – 2xØ6 mm (included)



MOD. 00316

STAND-UP
WEIGHT* – 46 g • SWL – 400 kg
SCREWS – 1xØ6 mm (included)



MOD. 00322

SADDLE BLOCK
WEIGHT* – 46 g • SWL – 400 kg
SCREWS – 2xØ5 mm (included)



MOD. 03413M

This sheave is supplied with models **00323** and **00324**.

Ø – 34 mm
LINE – 8 mm
SWL – 400 kg



MOD. 00323

UPRIGHT
WEIGHT* – 55 g • SWL – 400 kg
SCREWS – 2xØ5 mm (included)



MOD. 00324

OVER THE TOP
WEIGHT* – 65 g • SWL – 400 kg
SCREWS – 2xØ5 mm (included)

* Screws **not** included.

↓ MULTIPLE VERTICAL BLOCKS

The vertical blocks (**MOD. 00323** and **00324** on page 59, **MOD. 00423** and **00424** on page 60) can be grouped in battery, joined by a central pivot. Add the number of elements to the model code, as in the following example: **00323/2**, **00323/3**, **00323/n** respectively for batteries from 2, 3, N° pieces.





MOD. 00401

SHACKLE BLOCK
WEIGHT – 62 g
SWL – 500 kg



MOD. 00402

SINGLE BECKET
WEIGHT – 73 g
SWL – 500 kg



MOD. 00403

DOUBLE BLOCK
WEIGHT – 115 g
SWL – 600 kg



MOD. 00404

DOUBLE BECKET
WEIGHT – 126 g
SWL – 600 kg



MOD. 00405

TRIPLE BLOCK
WEIGHT – 132 g
SWL – 600 kg



MOD. 00406

TRIPLE BECKET
WEIGHT – 143 g
SWL – 600 kg



MOD. 00420

SINGLE U-HEAD
WEIGHT – 56 g
SWL – 500 kg



MOD. 00421

U-HEAD BECKET
WEIGHT – 60 g
SWL – 500 kg



MOD. 00430

FIDDLE BLOCK
WEIGHT – 91 g
SWL – 500 kg



MOD. 00431

FIDDLE BECKET
WEIGHT – 106 g
SWL – 500 kg



MOD. 00411

FOOT BLOCK
WEIGHT* – 50 g • SWL – 500 kg
SCREWS – 2xØ6 mm (included)



MOD. 04514M

This sheave is supplied with models **00423** and **00424**.

Ø – 45 mm
LINE – 8 mm
SWL – 600 kg



MOD. 00416

STAND-UP
WEIGHT* – 64 g • SWL – 500 kg
SCREWS – 1xØ6 mm (included)



MOD. 00423

UPRIGHT
WEIGHT* – 77 g • SWL – 600 kg
SCREWS – 2xØ6 mm (included)



MOD. 00422

SADDLE BLOCK
WEIGHT* – 64 g • SWL – 500 kg
SCREWS – 2xØ5 mm (included)



MOD. 00424

OVER THE TOP
WEIGHT* – 91 g • SWL – 600 kg
SCREWS – 2xØ6 mm (included)

* Screws **not** included.



BLOCKS AND TACKLES

MINI 40

40 mm SHEAVE for 8 mm LINE – SAFE WORKING LOAD = 500 kg

The heads of these blocks are closed with a removable screw for an easy connection with a spliced line. Four models: single, single-becket, fiddle and fiddle-becket, to assemble the tackles with 2:1, 3:1 and 4:1 power ratios. Lines are **not included**.

dle-becket, to assemble the tackles with 2:1, 3:1 and 4:1 power ratios. Lines are **not included**.

POWER RATIO 2:1

MOD. 00401B

SINGLE BLOCK
WEIGHT – 58 g
SWL – 500 kg

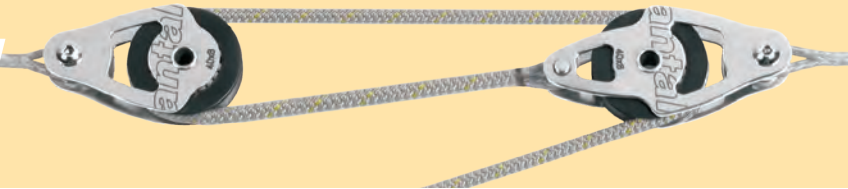

MOD. 00402B

SINGLE BECKET
WEIGHT – 68 g
SWL – 500 kg

POWER RATIO 3:1

MOD. 00402B

SINGLE BECKET
WEIGHT – 68 g
SWL – 500 kg

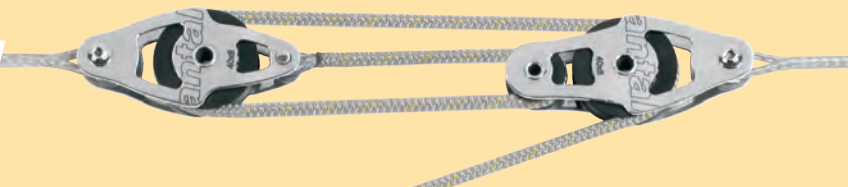

MOD. 00430B

FIDDLE BLOCK
WEIGHT – 80 g
SWL – 500 kg

POWER RATIO 4:1

MOD. 00430B

FIDDLE BLOCK
WEIGHT – 80 g
SWL – 500 kg



MOD. 00431B

FIDDLE BECKET
WEIGHT – 90 g
SWL – 500 kg

OPF SERIES

MOD. 01001



OPF SERIES

One Piece Frame block by Antal, the block without pins or screws, it is a light and strong solution: simply a hard black anodized and teflon coated aluminium frame in one piece.

A complete range from **50** to **140** mm sheaves in single, double, triple, fiddle, and deck versions, for webbing or shackle connection. Sizes are based on the range of HR shackles available and on their safe working load (SWL).

↓ THE "COMPOSITE FIBRE" SHEAVE

The resin (aluminium on larger mod) sheave runs on the main Composite Fibre bearing and on a ground S.Steel hub: low friction highloads, no lubricant required.

The Self Captive side ball bearing reduces the friction and makes disassembling, cleaning and maintenance very easy. Sheaves are supplied with the S.Steel hub, they are available separately.

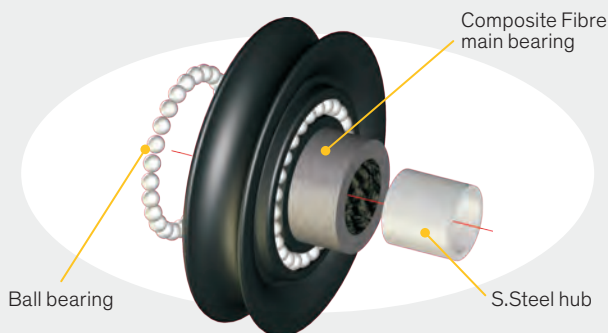

↓ THE HR SWIVEL HEAD



Made in high resistance S.Steel, with three positions: swivelling head, longitudinal lock and transversal lock. HR shackles **included**.

↓ THE "ONE PIECE FRAME"



The one-piece aluminium extruded body is the strongest and lightest solution, no assembling pin rivets or screws and nuts.

CNC machined polished, hard black anodized and teflon coated.

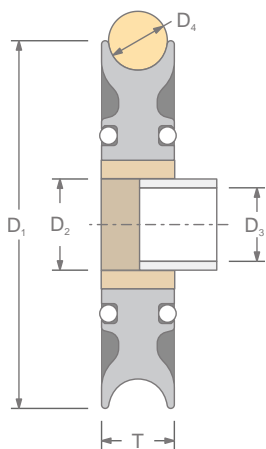

SHEAVE	D ₁ mm	T mm	MATERIAL	D ₂ mm	D ₃ mm	D ₄ mm	SWL kg	WEIGHT g
04919F	48	18	resin	20	16	15	200	43
05114M*	50	14	resin	12	8	10	600	30
06016F	60	16	resin	15	12	12	800	46
06421F	64	21	resin	25	20	16	1750	78
07016F	70	16	resin	15	12	12	1300	66
08019F	80	19	resin	20	16	14	2200	98
10021A	100	21	aluminium	25	20	16	3500	164
12025A	120	25	aluminium	30	24	18	5000	420
14025A	140	25	aluminium	40	32	20	7000	580

* Without Composite Fibre main bearing.

SPECIAL HEADS

On request Antal blocks are supplied with special head: long head or Wichard HR snap shackle.

LONG HEAD

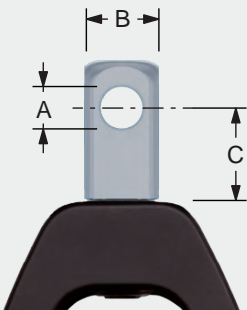

MODEL	SHEAVE Ø mm	A mm	B mm	C mm	B.B. CAR SIZE mm
J	60	6	12	12	100
J	70				110
J1	70/80	8	14.5	14.5	150
J2	80	10	18	17	190
J1	100			19	
J2	100			25	260

For stand-up connection of ball bearing cars (page 130, 134-137).
To order the block with this special long swivel head, add **J** to the block model code.

SNAP SHACKLE*

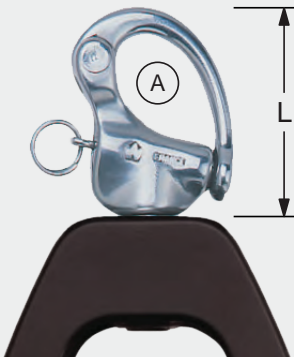

MODEL	SHEAVE Ø mm	SWL** kg	BL** kg	A mm	L mm
SN	50	700	1370	16	45
	60				
	70	960	2000	16	45
	80	1280	3600	21	60
	100	2800	7000	26	80

* Snap shackle → this solution is available for single and fiddle blocks only. To order the block with this special snap shackle head, add **SN** to the block model code. AISI 316 snap shackle for size 50 and 60, Wichard HR snap shackles for all the others.

** **SWL** (Safe Working Load) and **BL** (Breaking Load) declared by the manufacturers.

CAM-CLEAT ASSEMBLY



MODEL	CAM CLEAT ASSEMBLY	SHEAVE Ø mm	WEIGHT kg
C	YBA049	50	0.08
	YBA052	60	0.13
	YBA056	70	0.15

It is available for all the 50, 60 and 70 mm diameter models. Adjustable in 3 positions.
To order the block with cam-cleat, add **C** to the block model code.

Antal blocks of the OPF series are supplied with shackles: AISI 316 on size 50 and 60 and HR on size 70 and more.

For the breaking (**BL**) and the safe working loads (**SWL**) of the shackles, consider the tables on page 207.



MOD. 00501

SWIVEL BLOCK
WEIGHT* – 90 g
SWL – 600 kg • SHACKLE – 5 mm



MOD. 00502

BECKET BLOCK
WEIGHT* – 104 g
SWL – 600 kg • SHACKLE – 5 mm



MOD. 00503

DOUBLE SHEAVE
WEIGHT* – 169 g
SWL – 800 kg • SHACKLE – 6 mm



MOD. 00504

DOUBLE BECKET
WEIGHT* – 184 g
SWL – 800 kg • SHACKLE – 6 mm



MOD. 00505

TRIPLE SHEAVE
WEIGHT* – 225 g
SWL – 800 kg • SHACKLE – 6 mm



MOD. 00506

TRIPLE BECKET
WEIGHT* – 240 g
SWL – 800 kg • SHACKLE – 6 mm



MOD. 00507

SINGLE FIDDLE
WEIGHT* – 122 g
SWL – 600 kg • SHACKLE – 5 mm



MOD. 00508

BECKET FIDDLE
WEIGHT* – 136 g
SWL – 600 kg • SHACKLE – 5 mm

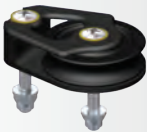

MOD. 00511

FOOT BLOCK
WEIGHT** – 71 g • **SWL – 600 kg**
SCREWS – 2xØ6 mm (included)



MOD. 00512

DOUBLE FOOT
WEIGHT** – 141 g • **SWL – 600 kg**
SCREWS – 3xØ6 mm (included)



MOD. 00516

VERTICAL FIX
WEIGHT** – 75 g • **SWL – 600 kg**
SCREWS – 2xØ6 mm (included)



MOD. 00517

UP-DOWN
WEIGHT** – 89 g • **SWL – 600 kg**
SCREWS – 2xØ6 mm (included)

In the OPF 50 series sheaves are **riveted** and **not removable**.
The Cam Cleat cannot be sold separately, nor added later.

↓ CAM CLEAT

With 3 different positions for single, double and triple. For blocks with cleat add **C** to the block model code.

SWL – 100 kg
WEIGHT +0.08 kg

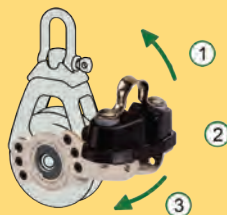

Full scale pic →
MOD. 00501



WEB → For line connection



MOD. 00509

SIMPLE WEB
WEIGHT* – 64 g
SWL – 600 kg



MOD. 00510

BECKET WEB
WEIGHT* – 78 g
SWL – 600 kg



MOD. 00507/9

SINGLE FIDDLE WEB
WEIGHT* – 85 g
SWL – 600 kg



MOD. 00508/9

BECKET FIDDLE WEB
WEIGHT* – 100 g
SWL – 600 kg



MOD. 00513

BLOCK U-BOLT
WEIGHT – 129 g • SWL – 500 kg
SCREWS – 2xØ5 mm (included)



MOD. 7105

Page 207 → More info

↓ Swivel head locks and shackles are always **included**, but they are available separately. ↓

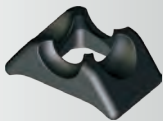

MOD. Y-B0746

Longitudinal or transversal head lock for single blocks.

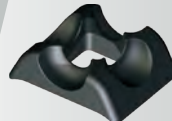

MOD. Y-B0747

Longitudinal or transversal head lock for double and triple blocks.



MOD. 005SS

5 mm SHACKLE (AISI316)
WEIGHT – 15 g • SWL – 600 kg
For single blocks



MOD. 006SS

6 mm SHACKLE (AISI316)
WEIGHT – 26 g • SWL – 800 kg
For double and triple blocks





MOD. 00601

SWIVEL BLOCK
WEIGHT* – 0.16 kg
SWL – 800 kg • SHACKLE – 6 mm



MOD. 00602

BECKET BLOCK
WEIGHT* – 0.18 kg
SWL – 800 kg • SHACKLE – 6 mm



MOD. 00603

DOUBLE SHEAVE
WEIGHT* – 0.31 kg
SWL – 1300 kg • SHACKLE – 8 mm



MOD. 00604

DOUBLE BECKET
WEIGHT* – 0.33 kg
SWL – 1300 kg • SHACKLE – 8 mm



MOD. 00605

TRIPLE SHEAVE
WEIGHT* – 0.41 kg
SWL – 1300 kg • SHACKLE – 8 mm



MOD. 00606

TRIPLE BECKET
WEIGHT* – 0.43 kg
SWL – 1300 kg • SHACKLE – 8 mm



MOD. 00607

SINGLE FIDDLE
WEIGHT* – 0.21 kg
SWL – 800 kg • SHACKLE – 6 mm



MOD. 00608

BECKET FIDDLE
WEIGHT* – 0.23 kg
SWL – 800 kg • SHACKLE – 6 mm



MOD. 00609

SIMPLE WEB
WEIGHT* – 0.10 kg
SWL – 800 kg • For line connection



MOD. 00610

WEB BECKET
WEIGHT* – 0.12 kg
SWL – 800 kg • For line connection



↓ CAM CLEAT

With 3 different positions for single, double and triple. For blocks with cleat add **C** to the block model code.

SWL – 150 kg
WEIGHT +0.13 kg

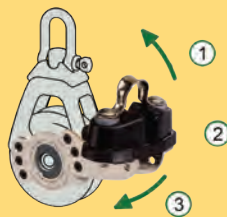

Full scale pic →
MOD. 00601

* With shackle – ** Without screws



RM 970 – Ph. A. De Buyzer





MOD. 00611

FOOT BLOCK
WEIGHT** – 0.13 kg • **SWL – 800 kg**
SCREWS – 2xØ6 mm (included)



MOD. 00612

DOUBLE FOOT
WEIGHT** – 0.23 kg • **SWL – 800 kg**
SCREWS – 3xØ6 mm (included)



MOD. 00616

VERTICAL FIX
WEIGHT** – 0.14 kg • **SWL – 800 kg**
SCREWS – 2xØ6 mm (included)



MOD. 00617

UP-DOWN
WEIGHT** – 0.18 kg • **SWL – 800 kg**
SCREWS – 2xØ6 mm (included)



MOD. 00613

BLOCK U-BOLT
WEIGHT – 0.22 kg • **SWL – 800 kg**
SCREWS – 2xØ6 mm (included)



MOD. 7106

Page 207 → More info



MOD. 00614

BLOCK PAD-EYE
WEIGHT – 0.26 kg • **SWL – 800 kg**
SCREWS – 2xØ6 mm (included)



MOD. 7206

Page 204 → More info



MOD. 00615

BLOCK SCREWED
WEIGHT – 0.32 kg • **SWL – 800 kg**
SCREWS – 2xØ6 mm (included)



MOD. 7306

Page 205 → More info

↓ Swivel head locks and shackles are always **included**, but they are available separately. ↓

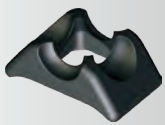

MOD. Y-B0748

Longitudinal or transversal head lock for single blocks.

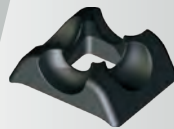

MOD. Y-B0749

Longitudinal or transversal head lock for double and triple blocks.



MOD. 005SS

6 mm SHACKLE (AISI316)
WEIGHT – 26 g • **SWL – 800 kg**
For single blocks



MOD. 006SS

8 mm SHACKLE (AISI316)
WEIGHT – 62 g • **SWL – 1300 kg**
For double and triple blocks

Revolver





MOD. 00701
SWIVEL BLOCK
 WEIGHT* – 0.20 kg
SWL – 1300 kg • HR SHACKLE – 6 mm



MOD. 00709
SIMPLE WEB
 WEIGHT – 0.14 kg
SWL – 1300 kg • For line connection



MOD. 00702
BECKET BLOCK
 WEIGHT* – 0.22 kg
SWL – 1300 kg • HR SHACKLE – 6 mm



MOD. 00710
WEB BECKET
 WEIGHT – 0.16 kg
SWL – 1300 kg • For line connection



MOD. 00703
DOUBLE SHEAVE
 WEIGHT* – 0.38 kg
SWL – 2200 kg • HR SHACKLE – 8 mm



MOD. 00704
DOUBLE BECKET
 WEIGHT* – 0.40 kg
SWL – 2200 kg • HR SHACKLE – 8 mm



MOD. 00705
TRIPLE SHEAVE
 WEIGHT* – 0.50 kg
SWL – 2200 kg • HR SHACKLE – 8 mm



MOD. 00706
TRIPLE BECKET
 WEIGHT* – 0.52 kg
SWL – 2200 kg • HR SHACKLE – 8 mm



MOD. 00707
SINGLE FIDDLE
 WEIGHT* – 0.26 kg
SWL – 1300 kg • HR SHACKLE – 6 mm



MOD. 00708
BECKET FIDDLE
 WEIGHT* – 0.28 kg
SWL – 1300 kg • HR SHACKLE – 6 mm

↓ CAM CLEAT

With 3 different positions for single, double and triple. For blocks with cleat add **C** to the block model code.

SWL – 150 kg
 WEIGHT +0.15 kg

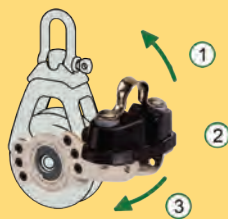

Full scale pic →
MOD. 00701

* With shackle – ** Without screws

Brenta Yachts B34



↓ Swivel head locks and shackles are always **included**, but they are available separately. ↓



MOD. Y-B0748

Longitudinal or transversal head lock for single blocks.

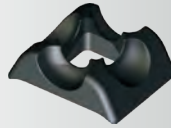

MOD. Y-B0749

Longitudinal or transversal head lock for double and triple blocks.



MOD. 006HR

6 mm HR SHACKLE
WEIGHT – 26 g • SWL – 1300 kg
For single blocks



MOD. 008HR

8 mm HR SHACKLE
WEIGHT – 62 g • SWL – 2200 kg
For double and triple blocks



Transat Jaques Vabre, A. Fornaro – Ph. M. Paolillo



MOD. 00711

FOOT BLOCK
WEIGHT** – 0.16 kg • SWL – 1300 kg
SCREWS – 2xØ8 mm (included)



MOD. 00712

DOUBLE FOOT
WEIGHT** – 0.26 kg • SWL – 1300 kg
SCREWS – 3xØ8 mm (included)



MOD. 00716

VERTICAL FIX
WEIGHT** – 0.18 kg • SWL – 1300 kg
SCREWS – 2xØ8 mm (included)



MOD. 00717

UP-DOWN
WEIGHT** – 0.20 kg • SWL – 1300 kg
SCREWS – 2xØ8 mm (included)



MOD. 00713

BLOCK U-BOLT
WEIGHT – 0.32 kg • SWL – 1300 kg
SCREWS – 2xØ8 mm (included)

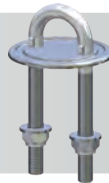

MOD. 7108

Page 207 → More info



MOD. 00714

BLOCK PAD-EYE
WEIGHT – 0.41 kg • SWL – 1300 kg
SCREWS – 4xØ6 mm (included)



MOD. 7208

Page 204 → More info



MOD. 00715

BLOCK SCREWED
WEIGHT – 0.75 kg • SWL – 1300 kg
SCREWS – 4xØ6 mm (included)



MOD. 7308

Page 205 → More info



MOD. 00801
SWIVEL BLOCK
 WEIGHT* – 0.34 kg
SWL – 2200 kg • HR SHACKLE – 8 mm



MOD. 00802
BECKET BLOCK
 WEIGHT* – 0.38 kg
SWL – 2200 kg • HR SHACKLE – 8 mm



MOD. 00809
SIMPLE WEB
 WEIGHT – 0.22 kg
SWL – 2200 kg • For line connection



MOD. 00810
WEB BECKET
 WEIGHT – 0.26 kg
SWL – 2200 kg • For line connection



MOD. 00807
SIMPLE FIDDLE
 WEIGHT* – 0.44 kg
SWL – 2200 kg • HR SHACKLE – 8 mm



MOD. 00808
BECKET FIDDLE
 WEIGHT* – 0.48 kg
SWL – 2200 kg • HR SHACKLE – 8 mm

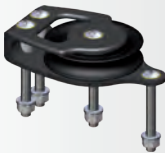

MOD. 00811
FOOT BLOCK
 WEIGHT** – 0.29 kg • **SWL – 2200 kg**
 SCREWS – 4xØ8 mm (included)



MOD. 00803
DOUBLE BLOCK
 WEIGHT* – 0.54 kg
SWL – 3500 kg • HR SHACKLE – 10 mm



MOD. 00812
DOUBLE FOOT
 WEIGHT** – 0.57 kg • **SWL – 2200 kg**
 SCREWS – 4xØ8 mm (included)

* With shackle
 ** Without screws
 Full scale pic →



→ **MOD. 7110** (page 207)
MOD. 00813
BLOCK U-BOLT
 WEIGHT – 0.54 kg • **SWL – 2200 kg**
 SCREWS – 2xØ10 mm (included)

MOD. 00801



→ **MOD. 7210** (page 204)
MOD. 00814
BLOCK PAD-EYE
 WEIGHT – 0.61 kg • **SWL – 2200 kg**
 SCREWS – 4xØ8 mm (included)



→ **MOD. 7310** (page 205)
MOD. 00815
BLOCK SCREWED
 WEIGHT – 0.93 kg • **SWL – 2200 kg**
 SCREWS – 4xØ8 mm (included)



MOD. 00816
VERTICAL FIX
 WEIGHT** – 0.27 kg • **SWL – 2200 kg**
 SCREWS – 2xØ10 mm (included)

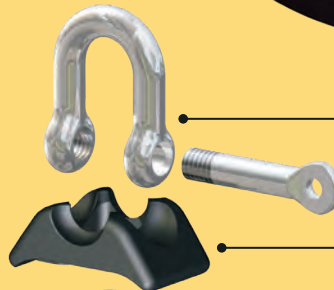

MOD. 008HR
 HR SHACKLE, Ø8 mm
 WEIGHT – 62 g
SWL – 2200 kg

MOD. Y-B0750
 For longitudinal or transversal head lock.
 Swivel head lock and shackle are included.



MOD. 01001

SWIVEL BLOCK
WEIGHT* – 0.63 kg
SWL – 3500 kg • HR SHACKLE – 10 mm



MOD. 01002

BECKET BLOCK
WEIGHT* – 0.70 kg
SWL – 3500 kg • HR SHACKLE – 10 mm



MOD. 01009

SIMPLE WEB
WEIGHT – 0.41 kg
SWL – 3500 kg • For line connection



MOD. 01010

WEB BECKET
WEIGHT – 0.48 kg
SWL – 3500 kg • For line connection



MOD. 01007

SIMPLE FIDDLE
WEIGHT* – 0.90 kg
SWL – 3500 kg • HR SHACKLE – 10 mm



MOD. 01008

BECKET FIDDLE
WEIGHT* – 0.90 kg
SWL – 3500 kg • HR SHACKLE – 10 mm



MOD. 01003

DOUBLE BLOCK
WEIGHT* – 1.02 kg
SWL – 5000 kg • HR SHACKLE – 12 mm

Full scale pic →

MOD. 01001



MOD. 01011

FOOT BLOCK
WEIGHT** – 0.56 kg • SWL – 3500 kg
SCREWS – 4xØ10 mm + 1xØ8 mm (incl.)



MOD. 01012

DOUBLE FOOT
WEIGHT** – 1.29 kg • SWL – 3500 kg
SCREWS – 4xØ10 mm + 1xØ8 mm (incl.)



→ **MOD. 7212** (page 204)

MOD. 01014

BLOCK PAD-EYE
WEIGHT – 1.01 kg • SWL – 3500 kg
SCREWS – 4xØ8 mm (included)



→ **MOD. 7312** (page 205)

MOD. 01015

BLOCK SCREWED
WEIGHT – 1.35 kg • SWL – 3500 kg
SCREWS – 4xØ10 mm (included)



MOD. 01016

VERTICAL FIX
WEIGHT** – 0.63 kg • SWL – 3500 kg
SCREWS – 2xØ12 mm (included)



MOD. 010HR
HR SHACKLE, Ø10 mm
WEIGHT – 114 g
SWL – 3500 kg



MOD. Y-B0751
For longitudinal or transversal head lock. Swivel head lock and shackle are included.

* With shackle – ** Without screws



MOD. 01201

SWIVEL BLOCK
WEIGHT* – 1.08 kg
SWL – 5000 kg • HR SHACKLE – 12 mm



MOD. 01216Z

VERTICAL FIX
WEIGHT** – 1.25 kg • **SWL – 7000 kg**
SCREWS – 3×Ø14 mm (included)



MOD. 01202

BECKET BLOCK
WEIGHT* – 1.22 kg
SWL – 5000 kg • HR SHACKLE – 12 mm



MOD. 01216

VERTICAL FIX
WEIGHT** – 0.96 kg • **SWL – 5000 kg**
SCREWS – 2×Ø14 mm (included)



MOD. 01209

SIMPLE WEB
WEIGHT – 0.74 kg
SWL – 5000 kg • For line connection



Full scale pic →

MOD. 01201



MOD. 01210

WEB BECKET
WEIGHT – 0.88 kg
SWL – 5000 kg • For line connection

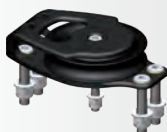

MOD. 01211

FOOT BLOCK
WEIGHT** – 0.80 kg • **SWL – 5000 kg**
SCREWS – 5×Ø10 mm (included)



MOD. 01212

DOUBLE FOOT
WEIGHT** – 1.97 kg • **SWL – 5000 kg**
SCREWS – 5×Ø10 mm (included)



→ **MOD. 7214** (page 204)

MOD. 01214

BLOCK PAD-EYE
WEIGHT – 1.70 kg • **SWL – 5000 kg**
SCREWS – 4×Ø10 mm (not included)



→ **MOD. 7314** (page 205)

MOD. 01215

BLOCK SCREWED
WEIGHT – 2.00 kg • **SWL – 5000 kg**
SCREWS – 4×Ø10 mm (not included)



MOD. 012HR
HR SHACKLE, Ø12 mm
WEIGHT – 186 g
SWL – 5000 kg



MOD. Y-B0752
For longitudinal or transversal head lock. Swivel head lock and shackle are included.



MOD. 01401

SWIVEL BLOCK
WEIGHT* – 1.50 kg
SWL – 7000 kg • HR SHACKLE – 14 mm



MOD. 01402

BECKET BLOCK
WEIGHT* – 1.70 kg
SWL – 7000 kg • HR SHACKLE – 14 mm



MOD. 01409

SIMPLE WEB
WEIGHT – 1.08 kg
SWL – 7000 kg • For line connection



Full scale pic →

MOD. 01401



MOD. 01410

WEB BECKET
WEIGHT – 1.28 kg
SWL – 7000 kg • For line connection

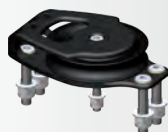

MOD. 01411

FOOT BLOCK
WEIGHT** – 1.25 kg • **SWL – 7000 kg**
SCREWS – 5×Ø12 mm (included)



MOD. 01412

DOUBLE FOOT
WEIGHT** – 2.60 kg • **SWL – 7000 kg**
SCREWS – 5×Ø12 mm (included)



→ **MOD. 7216** (page 204)

MOD. 01414

BLOCK PAD-EYE
WEIGHT – 2.60 kg • **SWL – 7000 kg**
SCREWS – 6×Ø10 mm (not included)



→ **MOD. 7316** (page 205)

MOD. 01415

BLOCK SCREWED
WEIGHT – 3.70 kg • **SWL – 7000 kg**
SCREWS – 6×Ø10 mm (not included)

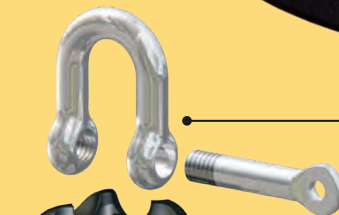

MOD. 014HR
HR SHACKLE, Ø14 mm
WEIGHT – 298 g
SWL – 6500 kg

MOD. Y-B0846
For longitudinal or transversal head lock. Swivel head lock and shackle are included.

* With shackle – ** Without screws

MAINSHEET SYSTEMS

MAINSHEET SYSTEMS

These systems are particularly suitable for the mainsheet control. **2 sizes** are available:

Size 60 for boats up to 36 ft and lines up to $\varnothing = 10$ mm, main sheave with Cam Cleat $\varnothing = 60$ mm, secondary sheave $\varnothing = 50$ mm, SWL (safe working load) = 800 kg.

Size 75 for boats up to 40 ft and lines up to $\varnothing = 12$ mm, main sheave with Cam Cleat $\varnothing = 75$ mm, secondary sheave $\varnothing = 60$ mm, safe working load SWL = 1000 kg.

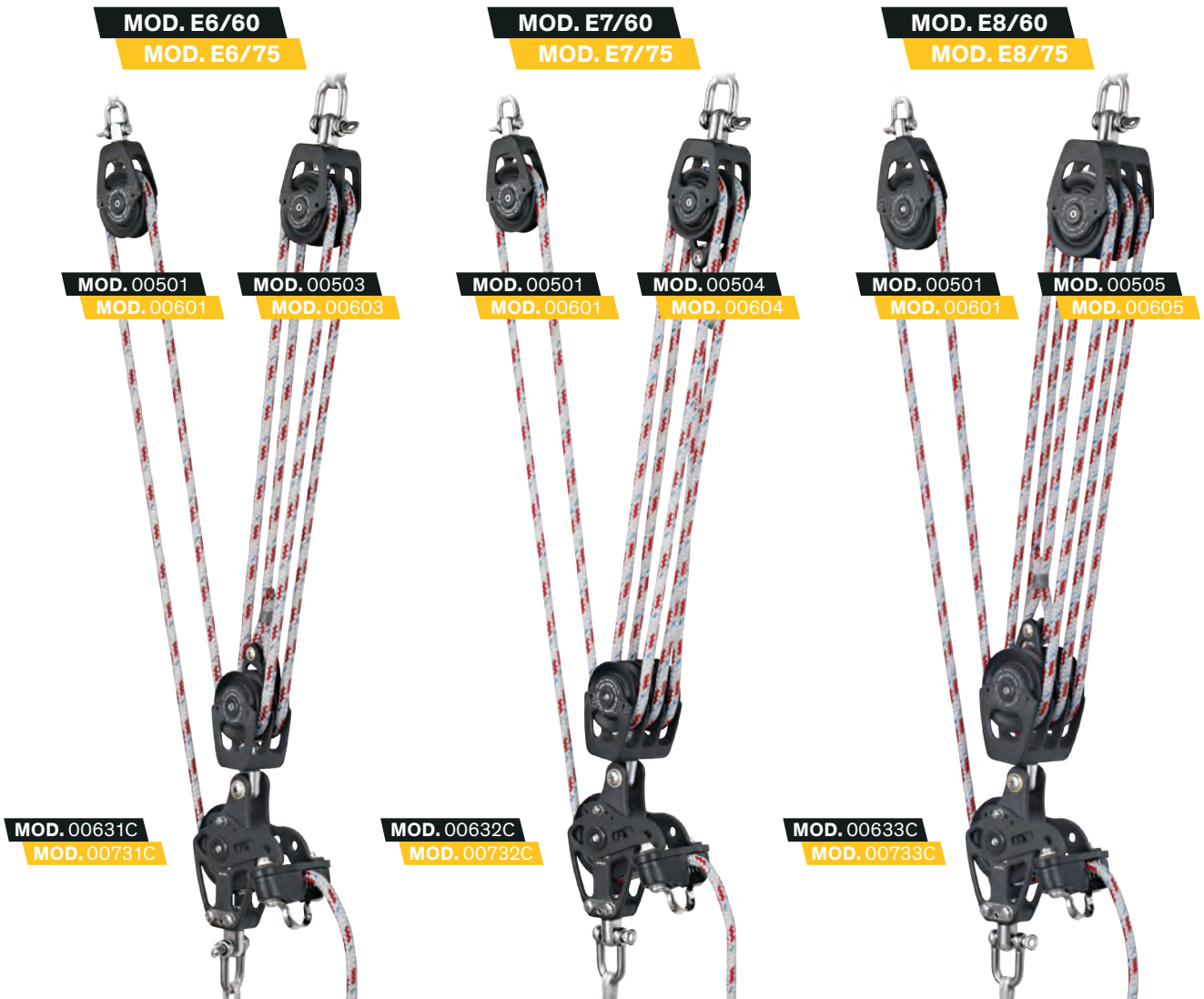

MODEL	E6/60	E6/75	E7/60	E7/75	E8/60	E8/75
POWER	6:1		7:1		8:1	
SWL kg	800	1000	800	1000	800	1000
PRIMARY SHEAVE \varnothing mm	60	75	60	75	60	75
SECONDARY SHEAVE \varnothing mm	50	60	50	60	50	60

All sheaves are made of HRM resin with 2 races of ball bearings.

TWO SPEED MAINSHEET TACKLE: 4/8, 4/12 AND 6/18

The particular configuration adopted permits the use of large diameter sheaves which **improve performance** of the system; it also ensures maximum block orientation capabilities and therefore the possibility to **operate on both sides of the boat**.

Furthermore, this reduces the necessary sheet length. The two speeds are controlled by means of **two independent lines**. Use 10 mm line for the first speed and 6 mm line for the second speed.

FOR BOATS UP TO 36 ft

FOR BOATS UP TO 36 ft

FOR BOATS UP TO 40 ft

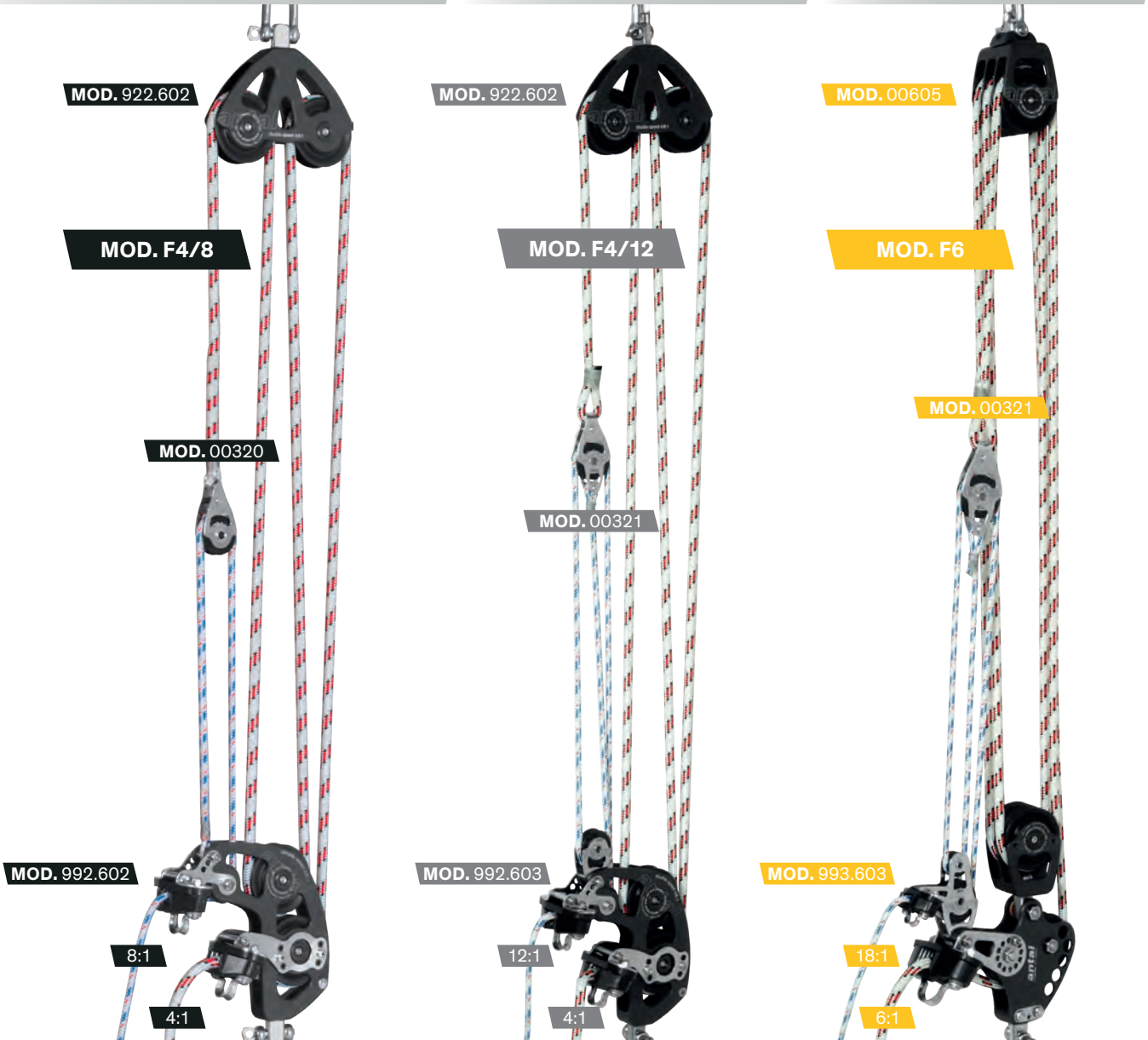

MODEL	F4/8	F4/12	F6
1 st SPEED	4:1	4:1	6:1
2 nd SPEED	8:1	12:1	18:1
SWL kg	800	800	1000
SHEAVE Ø mm	60	60	60
TOTAL WEIGHT kg	0.88	0.92	1.54

All sheaves are made of HRM resin with 2 races of ball bearings.

XXL BLOCKS

SERIES

COMPOSITE FIBRE SERIES

The whole Composite Fibre range uses sheaves on Composite Fibre bearings and double Self Captive Delrin ball thrust bearings. The sheaves are **easy to dismantle for cleaning and need no lubrication.**

The sides are made of 3571 TA16 light alloy and are thickly anodized to ensure absolute wear-and corrosion proofing, with all the edges smoothed off for better handling.

The nuts and bolts have been replaced with recessed screws and pins, considerably reducing weight and eliminating any projecting parts.

The steel coupling revolves on a fibre washer and can easily be locked in one of two main positions.



↓ HIGH STRENGTH ALUMINIUM SHEAVES

Sizes 150, 180, 220 and 250 mm use thickly anodized aluminium sheaves. The main bearing is made of high-strength Composite Fibre impregnated with self-lubricating substances. A double lateral Del-

rin ball bearing makes the sheaves slide perfectly smoothly. Sheaves are supplied with the S.Steel central hub, they are available separately.



Vismara, VM50 Twin

SHEAVE MODEL	D ₁ mm	T mm	MATERIAL	D ₂ mm	D ₃ mm	D ₄ mm	SWL kg	WEIGHT kg
15029A	150	29	aluminium	40	34	20	6500	0.8
18035A	180	35	aluminium	50	40	24	9000	1.40
21843A	220	43	aluminium	50	34	33	13000	2.59
24852A	250	52	aluminium	75	48	40	20000	4.4
24856A	250	56	aluminium	65	48	40	20000	4.8
30059A	300	59	aluminium	85	65	44	30000	6.7

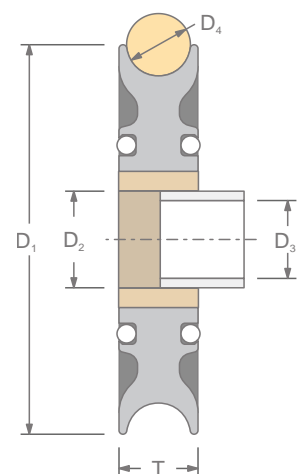



MOD. 911.154

SINGLE BLOCK
WEIGHT – 1.80 kg
SWL – 6500 kg • HR SHACKLE – 14 mm



MOD. 941.154

BLOCK WITH BECKET
WEIGHT – 2.00 kg
SWL – 6500 kg • HR SHACKLE – 14 mm



MOD. 981.154

FIDDLE WITH BECKET
WEIGHT – 2.80 kg
SWL – 6500 kg • HR SHACKLE – 14 mm



MOD. 910.155Z

WEB BLOCK • STRENGTHNED
WEIGHT – 1.90 kg
SWL – 8000 kg • For line connection



MOD. 940.155Z

WEB WITH BECKET • STRENGTHNED
WEIGHT – 2.02 kg
SWL – 8000 kg • For line connection



→ **MOD. 7216** (page 204)

MOD. 812.154

BLOCK ON PAD-EYE
WEIGHT – 3.10 kg • **SWL – 6500 kg**
SCREWS – 6xØ10 mm (not included)



→ **MOD. 7316** (page 205)

MOD. 813.154

BLOCK ON SCREWED PAD-EYE
WEIGHT – 4.10 kg • **SWL – 6500 kg**
SCREWS – 6xØ10 mm (not included)

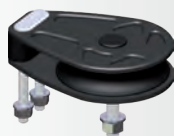

MOD. 831.154

DECK BLOCK
WEIGHT – 1.40 kg • **SWL – 6500 kg**
SCREWS – 2xØ10 + 2xØ12 + 1xØ14 mm
(included)

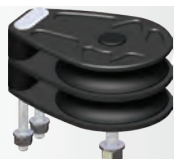

MOD. 832.154

DOUBLE DECK BLOCK
WEIGHT – 2.30 kg • **SWL – 6500 kg**
SCREWS – 2xØ10 + 2xØ12 + 1xØ14 mm
(included)



Full scale pic (MOD. 911.154) →

XXL 180

180 mm SHEAVE for 24 mm LINE – SAFE WORKING LOAD = 9000 kg



MOD. 911.184

SINGLE BLOCK
WEIGHT – 2.85 kg
SWL – 9000 kg • HR SHACKLE – 16 mm



→ **MOD. 7220** (page 204)

MOD. 812.184

BLOCK ON PAD-EYE
WEIGHT – 5.25 kg • SWL – 9000 kg
SCREWS – 6×Ø10 mm (not included)



MOD. 941.184

BLOCK WITH BECKET
WEIGHT – 3.20 kg
SWL – 9000 kg • HR SHACKLE – 16 mm



→ **MOD. 7321** (page 205)

MOD. 813.184

BLOCK ON SCREWED PAD-EYE
WEIGHT – 6.60 kg • SWL – 9000 kg
SCREWS – 6×Ø10 mm (not included)



MOD. 910.185

WEB BLOCK
WEIGHT – 2.60 kg
SWL – 9000 kg • For line connection

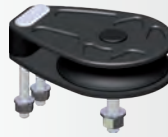

MOD. 831.184

DECK BLOCK
WEIGHT – 2.30 kg • SWL – 9000 kg
SCREWS – 3×Ø10 + 2×Ø14 + 1×Ø16 mm
(included)



MOD. 940.185

WEB WITH BECKET
WEIGHT – 2.70 kg
SWL – 9000 kg • For line connection

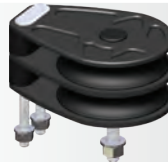

MOD. 832.184

DOUBLE DECK BLOCK
WEIGHT – 3.65 kg • SWL – 9000 kg
SCREWS – 3×Ø10 + 2×Ø14 + 1×Ø16 mm
(included)

XXL 220

220 mm SHEAVE for 30 mm LINE – SAFE WORKING LOAD = 13000 kg



MOD. 911.224

SINGLE BLOCK
WEIGHT – 9.60 kg
SWL – 13000 kg • HR SHACKLE – 20 mm

NEW



MOD. 950.224

BLOCK ON PAD-EYE
WEIGHT – 11.1 kg
SWL – 13000 kg



MOD. 941.224

BLOCK WITH BECKET
WEIGHT – 10.20 kg
SWL – 13000 kg • HR SHACKLE – 20 mm



MOD. 910.225

WEB BLOCK
WEIGHT – 7.65 kg
SWL – 13000 kg • For line connection



MOD. 940.225

WEB WITH BECKET
WEIGHT – 8.25 kg
SWL – 13000 kg • For line connection



Contact us for any other custom requests regarding sizes or uses. Full scale pic (MOD. 911.184) →

XXL 250

250 mm SHEAVE for 40 mm LINE – SAFE WORKING LOAD = 20000 kg



MOD. 911.254

SINGLE BLOCK
WEIGHT – 14.35 kg
SWL – 20000 kg • HR SHACKLE – 24 mm

NEW



MOD. 950.254

BLOCK ON PAD-EYE
WEIGHT – 19.1 kg
SWL – 20000 kg



MOD. 941.254

BLOCK WITH BECKET
WEIGHT – 15.05 kg
SWL – 20000 kg • HR SHACKLE – 24 mm



MOD. 910.255

WEB BLOCK
WEIGHT – 10.35 kg
SWL – 20000 kg • For line connection



MOD. 940.255

WEB WITH BECKET
WEIGHT – 11.05 kg
SWL – 20000 kg • For line connection



XXL 300

300 mm SHEAVE for 40 mm LINE – SAFE WORKING LOAD = 30000 kg

NEW



MOD. 911.304

SINGLE BLOCK
WEIGHT – 17.2 kg
SWL – 30000 kg

NEW



MOD. 950.304

BLOCK ON PAD-EYE
WEIGHT – 34.6 kg
SWL – 30000 kg

NEW



MOD. 941.304

BLOCK WITH BECKET
WEIGHT – 18 kg
SWL – 30000 kg

NEW



MOD. 910.304

WEB BLOCK
WEIGHT – 16.6 kg
SWL – 40000 kg • For line connection



NEW



MOD. 940.304

WEB WITH BECKET
WEIGHT – 17.2 kg
SWL – 40000 kg • For line connection



MEGA BLOCK FOR RUNNERS

CUSTOM, ON REQUEST

SHEAVE Ø – 450 mm
LINE Ø – 30 mm
WEIGHT – 32 kg
SWL – 52 TON

Composite Fibre main bearing, 2 side Torton ball bearing.

Full scale pic (MOD. 911.254) →

All XXL models can be supplied in S.Steel.

LOOPER

SERIES

LOOPER is an ultralight one-piece-frame block provided with a **Dyneema™ snap-loop** for fast, easy and safe connections.

CHARACTERISTICS

Hard black anodized one-piece-aluminium frame, resin sheave on Composite Fibre bushing and double side ball bearings, plus a Dyneema™ snap-loop.

THE "ONE PIECE FRAME"

The one-piece aluminium extruded body is the **strongest and lightest solution**, no assembling pin rivets or screws and nuts. CNC machined, polished, hard black anodized and teflon coated.

THE "COMPOSITE FIBRE" SHEAVE

The resin (aluminium on larger mod) sheave runs on the main Composite Fibre bearing and on a ground S.Steel hub: low friction, high-loads and no lubricant required. The **self-captive side ball bearing** reduces the friction and makes **disassembling, cleaning and maintenance very easy**. Sheaves are supplied with the S.Steel hub, they are available separately.



DYNEEMA™ PAD-EYE
Special eye-strap designed for Dyneema™ Loop, aluminium made, hard black anodizing.

For more info see page 188.



Blocks on sizes **70-80-100** are available in the **roller version**. To order this version, add **R** at the beginning of the code (e.g., **MOD. RLS1070**). For more information, see page 102.

For a "tied looper" the block without snap-loop is also available, the line is not included.

For this version without snap-loop replace **LS** with **LL** in the model number.

E.g.
MOD. LS1080 is the 80 mm Looper with snap-loop,
MOD. LL1080 is the same without snap-loop.

SNAP-LOOP AND DOG-BONE FASTENINGS

Dyneema™ snap-loops including "Dog-Bone" aluminium fastenings are available. Dog-Bone fastenings are also available separately so that Loops of any length can be prepared.

SNAP-LOOP

These snap-loops are obtained with a spliced Dyneema™ line without cover and an aluminium dog-bone.

MODEL	DYNEEMA™ Ø mm	BL kg	SWL* kg	L mm	WEIGHT g
LS2060	4	3000	1000	100	11
LS2070	5	5200	1600	110	20
LS2080	6	6600	2200	125	44
LS2100	8	11000	3500	160	81

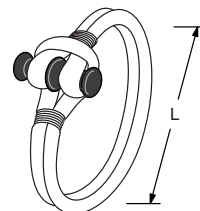

DOG-BONE

You can prepare your special snap-loop using Antal aluminium dog-bones, separately available.

MODEL	FOR DYNEEMA™ Ø mm	Ø mm	L mm	WEIGHT g
LS2062	4	6.5	30	3
LS2072	5	8.0	37	6
LS2082	6	10.0	46	13
LS2102	8	11.5	55	22
LS2122	10	13.5	67	36
LS2142	12	16.0	79	55



LOOPER

SERIES



SIZE 60

SWL – 1000 kg
SHEAVE Ø – 60 mm
LINE Ø – 10 mm



MOD. LS2060

DYNEEMA™ LOOP 4 mm
WEIGHT – 11 g



MOD. LS1060

SIMPLE
WEIGHT* – 106 g



MOD. LS1062

DOUBLE
WEIGHT* – 196 g



MOD. LS1061

SIMPLE BECKET
WEIGHT* – 116 g



MOD. LS1063

DOUBLE BECKET
WEIGHT* – 206 g

SIZE 70

SWL – 1600 kg
SHEAVE Ø – 70 mm
LINE Ø – 12 mm



MOD. LS2070

DYNEEMA™ LOOP 5 mm
WEIGHT – 20 g



MOD. LS1070

SIMPLE
WEIGHT* – 155 g



MOD. LS1072

DOUBLE
WEIGHT* – 285 g



MOD. LS1071

SIMPLE BECKET
WEIGHT* – 172 g



MOD. LS1073

DOUBLE BECKET
WEIGHT* – 302 g

SIZE 80

SWL – 2200 kg
SHEAVE Ø – 80 mm
LINE Ø – 14 mm



MOD. LS2080

DYNEEMA™ LOOP 6 mm
WEIGHT – 44 g



MOD. LS1080

SIMPLE
WEIGHT* – 268 g



MOD. LS1082

DOUBLE
WEIGHT* – 490 g



MOD. LS1081

SIMPLE BECKET
WEIGHT* – 290 g



MOD. LS1083

DOUBLE BECKET
WEIGHT* – 510 g

* Dyneema™ loop included.

SIZE 100

SWL – 3500 kg
SHEAVE Ø – 100 mm
LINE Ø – 16 mm



MOD. LS2100

DYNEEMA™ LOOP 8 mm
WEIGHT – 81 g



MOD. LS1100

SIMPLE
WEIGHT* – 438 g



MOD. LS1101

SIMPLE BECKET
WEIGHT* – 473 g

SIZE 120

SWL – 6000 kg
SHEAVE Ø – 120 mm
LINE Ø – 18 mm



MOD. LS2121

DYNEEMA™ LOOP 10 mm
WITH COVER
WEIGHT – 150 g



MOD. LS1120

SIMPLE
WEIGHT* – 890 g



MOD. LS1121

SIMPLE BECKET
WEIGHT* – 925 g

SIZE 140

SWL – 8000 kg
SHEAVE Ø – 140 mm
LINE Ø – 20 mm



MOD. LS2141

DYNEEMA™ LOOP 12 mm
WITH COVER
WEIGHT – 219 g



MOD. LS1140

SIMPLE
WEIGHT* – 1129 g



MOD. LS1141

SIMPLE BECKET
WEIGHT* – 1179 g

* Dyneema™ loop included.

Blocks on sizes **70-80-100** are available in the **roller version**. To order this version, add **R** at the beginning of the code (e.g., **MOD. RLS1070**). For more information, see page 102.

A316 S.STEEL

SERIES

CLASSIC LINE

This stainless steel series, with a traditional design, is conceived especially for classic boats. The line includes 6 different sizes with diameters from 65 to 180 mm and Safe Working Load up to 9000 kg.

Perfectly polished **A316 stainless steel** cheek-plates and accessories, fully rounded corners for **greater manageability**, nuts and bolts replaced by pins and recessed screws to eliminate any protruding parts.

Each size is available in numerous versions as described in the following pages.



CAM CLEAT



All models can be supplied with cam cleat. Just add **C** to the model code when ordering.

SHEAVES



Resin or aluminium sheaves (in larger models) are easy to dismantle and work on a main Composite Fibre bearing and two side ball bearings (self-captive).

Atena – Blitz Exclusive





MOD. S0601

SINGLE BLOCK with swivel head
WEIGHT – 0.29 kg
SWL – 800 kg • SHACKLE* – 6 mm



MOD. S0602

SINGLE WITH BECKET and swivel head
WEIGHT – 0.32 kg
SWL – 800 kg • SHACKLE* – 6 mm



MOD. S0603

DOUBLE BLOCK with fixed head
WEIGHT – 0.51 kg
SWL – 1200 kg • SHACKLE* – 8 mm



MOD. S0604

DOUBLE WITH BECKET and fixed head
WEIGHT – 0.54 kg
SWL – 1200 kg • SHACKLE* – 8 mm



MOD. S0605

TRIPLE BLOCK with fixed head
WEIGHT – 0.70 kg
SWL – 1200 kg • SHACKLE* – 8 mm



MOD. S0606

TRIPLE WITH BECKET and fixed head
WEIGHT – 0.73 kg
SWL – 1200 kg • SHACKLE* – 8 mm



MOD. S0611

DECK BLOCK
WEIGHT – 0.30 kg • **SWL – 800 kg**
SCREWS – 2xØ8 mm (included)



MOD. S0609

WEBBING BLOCK
WEIGHT – 0.25 kg
SWL – 800 kg • For line connection



MOD. S0612

DOUBLE DECK BLOCK
WEIGHT – 0.46 kg • **SWL – 800 kg**
SCREWS – 2xØ8 mm (included)



→ **MOD. 7106** (page 207)

MOD. S0613

BLOCK ON U-BOLT
WEIGHT – 0.36 kg • **SWL – 800 kg**
SCREWS – 2xØ6 mm (included)



→ **MOD. 7206** (page 204)

MOD. S0614

BLOCK ON PAD-EYE
WEIGHT – 0.38 kg • **SWL – 800 kg**
SCREWS – 2xØ6 mm (included)



→ **MOD. 7306** (page 205)

MOD. S0615

BLOCK ON SCREWED PAD-EYE
WEIGHT – 0.45 kg • **SWL – 800 kg**
SCREWS – 2xØ6 mm (included)



MOD. S0616

STAND-UP BLOCK
WEIGHT – 0.37 kg • **SWL – 800 kg**
SCREWS – 1xØ12 mm (included)

Full scale pic →

* Shackle **not** included.



CAM CLEAT

WEIGHT +0.18 g
MAX LOAD – 160 kg

All models are available with cam-cleat, add **C** to the model code.



MOD. S0701

SINGLE BLOCK with swivel head
WEIGHT – 0.39 kg
SWL – 1500 kg • SHACKLE* – 8 mm



MOD. S0702

SINGLE WITH BECKET and swivel head
WEIGHT – 0.46 kg
SWL – 1500 kg • SHACKLE* – 8 mm



MOD. S0703

DOUBLE BLOCK with fixed head
WEIGHT – 0.68 kg
SWL – 2300 kg • SHACKLE* – 10 mm



MOD. S0704

DOUBLE WITH BECKET with fixed head
WEIGHT – 0.75 kg
SWL – 2300 kg • SHACKLE* – 10 mm



MOD. S0705

TRIPLE BLOCK with fixed head
WEIGHT – 0.91 kg
SWL – 2300 kg • SHACKLE* – 10 mm



MOD. S0706

TRIPLE WITH BECKET with fixed head
WEIGHT – 0.98 kg
SWL – 2300 kg • SHACKLE* – 10 mm



→ **MOD. 7208** (page 204)

MOD. S0714

BLOCK ON PAD-EYE
WEIGHT – 0.65 kg • **SWL – 1500 kg**
SCREWS – 4xØ6 mm (included)



→ **MOD. 7308** (page 205)

MOD. S0715

BLOCK ON SCREWED PAD-EYE
WEIGHT – 0.95 kg • **SWL – 1500 kg**
SCREWS – 4xØ6 mm (included)

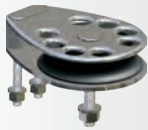

MOD. S0711

DECK BLOCK
WEIGHT – 0.35 kg • **SWL – 1500 kg**
SCREWS – 2xØ6 + 1xØ10 mm (included)



→ **MOD. 7108** (page 207)

MOD. S0713

BLOCK ON U-BOLT
WEIGHT – 0.55 kg • **SWL – 1500 kg**
SCREWS – 2xØ8 mm (included)



MOD. S0712

DOUBLE DECK BLOCK
WEIGHT – 0.62 kg • **SWL – 1500 kg**
SCREWS – 2xØ6 + 1xØ10 mm (included)



MOD. S0731

CLASSIC DECK BLOCK
WEIGHT – 0.86 kg • **SWL – 1500 kg**
SCREWS – 4xØ8 mm (included)



MOD. S0732

CLASSIC DOUBLE DECK BLOCK
WEIGHT – 1.32 kg • **SWL – 1500 kg**
SCREWS – 4xØ8 mm (included)



Full scale pic →

* Shackle **not** included.



RUNNER'S EYEBOLT
Deck blocks are available with runner's eyebolt, add **V** to the model code.



CAM CLEAT
WEIGHT +0.18 g
MAX LOAD – 160 kg
All models are available with cam-cleat, add **C** to the model code.



MOD. S0901

SINGLE BLOCK with swivel head
WEIGHT – 0.73 kg
SWL – 2500 kg • SHACKLE* – 10 mm



MOD. S0902

SINGLE WITH BECKET and swivel head
WEIGHT – 0.85 kg
SWL – 2500 kg • SHACKLE* – 10 mm



MOD. S0903

DOUBLE BLOCK with fixed head
WEIGHT – 1.13 kg
SWL – 3300 kg • SHACKLE* – 12 mm



MOD. S0904

DOUBLE WITH BECKET with fixed head
WEIGHT – 1.25 kg
SWL – 3300 kg • SHACKLE* – 12 mm



MOD. S0905

TRIPLE BLOCK with fixed head
WEIGHT – 1.70 kg
SWL – 3300 kg • SHACKLE* – 12 mm



MOD. S0906

TRIPLE WITH BECKET with fixed head
WEIGHT – 1.83 kg
SWL – 3300 kg • SHACKLE* – 12 mm



→ **MOD. 7210** (page 204)

MOD. S0914

BLOCK ON PAD-EYE
WEIGHT – 1.05 kg • **SWL – 2500 kg**
SCREWS – 4xØ8 mm (included)



→ **MOD. 7310** (page 205)

MOD. S0915

BLOCK ON SCREWED PAD-EYE
WEIGHT – 1.33 kg • **SWL – 2500 kg**
SCREWS – 4xØ8 mm (included)

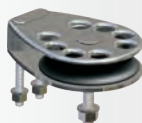

MOD. S0911

DECK BLOCK
WEIGHT – 0.70 kg • **SWL – 2500 kg**
SCREWS – 2xØ8 + 1xØ10 mm (included)

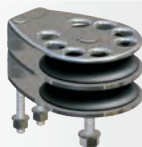

MOD. S0912

DOUBLE DECK BLOCK
WEIGHT – 1.18 kg • **SWL – 2500 kg**
SCREWS – 2xØ8 + 1xØ10 mm (included)



MOD. S0931

CLASSIC DECK BLOCK
WEIGHT – 1.40 kg • **SWL – 2500 kg**
SCREWS – 4xØ8 mm (included)



MOD. S0932

CLASSIC DOUBLE DECK BLOCK
WEIGHT – 2.18 kg • **SWL – 2500 kg**
SCREWS – 4xØ8 mm (included)



RUNNER'S EYEBOLT

Deck blocks are available with runner's eyebolt, add **V** to the model code.



Full scale pic →

* Shackle **not** included.



MOD. S1201

SINGLE BLOCK with swivel head
WEIGHT – 1.28 kg
SWL – 4500 kg • HR SHACKLE* – 12 mm



MOD. S1202

SINGLE WITH BECKET and swivel head
WEIGHT – 1.46 kg
SWL – 4500 kg • HR SHACKLE* – 12 mm



MOD. S1203

DOUBLE BLOCK with fixed head
WEIGHT – 1.95 kg
SWL – 6000 kg • HR SHACKLE* – 14 mm



MOD. S1204

DOUBLE WITH BECKET with fixed head
WEIGHT – 2.13 kg
SWL – 6000 kg • HR SHACKLE* – 14 mm



→ **MOD. 7214** (page 204)

MOD. S1214

BLOCK ON PAD-EYE
WEIGHT – 2.28 kg • **SWL – 4500 kg**
SCREWS – 4xØ10 mm (included)



→ **MOD. 7314** (page 205)

MOD. S1215

BLOCK ON SCREWED PAD-EYE
WEIGHT – 2.58 kg • **SWL – 4500 kg**
SCREWS – 4xØ10 mm (included)



MOD. S1211

DECK BLOCK
WEIGHT – 1.13 kg • **SWL – 4500 kg**
SCREWS – 2xØ10 + 1xØ12 mm (included)



MOD. S1212

DOUBLE DECK BLOCK
WEIGHT – 1.74 kg • **SWL – 4500 kg**
SCREWS – 2xØ10 + 1xØ12 mm (included)



MOD. S1231

CLASSIC DECK BLOCK
WEIGHT – 2.15 kg • **SWL – 4500 kg**
SCREWS – 4xØ10 mm (included)



MOD. S1232

CLASSIC DOUBLE DECK BLOCK
WEIGHT – 3.70 kg • **SWL – 4500 kg**
SCREWS – 4xØ10 mm (included)



RUNNER'S EYEBOLT
Deck blocks are available with runner's eyebolt, add **V** to the model code.



Full scale pic →
* Shackle **not** included.



MOD. S1501

SINGLE BLOCK with swivel head
WEIGHT – 2.74 kg
SWL – 6500 kg • HR SHACKLE* – 14 mm



MOD. S1502

SINGLE WITH BECKET and swivel head
WEIGHT – 3.04 kg
SWL – 6500 kg • HR SHACKLE* – 14 mm



→ **MOD. 7210** (page 204)

MOD. S1514

BLOCK ON PAD-EYE
WEIGHT – 4.71 kg • **SWL – 6500 kg**
SCREWS – 6xØ10 mm (included)



→ **MOD. 7316** (page 205)

MOD. S1515

BLOCK ON SCREWED PAD-EYE
WEIGHT – 6.24 kg • **SWL – 6500 kg**
SCREWS – 6xØ10 mm (included)



MOD. S1511

DECK BLOCK
WEIGHT – 2.13 kg • **SWL – 6500 kg**
SCREWS – 2xØ12 + 1xØ14 mm (included)



MOD. S1512

DOUBLE DECK BLOCK
WEIGHT – 3.50 kg • **SWL – 6500 kg**
SCREWS – 2xØ12 + 1xØ14 mm (included)



MOD. S1531

CLASSIC DECK BLOCK
WEIGHT – 4.57 kg • **SWL – 6500 kg**
SCREWS – 4xØ12 mm (included)



MOD. S1532

CLASSIC DOUBLE DECK BLOCK
WEIGHT – 7.91 kg • **SWL – 6500 kg**
SCREWS – 4xØ12 mm (included)



RUNNER'S EYEBOLT
Deck blocks are available with runner's eyebolt, add **V** to the model code.



Full scale pic →

* Shackle **not** included.



MOD. S1801

SINGLE BLOCK with swivel head
WEIGHT – 4.11 kg
SWL – 9000 kg • HR SHACKLE* – 16 mm



MOD. S1802

SINGLE WITH BECKET and swivel head
WEIGHT – 4.61 kg
SWL – 9000 kg • HR SHACKLE* – 16 mm



→ **MOD. 7220** (page 204)

MOD. S1814

BLOCK ON PAD-EYE
WEIGHT – 7.57 kg • **SWL – 9000 kg**
SCREWS – 6xØ10 mm (included)



→ **MOD. 7321** (page 205)

MOD. S1815

BLOCK ON SCREWED PAD-EYE
WEIGHT – 9.51 kg • **SWL – 9000 kg**
SCREWS – 6xØ10 mm (included)



MOD. S1811

DECK BLOCK
WEIGHT – 3.31 kg • **SWL – 9000 kg**
SCREWS – 2xØ14 + 1xØ16 mm (included)



MOD. S1812

DOUBLE DECK BLOCK
WEIGHT – 5.26 kg • **SWL – 9000 kg**
SCREWS – 2xØ14 + 1xØ16 mm (included)



MOD. S1831

CLASSIC DECK BLOCK
WEIGHT – 6.86 kg • **SWL – 9000 kg**
SCREWS – 4xØ14 mm (included)



MOD. S1832

CLASSIC DOUBLE DECK BLOCK
WEIGHT – 11.8 kg • **SWL – 9000 kg**
SCREWS – 4xØ14 mm (included)



RUNNER'S EYEBOLT

Deck blocks are available with runner's eyebolt, add **V** to the model code.

Full scale pic →

* Shackle **not** included.



HALYARD BLOCKS

HALYARD BLOCKS

This solution, designed for halyards at the base of the mast, keeps the line as close to the deck as possible. A316 S.Steel base. All these models are fitted with a "self-captive" double side ball bearings.

Mounting screws **not included**.

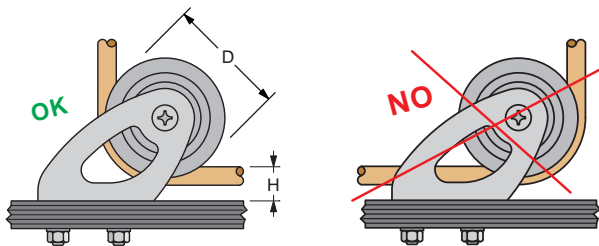

MODEL	Ø LINE mm	D mm	H mm	SWL kg	WEIGHT kg	BOLTS N x Ø mm
815.452	10	45	14	450	0.08	2 x Ø5
815.552	12	55	16	600	0.12	2 x Ø6
815.652	12	65	18	800	0.17	2 x Ø8
815.075	14	75	22	1500	0.26	2 x Ø8
815.090	16	90	24	2500	0.39	2 x Ø10
815.120	18	120	32	4500	1.20	4 x Ø10
815.150	20	150	41	6500	3.30	4 x Ø12
815.180	24	180	51	9000	4.70	4 x Ø16



A316 CUSTOM PRODUCTS

Custom S.Steel products are available on request.

MAXI BLOCK Ø – 300 mm
WORKING LOAD – 30.000 kg
 WEIGHT – 48,50 kg

Custom made for Perini Navi.



HOLLOW PIN DECK-BLOCKS

HOLLOW PIN DECK BLOCK 75, 90, 120 mm

The sheave rotates on a hollow pin with the line passing through the pin's centre. This type of arrangement reduces the height of the line off the deck, and the side loads on the block.

The line position and its direction to the winch does not change, even when the sheave is articulated off-centre. Body completely made in polished S.Steel. Sheave on Composite Fibre bearing and two side ball bearing.

Mounting screws, nuts and washers are **included**.



MODEL	Ø LINE mm	D mm	H mm	L mm	B mm	SWL kg	WEIGHT* kg	BOLTS N x Ø mm
816.075	12	75	20	132	60	1500	0.62	4 x Ø8
816.090	14	90	24	157	66	2500	1.15	4 x Ø10
816.120	18	120	32	194.7	80	4500	1.95	4 x Ø12

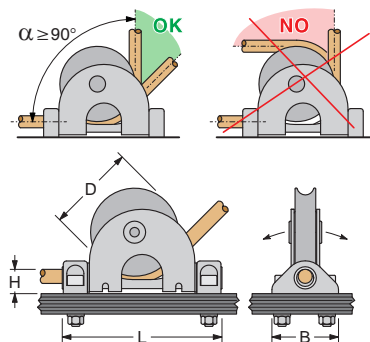

Comar Yacht, Genesis 43 – Ph. E. Fonda

HOLLOW PIN DECK BLOCK 150, 180 mm

The larger models with 150 and 180 mm sheaves are equipped with a double base, where each base is fixed with 4 screws.

Mounting screws, nuts and washers are **included**.



MODEL	Ø LINE mm	D mm	H mm	L mm	B mm	SWL kg	WEIGHT* kg	BOLTS N x Ø mm
816.150	20	150	30	315	94	6500	5.70	8 x Ø10
816.180	22	180	33	373	108	9000	8.70	8 x Ø12

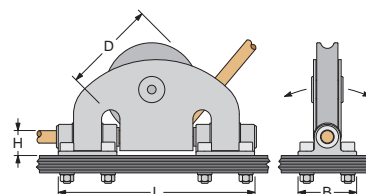

OPF HOLLOW PIN BLOCKS

HOLLOW PIN DECK BLOCK 60, 80, 100 mm

The sheave rotates on a hollow pin with the line passing through the pin's centre. This type of arrangement reduces the height of the line off the deck, and the side loads on the block. The line position and its direction to the winch does not change, even when the sheave is articulated off-centre.

Body completely made in hard black anodized aluminium. Sheave on Composite Fibre bearing and two side ball bearing. Insulating washer under the fixing screws.

Mounting screws, nuts and washers are **included**.



MOD. 00821

MODEL	Ø LINE mm	D mm	H mm	L mm	C mm	SWL kg	WEIGHT* kg	BOLTS N x Ø mm
00621	12	60	19	121	57	1300	0.28	4 x Ø6
00821	14	80	25	160	68	2200	0.49	4 x Ø8
01021	16	100	29	196	79	3500	0.84	4 x Ø10
01021D**	16	100	130	196	135	3500	2.8	6 x Ø10

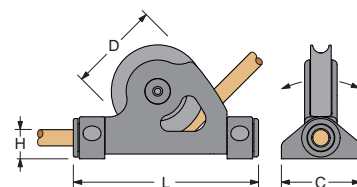

HOLLOW PIN DECK BLOCK WITH CAM-CLEAT

The smallest model with 60 mm sheave is also available with a Cam-Cleat, adjustable to three positions. Mounting screws, nuts and washers are **included**.

MODEL	Ø LINE mm	D mm	H mm	L mm	C mm	SWL kg	WEIGHT* kg	BOLTS N x Ø mm
00621C	12	60	19	121	57	1300***	0.39	4 x Ø6

* Without screws.

** In model code, **D** stands for **double**.

*** Max load on Cam-Cleat is 150 kg.



MOD. 00621C

Itacatamarans 14,99



SHB

HALYARD BLOCK

SWIVELLING HALYARD BLOCKS

This special block has been designed to **direct the halyards** from the mast base to the winches.

Compared to the known "hollow pin" models, it offers two advantages:

- the halyard exit is lower (closer to the deck);
- the narrow base allows the assembly of more blocks in the narrow space of the mast base.

There are actually **three sizes** available (see the following tab).

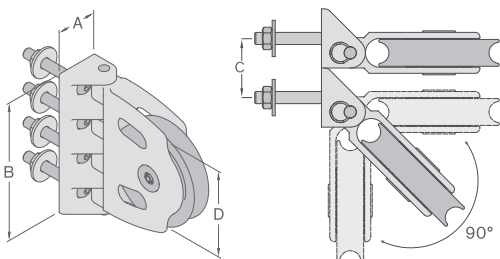

MODEL	00619	00819	01019
SIZE (D) mm	60	80	100
SWL kg	1300	2200	3500
BASE (A x B) mm	35 x 102	40 x 120	45 x 150
SCREWS (N x Ø) mm	2 x Ø8	4 x Ø8	4 x Ø10
WEIGHT* kg	430	530	920
FOR LINE mm	12	14	16
C mm	35	39	45

* Fixing screws are **included**.



MAST BLOCKS

MAST BLOCKS

12 different sizes with diameters from **40 to 140 mm** for working loads (SWL) up to **9000 kg**.

Hard black anodized aluminium frame with insulating washers for corrosion protection. Resin sheaves (aluminium sheaves for 100, 120 and 140 mm only) with Composite Fibre main bearing (not on size 40) and double side self-captive ball bearing.

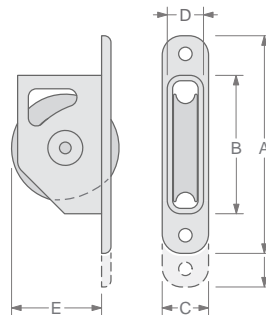

MOD. 00818Z

MODEL	DIA mm	Ø LINE mm	A mm	B mm	C mm	D mm	E mm	SWL* kg	WEIGHT kg	BOLTS N x Ø mm
00418	40	8	107	58	24.2	18.2	31.5	400	0.07	2 x Ø6
00518	50	12	118	69.5	29.5	22.5	37	600	0.12	2 x Ø6
00618	60	12	130	81.5	29.5	22.5	49	800	0.15	2 x Ø6
00718	70	12	140	91.5	29.5	22.5	53.5	1300	0.16	2 x Ø6
00718Z			158					2000	0.23	3 x Ø6
00818	80	14	162	103	34.5	27	62.5	2200	0.24	2 x Ø8
00818Z			187					3000	0.34	3 x Ø8
01018	100	16	198	126	39	31	81.5	3500	0.44	2 x Ø10
01018Z			226					4500	0.62	3 x Ø10
01218	120	18	251	151	47	37	103	5000	0.97	3 x Ø10
01218Z			263					7000	1.08	3 x Ø12
01418Z	140	20	286	174	49	39	120	9000	1.55	3 x Ø12

DUAL SHEAVE MAST BLOCKS

The **Dual Sheave mast block** solves the problem of the wear of the halyards coming out of the mast. This solution is also suitable for running a line from above to below deck.

Two sizes with **34/40 mm** sheaves for **12/16 mm** lines.

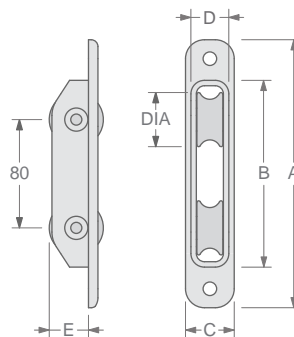

MOD. 00418D

MODEL	DIA mm	Ø LINE mm	A mm	B mm	C mm	D mm	E mm	SWL* kg	WEIGHT kg	BOLTS N x Ø mm
00318D	2 x 34	12	158	110	29	22	24	1500	0.14	2 x Ø6
00418D	2 x 40	16	198	138	36	28	29	2500	0.26	2 x Ø8

* Safe working load for the sheave.

ORGANIZERS

ORGANIZERS (Ø = 40, 50, 60 AND 70 mm)

Groups of 2 to 6 sheaves in **4 diameters** of 40, 50, 60 and 70 mm. The 40 and 50 mm sheaves are manufactured in **high-strength resin** with a double side ball bearing. The 60 and 70 mm sheaves are manufactured in **aluminium**, hard black anodized, with a main Composite Fibre bearing and 2 side ball bearings. Mounting screws, nuts and washers are **included**. These new organizers do not disassemble after tacking off the screws.

Double version also available, just add **D** to the model number.



MOD. D530

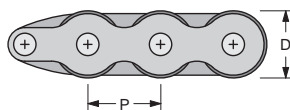

SHEAVE SWL

The maximum Safe Working Load on the single sheave.

ORGANIZER SWL

The maximum Safe Working Load on the organizer.

D mm	Ø LINE mm	N° SHEAVES	MODEL	LENGTH mm	P mm	WEIGHT* kg	SHEAVE SWL kg	ORGANIZER SWL kg	BOLTS N x Ø mm
40	14	2	D420	111	44	0.13	800	800	3 x Ø6
		3	D430	155		0.19		1200	4 x Ø6
		4	D440	199		0.24		1600	5 x Ø6
		5	D450	243		0.30		2000	6 x Ø6
		6	D460	287		0.35		2400	7 x Ø6
50	16	2	D520	133	52	0.20	1200	1200	3 x Ø8
		3	D530	185		0.29		1800	4 x Ø8
		4	D540	237		0.37		2400	5 x Ø8
		5	D550	289		0.46		3000	6 x Ø8
		6	D560	341		0.54		3600	7 x Ø8
60	18	2	D620	163	65	0.48	2200	2200	3 x Ø10
		3	D630	228		0.69		3300	4 x Ø10
		4	D640	293		0.91		4400	5 x Ø10
		5	D650	358		1.13		5500	6 x Ø10
		6	D660	423		1.35		6600	7 x Ø10
		7	D670	488		2.27		7700	8 x Ø10
		8	D680	553		2.58		8800	9 x Ø10
70	20	2	D720	190	76	0.74	3200	3200	3 x Ø12
		3	D730	266		1.07		4800	4 x Ø12
		4	D740	342		1.40		6400	5 x Ø12
		5	D750	418		1.74		8000	6 x Ø12
		6	D760	494		2.07		9600	7 x Ø12

* Weight **without** screws, washers and nuts.

TURNING SHEAVES

Mounted aft of a set of rope clutches, the turning sheave redirects each line to the most suitable winch. Mounting screws, nuts and washers are **included**.

MODEL	D mm	H mm	SWL kg	WEIGHT* kg	BOLTS N x Ø mm
821.052	50	33	800	0.10	1 x Ø10
821.062	60	38	1200	0.18	1 x Ø12
821.074	70	44	1800	0.38	4 x Ø8

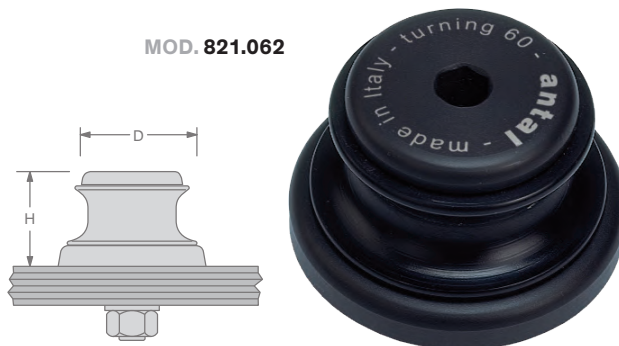

TULIP

SERIES



TULIP SERIES SHEAVES

The Tulip sheaves are fixed sheaves that do not turn in the direction of manoeuvres since they accept quite **different lead angles**. The choice of a Tulip sheave instead of a revolving block comes from the need to **reduce bulk and weight**.

The sheave, with an axial bearing in Composite Fibre and large round bearings (self-captive) in Torton for side loads, is in anodized and Teflon coated aluminium and can handle very high loads.

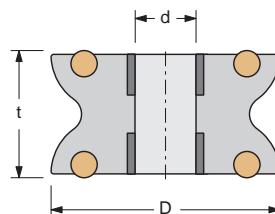

MODEL	D mm	Ø LINE mm	d mm	t mm	SWL kg	WEIGHT kg
801.045*	45	12	12	31	1000	0.04
801.060	60	14	15	38	2200	0.16
801.071	70	14	15	38	3000	0.19
801.073	70	16	20	46	3800	0.26
801.090	90	14	20	50	5000	0.45
801.091	90	14	30	38	5800	0.42
801.092	90	14	30	50	6000	0.48
801.111	110	16	30	60	9000	0.83

* The D = 45 mm sheave is resin made with Delrin side ball bearings.

NEW

TURNING TULIP SHEAVE

This sheave is fitted with 4 wide Torton ball bearings, this is the best solution when it is necessary to redirect the line to any angle.

Mounting screws, nuts and washers are **included**.

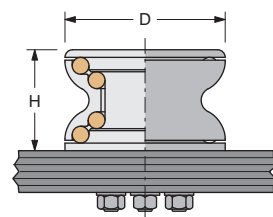

MODEL	D mm	Ø LINE mm	H mm	SWL kg	WEIGHT* kg	SCREWS N x Ø mm
821.050	50	10	40	1000	0.14	1 x Ø10
821.070	70	12	52	1400	0.35	1 x Ø12
821.100	100	14	66	3000	0.90	4 x Ø8

* Weight **without** screws, washers and nuts.

Maxi Dolphin 75, Karma – Ph. F. Ferri

TULIP ORGANIZERS

HORIZONTAL TULIP ORGANIZERS

With Tulip sheaves organizers can also be made. Batteries from 2 to 6 sheaves are available, with diameters **45** and **60** mm. The **45** mm sheaves are in **high resistance resin**, with a "self-captive" double side ball bearing. The **60** mm sheave, with an axial bearing in Composite Fibre and large round bearings (self-captive) in Torton for side loads, is in anodized and Teflon-coated aluminium and can handle very high loads.

Mounting screws, nuts and washers are **included**.



MOD. T540



MOD. T530

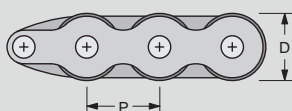

SHEAVE SWL

The maximum Safe Working Load on the single sheave.

ORGANIZER SWL

The maximum Safe Working Load on the organizer.

D mm	Ø LINE mm	N° SHEAVES	MODEL	LENGTH mm	P mm	WEIGHT* kg	SHEAVE SWL kg	ORGANIZER SWL kg	BOLTS N x Ø mm
45	12	2	T520	132	52	0.23	1200	1200	3 x Ø8
		3	T530	184		0.33		1800	4 x Ø8
		4	T540	236		0.42		2400	5 x Ø8
		5	T550	288		0.52		3000	6 x Ø8
		6	T560	340		0.61		3600	7 x Ø8
60	14	2	T620	160	65	0.48	2200	2200	3 x Ø10
		3	T630	225		0.69		3300	4 x Ø10
		4	T640	290		0.91		4400	5 x Ø10
		5	T650	355		1.13		5500	6 x Ø10
		6	T660	420		1.35		6600	7 x Ø10

* Weight **without** screws, washers and nuts.

TULIP FOOTBLOCK

Base and cover in hard black aluminium. Mounting screws, nuts and washers are **included**.

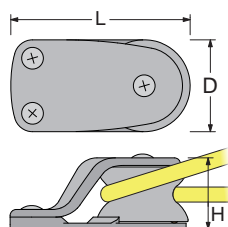

MODEL	D mm	Ø LINE mm	L mm	H mm	SWL kg	WEIGHT* kg	SCREWS N x Ø mm
819.045	45	12	92	42	1000	0.19	1xØ8 + 2xØ6
819.060	60	14	116	51	1600	0.43	1xØ10 + 2xØ8
819.070	70	14	132	51	2200	0.60	1xØ10 + 2xØ8
819.090	90	14	163	63	3000	1.10	1xØ12 + 2xØ10
819.110	110	18	213	89	9000	3.2	4xØ12

* Weight **without** screws, washers and nuts.

NEW

VERTICAL TULIP BLOCKS

VERTICAL TULIP BLOCKS

These vertical blocks are fitted with Tulip sheaves that accept very different lead angles. This is a small and light solution that replaces traditional adjustable blocks. The 60 and 70 are aluminium made with Torlon side ball bearings.

Mounting screws, nuts and washers **included**.



MOD. 817.050 - VERTICAL

MOD. 818.050 - OVERTHE TOP

MODEL	D mm	LINE Ø mm	L / B mm	SWL kg	WEIGHT kg	SCREWS N x Ø mm
↓ VERTICAL						
817.050	45**	12	58.5 / 35	1000	0.16	2 x Ø6
817.060	60	14	74.5 / 44	2200	0.39	3 x Ø8
817.071	70	14	93.5 / 54.5	3000	1.04	3 x Ø10
↓ OVERTHE TOP						
818.050	45**	12	62.3 / 35	1000	0.16	2 x Ø6
818.060	60	14	78.5 / 44	2200	0.39	2 x Ø8
818.071	70	14	92 / 54.5	3000	0.95	2 x Ø10

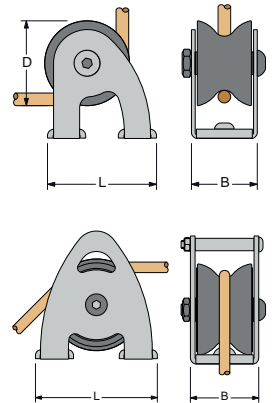

* Weight **without** screws, washers and nuts.

** The D = 45 mm sheave is resin made with Delrin side ball bearings.

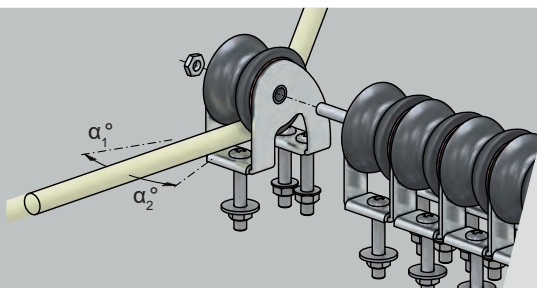

More vertical blocks can be joined to form a set.
For example: for a battery of 5 x MOD. 817.060, just order MOD. 817.060/5.

↓ **Max recommended side deviation**
 $\alpha_1, \alpha_2 = \pm 20^\circ$

MAXI VERTICAL TULIP



MOD. 817.090
 SHEAVE Ø - 90 mm
SWL - 5000 kg
 FASTENERS - 3xØ12 mm
 WEIGHT - 1.40 kg
 LINE MAX Ø - 14 mm
 WIDTH - 67 mm

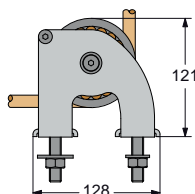

MAXI OVERTHE TOP TULIP



MOD. 818.090
 SHEAVE Ø - 90 mm
SWL - 5000 kg
 FASTENERS - 3xØ12 mm
 WEIGHT - 1.30 kg
 LINE MAX Ø - 14 mm
 WIDTH - 67 mm

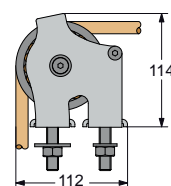

MAINSAIL BLOCKS

CLEW BLOCKS

Solution designed to solve the connection of a sheave to the furling mainsail clew efficiently. The block is contained within the size of the sail, thus allowing a larger surface of the mainsail to be used. The choice of **materials guarantees the least weight** as well as a very good mechanical resistance to the environment. Particular care has been taken over the ease of connection which is obtained by normal "webbing". This ensures moreover a very good distribution of the load on the sail.

MATERIALS – Cheek plates are made of anodized aluminium. Also polished S.Steel solutions are available on request (replace the **AL** part of the code with **S** when ordering the product).



MOD. 991.073

MODEL	Ø LINE mm	D mm	L mm	B mm	SWL kg	WEIGHT kg
991.073AL	14	75	112	3 × 36	1000	0.23
991.093AL	16	90	145	3 × 46	2000	0.45
991.124AL	18	120	190	4 × 46	3000	1.04
991.154AL	20	150	225	4 × 52	4000	2.05
991.184AL	24	180	265	5 × 52	8000	2.65

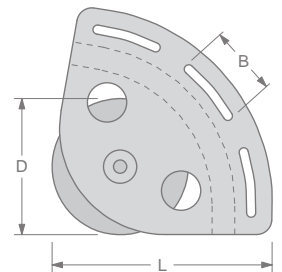

REEF BLOCKS

The blocks are connected to the leech of the mainsail with webbing, and reduce point loading on the mainsail when reefing. The small diameter sheaves are suitable to very **high loads**.

The center hole can be used as a safety connection to the boom when reefed. The small version (D = 50 mm) is for boats to 50 ft, larger (D = 120 mm) for boats to 100 ft.

If a larger sheave is required and if higher weight and larger sizes are acceptable, then the clew blocks described above can be considered.



MOD. 994.075

MODEL	Ø LINE mm	D mm	L mm	B mm	Z mm	SWL kg	WEIGHT kg
994.055	14	50	143	65	20	1500	0.22
994.065	16	60	178	79	20	3000	0.37
994.075	18	70	204	88	25	4500	0.70
994.085	20	80	238	112	35	5500	0.90
994.095	24	100	292	140	45	8000	1.30
994.125	28	120	357	170	60	10000	2.90

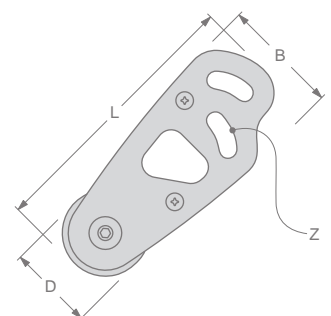

SPECIAL BLOCKS

TWIN HALYARD BLOCKS

The Twin halyard block is specially made for a 2 to 1 main halyard. The very small sheave is aluminium made with a Composite Fibre bushing.

The body is completely made in "High-resistance" S.Steel Nitronic 50. 4 sizes for **breaking loads** from **2600 to 10000 kg**, for boats up to 70 ft.



Self-locking pin

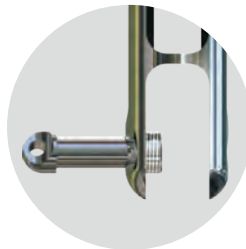

Captive pin



MOD. H030

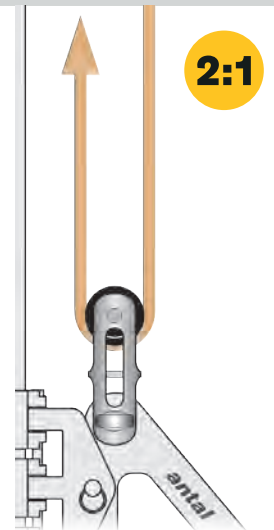

2:1

MODEL	Ø LINE mm	D mm	d mm	A mm	B mm	C mm	SWL kg	WEIGHT kg
H020	8 / 10	28	8	16	15.5	53.5	1300	0.08
H030	10 / 12	34	10	18	20.5	65.0	2200	0.15
H040	12 / 14	42	12	21	24.5	80.0	3500	0.28
H050	14 / 16	49	14	21	34.0	89.0	5000	0.54

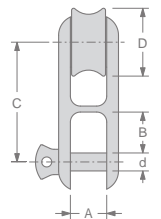

HIGH LOAD BLOCKS

These small and light blocks are the **best solution for very high loads** when sliding is not important.

The very small sheave is fitted with a Composite Fibre bushing. The one piece frame is made for line connection.

The **3 blocks** (D = 30, 40 and 55 mm) give an 8 to 1 system. This system is specially designed for the backstay or the boom-vang.



8:1

Set of blocks, 8:1 system

MOD. H140



MODEL	Ø LINE mm	D mm	H mm	SWL kg	WEIGHT kg
H130	6 / 8	30	59	600	0.05
H140	8 / 10	40	74	1200	0.08
H150	10 / 12	55	91	2400	0.18
H160	12 / 16	70	116	3500	0.33

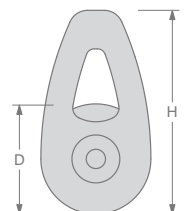

ROLLER BEARING SHEAVES

ROLLER BEARING SHEAVES

In some cases, it is important to reduce the friction of the blocks as much as possible, even if this leads to a reduction in the maximum loads. When compared with the Composite Fibre bushing version, the roller bearing sheaves offer a lower resistance but a greater smoothness.

Antal offers a range of **roller sheaves**, which can replace the traditional sheaves on the OPF series blocks, and a range for the Looper series. The **main characteristics** of these sheaves are described in the following tables.

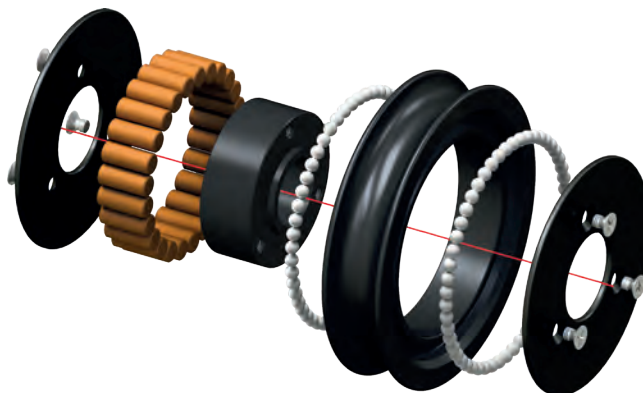

To order OPF or Looper blocks with roller bearing sheaves just add **R** in front of the model code.

FRL is the Free Rolling Load: for good sliding (low friction), the FRL value must not be exceeded.

ML is the Maximum Load: loads higher than the ML cause permanent deformations of the rollers and therefore damage the bearing.

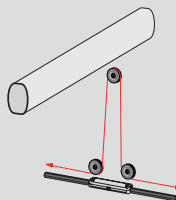

A situation in which it is advisable to consider blocks with roller sheaves is that of the mainsail sheet with a T shape because, in this case, an excessive friction of the blocks makes the car movement very difficult.

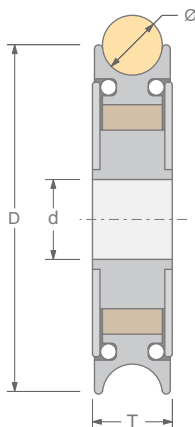

↓ SHEAVES FOR OPF BLOCKS (page 62)

MODEL	D mm	d mm	T mm	Ø mm	WEIGHT g	FRL kg	ML kg
07016R	70	12	16	12	95	1000	1200
08019R	80	16	19	14	160	1600	2000
10021R	100	20	21	16	265	2400	3200

↓ SHEAVES FOR LOOPER BLOCKS (page 80)

MODEL	D mm	d mm	T mm	Ø mm	WEIGHT g	FRL kg	ML kg
07116R	70	16	16	12	90	1000	1200
08119R	80	21	19	14	150	1600	2000
10121R	100	25	21	16	255	2400	3200

Musa 4 – Ph. M. Le Roux



BLOCKS AND SOFT LINKS

BLOCKS AND T-LOCK

Blocks designed to be linked with Dyneema™ loops as Looper Blocks (see page 80) can be tied to a special Antal swivelling toggle and then fitted into the new

Antal T-Lock base (see page 189). The result is a removable deck block that rotates in any direction of the load.



Swivelling toggle



Looper block and toggle



T-Lock base



Swivelling and removable deck block

BLOCKS AND DYNEEMA™ PAD-EYE

An easy and safe way to tie the block down is with multiple wraps of thin Dyneema™ line (E.g. size 3 mm) then splice the two ends and wrap everything with a thin wire (e.g. size 1 mm). Consider that 8 wraps of

well spliced 3 mm Dyneema™ without cover reach a breaking load higher than 6 tons. The link in the picture is obtained with 2.60 m of 3 mm Dyneema™ line and a block size 80 mm (**MOD. LL1080**).



8 wraps



1st spliced end



2nd spliced end



Wrapping

BLOCKS AND SNAP-LOOP

Blocks provided with a Dyneema™ snap-loop as Looper Blocks (page 80) or Snatch Looper (page 108) may be connected to the proper Dyneema™ pad-eye (page 189).



Looper + Dyneema™ Pad-Eye



SnatchLooper + Dyneema™ Pad-Eye

Nautor, Club Swan 50



MINI SNATCH BLOCKS

MINI SNATCH BLOCK (D = 32 mm)

It is a very light solution suitable for many riggings, completely made in U-V resistant high strength resin. It can be fastened both with a line or with a shackle.



Full scale pic →



MOD. 9030B + MOD. 9030Y

MINI SNATCH BLOCK

- For line connection
- Ø SHEAVE – 32 mm
- Ø MAX LINE – 8 mm
- WEIGHT – 39 g
- SWL – 250 kg

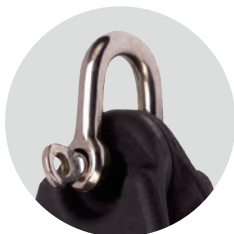

MOD. 9031B + MOD. 9031Y

MINI SNATCH BLOCK

- For 5 mm shackle
- Ø SHEAVE – 32 mm
- Ø MAX LINE – 8 mm
- WEIGHT – 39 g
- SWL – 250 kg

MOD.
9030B
BLACK



MOD.
9030Y
YELLOW

MOD. 9001

SNAP-LOOP

It is a simple and original line loop with a snap that offers an easy fastening and avoids accidental opening.

SWL – 250 kg

For more info, see page 199.



1

OPEN

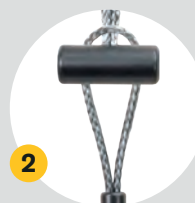

2

CLOSED

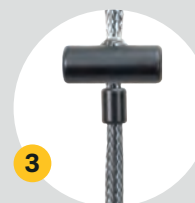

3

LOCKED

Citroen Feel Good, V. Malingri & N. Malingri



DYNABLOCKS

DYNABLOCKS

The new Antal block with revolving resin cheekplates and with a Dyneema™ snap-loop protected by a polyester cover. A light and reliable solution that offers an easy, fast and safe connection. Dynablock is also suitable for a lashing with a thin Dyneema™ line. The resin sheave is on Composite Fibre bushing with two side ball bearings.

Spare snap-loops (**MOD. DBS04** for size 44 and **MOD. DBS05** for size 56) available.



→ With Dyneema™ snap-loop

MODEL	Ø SHEAVE mm	Ø LINE mm	SWL kg	WEIGHT g
DBS44	44	10	600	90
DBS56	56	12	1000	176



→ For lashing (line not included)

MODEL	Ø SHEAVE mm	Ø LINE mm	SWL kg	WEIGHT g
DBL44	44	10	600	80
DBL56	56	12	1000	140

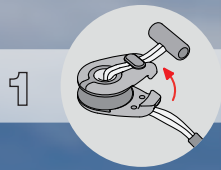

1 Open the block.

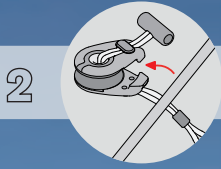

2 Put the line in.

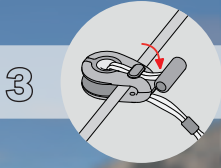

3 Close the block.

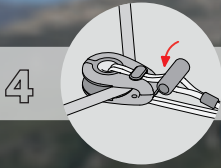

4 Close the loop.

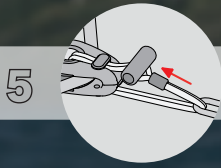

5 Lock the knob.



SNATCH BLOCKS

SNATCH BLOCKS (D = 40 AND 60 mm)

The cheekplate revolves around the **sheave axle** allowing the block to open; a safety ball stops the block from opening with an adjustable screw to set the ball on locked position. There is a becket for the **hanging line**.

MATERIAL – Sheave with Composite Fibre main bearing and double side ball bearing. Hard anodized and teflon coated aluminium cheekplates with side rubber protections (yellow rubber on the revolving cheekplate).



MODEL	D mm	Ø LINE mm	SWL kg	WEIGHT g
9040	40	12	700	110
9060	60	14	1300	260



Standard model can be attached with highly resistant spectra line.



Model **SH** is supplied with a shackle.



Model **SN** is supplied with a snap-shackle (HR).

SNAP-LOOPS

It is a simple and original line loop with a snap that offers an easy fastening and avoids accidental opening.

MOD. SL4S

Loop for 9040 block (page 199).

MOD. SL5S

Loop for 9060 block (page 199).

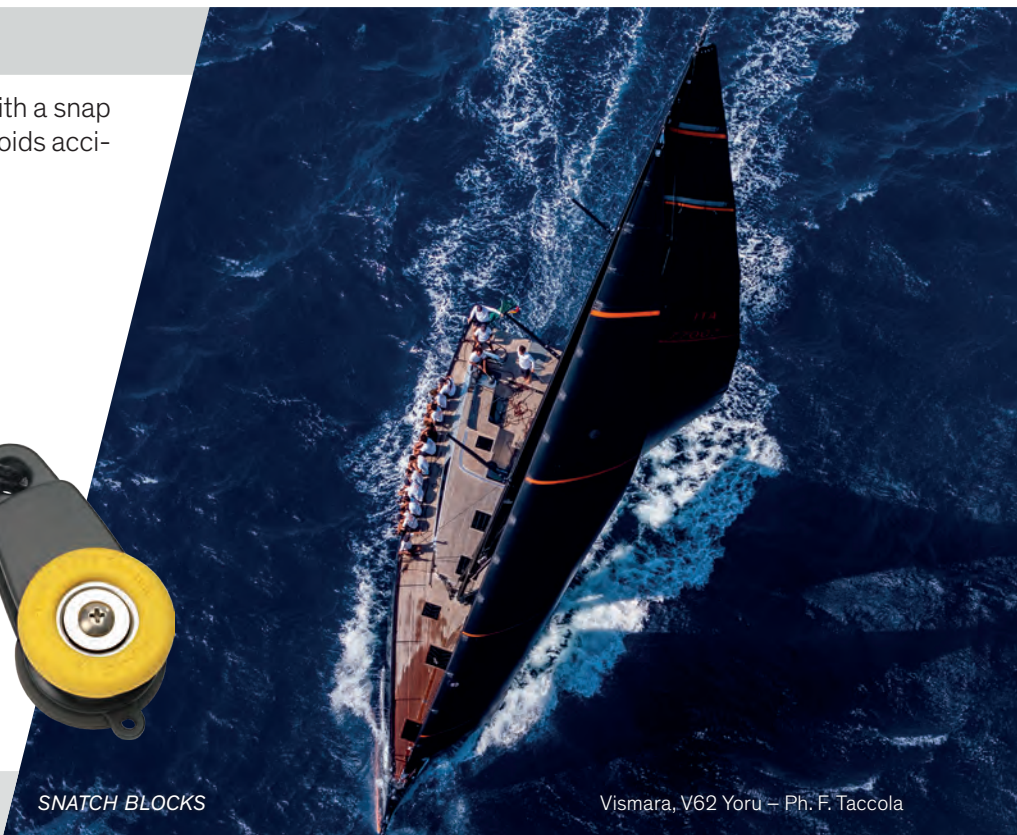

BARBER BLOCKS

BARBER BLOCKS

The new Antal Barber Block is a snatch block with a **ring head**, it provides an immediate entry of the sheet (the cheekplate revolves around the sheave axle allowing the block to open) and an easy **2:1 control** (a line through the ring allows the control of the block height). A safety ball prevents the revolving from accidental opening and an adjustable screw can set the ball in fully locked position.

MODEL	D mm	Ø LINE mm	SWL kg	WEIGHT g
BB4012	40	12	1300	160
BB6014	60	14	2000	360



A small becket to attach a line for hanging the block is present. Rubber covers to protect the deck from bumps. Aluminium sheave with Composite Fibre bushing and two side ball bearings.

MOD. TB4212

TWIN SHEAVE BLOCKS

Twin sheave at 90° to link two perpendicular lines. Aluminium sheave on "Composite Fibre" bushing and hard black anodized one piece body.

Ø SHEAVES – 42 mm
 Ø MAX LINE – 12 mm
 WEIGHT – 250 g
 SWL – 2000 kg



SNATCH LOOPER

SNATCH LOOPER

Antal Snatch block with a small sheave **suitable for high loads**, particularly designed for 2:1 main halyards.

Hard black aluminium rotating cheek plates with a Dyneema™ snap-loop protected by a polyester cover, aluminium sheave on fibre bearing.

Two sizes are available with and without a snap-loop. The Dyneema™ snap-loop, including the Dog Bone fitting, is also available separately.

MODEL	Ø SHEAVE mm	Ø LINE mm	SWL kg	WEIGHT g
↓ WITH DYNEEMA™ SNAP-LOOP				
LS046	46	14	2200	230
LS054	54	16	3500	368
↓ WITHOUT DYNEEMA™ SNAP-LOOP				
LL046	46	14	2200	170
LL054	54	16	3500	277



1



Open the block and put the line in.

2



Close the block.

3



Insert the loop.

4



Lock the loop.



MAXI SNATCH BLOCKS

SNATCH BLOCKS (D = 90 AND 120 mm)

The cheekplate revolves around the sheave axle allowing the block to open; a safety pin, which engages automatically on closing, stops the block from opening accidentally.

MATERIALS – High-strength resin sheaves, hard anodized alloy cheekplates, high-strength stainless steel (17-4-PH) structural pins.

MODEL	D mm	Ø LINE mm	SWL kg	WEIGHT kg
908.095	90	16	2500	0.41
908.125	120	20	4500	1.12

The block can be attached with webbing or better still with a fine highly resistant line made of material such as Kevlar or Spectra.

Model **SN** is supplied with a HR Wichard snap shackle.

Model **SH** is supplied with a shackle.



SNATCH BLOCK ON PAD-EYE (D = 90, 120 AND 150 mm)

Three snatch blocks 90, 120 and 150 mm diameter, on pad-eye and stand-up spring are available. The cheekplate revolves to open the block, a safety pin stops the block from opening.

Above blocks are available also on screwed pad-eye.

MODEL	Ø SHEAVE mm	SHEAVE WIDTH mm	Ø LINE mm	SWL kg	WEIGHT kg	EYEBOLT MODEL
↓ 4 SCREWS PAD-EYES						
918.095	90	26	18	2500	0.82	7210
918.125	120	36	20	4500	2.05	7214
918.155	150	46	28	6500	4.20	7220
↓ SCREWED PAD-EYES						
928.095	90	26	18	2500	1.14	7310
928.125	120	36	20	4500	2.70	7314
928.155	150	46	28	6500	5.30	7321



BLOCK ON 4 SCREWS PAD-EYE



BLOCK ON SCREWED PAD-EYE



antal 40.160

antal 40.160
made in Italy

T-TRACK SLIDERS



Genoa cars 112



Halyard sliders 121



Outhaul sliders 122



Classic S.Steel 124

26X4

GENOA CARS

MOD. 602.211 → T-TRACK 26x4

High resistance silver anodized light alloy extrusion.

MAX LENGTH – 3 m
WEIGHT – 0.5 kg/m

FASTENERS – Ø5 mm screws
HOLE SPACING – 50 mm

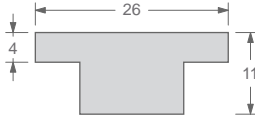

MOD. 691.141 → SIMPLE END FITTING

Plastic made, fastened with one 5 mm screw.

MOD. 690.151 → ONE SHEAVE END FITTING MOD. 690.152 → TWO SHEAVES END FITTING

Hard black anodized aluminium base and resin sheave with side ball bearings (FASTENERS – 2xØ6 mm screws).

MOD. 621.492

For boats up to **33 ft**

GENOA CAR 26x4: hard black anodized with A316 stop-pin and Nylon sliding inserts. The sheave structure, made in AISI316 S.Steel, turns left and right ($\pm 50^\circ$). Resin sheave with 2 side ball bearings, wide section for two sheets.

WEIGHT – 0.35 kg
SWL – 800 kg
STOP-PIN Ø – 8 mm

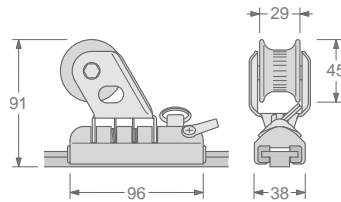

MOD. 621.452

For boats up to **30 ft**

GENOA CAR 26x4: a 50 mm block with spring is fitted on the aluminium slider. Also this model is supplied with the stop-pin.

WEIGHT – 0.25 kg
SWL – 500 kg
STOP-PIN Ø – 8 mm

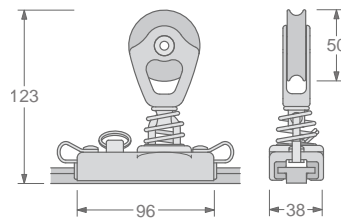

MOD. 621.462

For boats up to **33 ft**

SIMPLE SLIDER: a 6 mm shackle is fitted on the hard black anodized slider. AISI316 S.Steel stop-pin and Nylon sliding inserts.

WEIGHT – 0.21 kg
SWL – 800 kg
STOP-PIN Ø – 8 mm

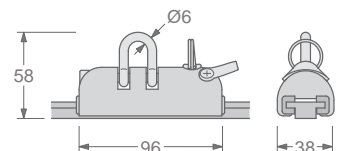

CAR CONTROL

To regulate the car position, tackles with 2:1 and 3:1 purchase can be produced. A special end fitting with 1 or 2 sheaves can be mounted on the track with one block connected to the car.

For the car control, mini blocks have been used (see page 58). Mini Blocks have a 34 mm sheave and are suitable for a 6 mm line.

CAR CONTROL 2:1

MOD. 691.141

MOD. 621.492

MOD. 00320

MOD. 690.151

CAR CONTROL 3:1

MOD. 691.141

MOD. 621.492

MOD. 00321

MOD. 690.152

MOD. 00320

34 mm block connected to the car.

MOD. 00321

34 mm block with becket connected to the car.

MOD. 690.151

Black aluminium end fitting with one 34 mm sheave.

MOD. 690.152

Black aluminium end fitting with two 34 mm sheave.



J-Boats, Mondial J80 – Ph. C. Breschi

RACE GENOA CAR

For boats up to **30 ft**

On an aluminium car a sheet block (Dynablock **MOD. DBL44**, see page 105) is tied with a Dyneema™ line. There is a 34 mm block with becket on the car that requires an end-fitting with a double block (**MOD. 690.152**) for a 3:1 car control. No stop-pin for this solution.

WEIGHT – 0.26 kg
SWL – 600 kg

MOD. 621.472

Slider without sheet block.

MOD. 621.472DBL44

Slider with sheet block.

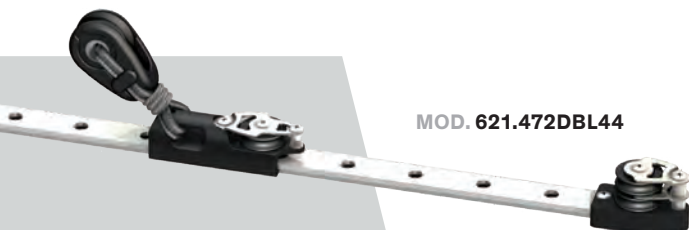

MOD. 621.472DBL44

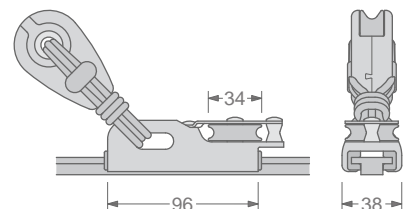

32X6

GENOA CARS

MOD. 602.112 → T-TRACK 32X6

MOD. 602.212 → T-TRACK 32X6

High resistance silver anodized light alloy extrusion. Rounded upper edges, larger base with a seat for the silicone. Hard black anodization is also available on request (add **B** to the model number).

MOD. 602.112 → 100 mm HOLE SPACING

MOD. 602.212 → 50 mm HOLE SPACING

FASTENERS – Ø6 mm screws

WEIGHT – 0.8 kg/m

MAX LENGTH – 6 m

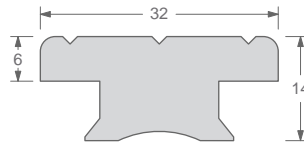

MOD. 622.492

For boats up to **44 ft**

GENOA CAR 32X6: hard black anodized aluminium slider with low-friction Nylon sliding inserts. The revolving upper structure ($\pm 50^\circ$) is made of AISI316 S.Steel. The resin sheave is fitted with 2 side ball bearing, wide section for double sheet. AISI316 S.Steel pin with a lock-up position. Becket for remote control line.

WEIGHT – 0.86 kg

SWL – 2800 kg

STOP-PIN Ø – 11 mm

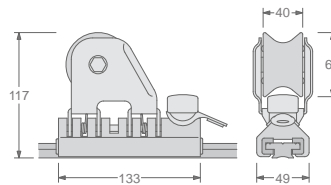

MOD. 620.492

For boats up to **38 ft**

GENOA CAR 32X6: for 32x6 T-Track, as the above model, but with smaller sizes.

WEIGHT – 0.40 kg

SWL – 800 kg

STOP-PIN Ø – 11 mm

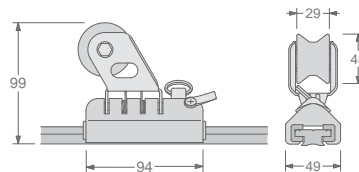

MOD. 622.462

For boats up to **38 ft**

SIMPLE SLIDER: a 10 mm shackle is fitted on the aluminium slider. Also this model is supplied with the stop-pin.

WEIGHT – 0.45 kg

SWL – 2200 kg

STOP-PIN Ø – 11 mm

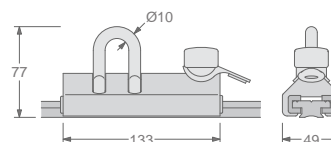

SIMPLE END FITTING

MOD. 691.241 – made in plastic
MOD. 691.241AL – silver anodized aluminium

MOD. 691.241B – black anodized aluminium
MOD. 691.241S – AISI316 S.Steel

CAR CONTROL

To regulate the car position, tackles with 2:1 and 3:1 purchase can be produced. A special end fitting with

1 or 2 sheaves can be mounted on the track and one block connected to the car.

CAR CONTROL 2:1



CAR CONTROL 3:1

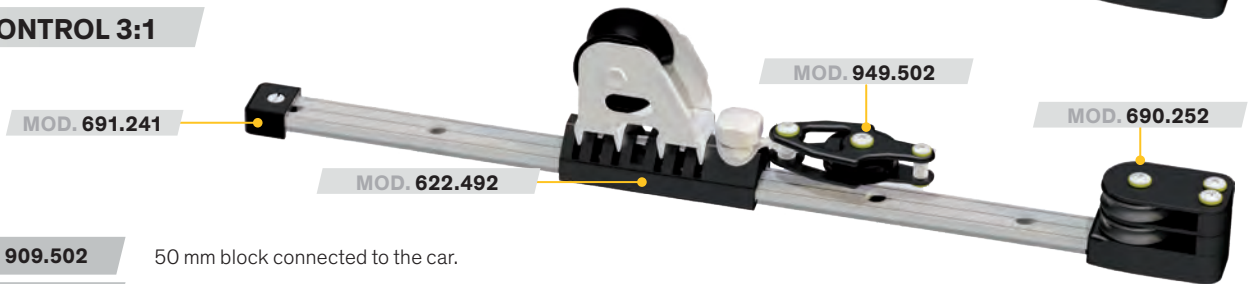

- MOD. 909.502** 50 mm block connected to the car.
- MOD. 949.502** 50 mm block with becket connected to the car.
- MOD. 690.251** Black aluminium end fitting with one 50 mm sheave.
- MOD. 690.252** Black aluminium end fitting with two 50 mm sheave.



GENOA CAR 32x6 PLUS

For boats up to **52 ft**

The "plus" genoa car runs on HS fibre sliding inserts on 32x6 T-Track. It is fitted with a stop-pin done for 11 mm holes (smaller diameter are available on request).

WEIGHT – 1.34 kg
 SWL – 3800 kg

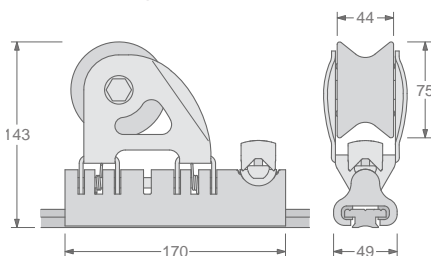

40X8

GENOA CARS

MOD. 602.113 → T-TRACK 40x8

MOD. 602.213 → T-TRACK 40x8

High resistance silver anodized light alloy extrusion. Rounded upper edges, larger base with a seat for the silicone. Hard black anodization is also available on request (add **B** to the model number).

MOD. 602.113 → 100 mm HOLE SPACING

MOD. 602.213 → 50 mm HOLE SPACING

FASTENERS – 8 mm screws

WEIGHT – 1.3 kg/m

MAX LENGTH – 6 m

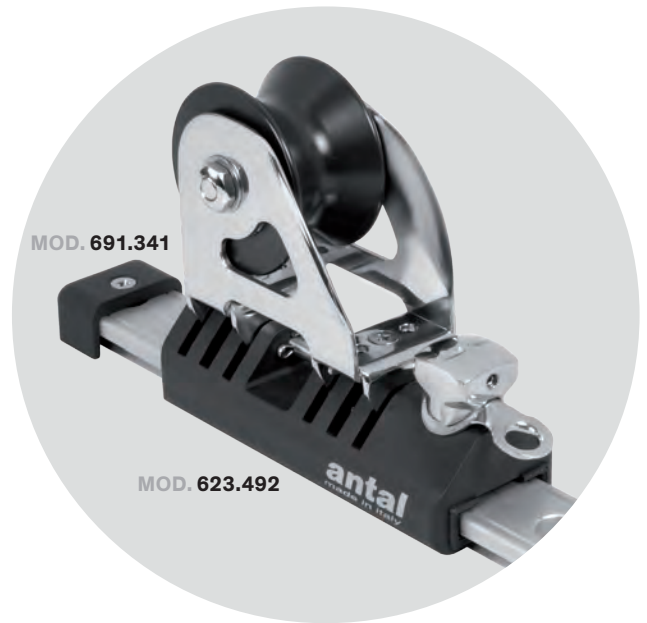
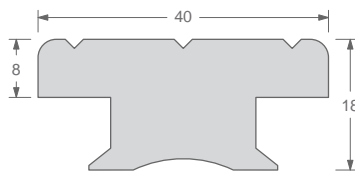

MOD. 623.492

For boats up to **52 ft**

GENOA CAR 40x8: hard black anodized aluminium slider with low-friction Nylon sliding inserts. The revolving upper structure ($\pm 50^\circ$) is made of AISI316 S.Steel. The aluminium sheave is fitted with one main Composite Fibre bearing and 2 side ball bearing, wide section for double sheet. AISI316 S.Steel pin with a lock-up position. Becket for remote control line.

WEIGHT – 1.50 kg

SWL – 3800 kg

STOP-PIN \varnothing – 14 mm

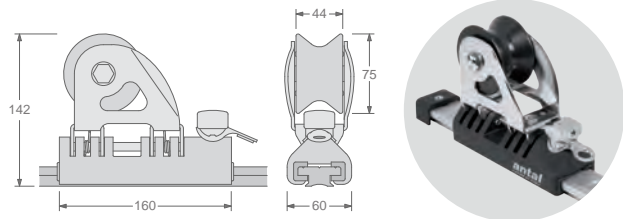

MOD. 623.462

For boats up to **52 ft**

SIMPLE SLIDER: a 12 mm shackle is fitted on the aluminium slider. Also this model is supplied with the stop-pin.

WEIGHT – 0.79 kg

SWL – 3300 kg

STOP-PIN \varnothing – 14 mm

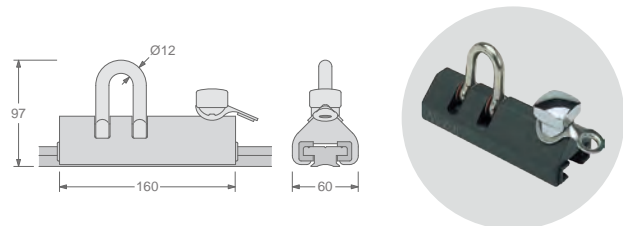

SIMPLE END FITTING

MOD. 691.341 – made in plastic

MOD. 691.341AL – silver anodized aluminium

MOD. 691.341B – black anodized aluminium

MOD. 691.341S – AISI316 S.Steel

CAR CONTROL

To regulate the car position, tackles with 2:1 and 3:1 purchase can be produced. A special end fitting with

1 or 2 sheaves can be mounted on the track and one block connected to the car.

CAR CONTROL 2:1



CAR CONTROL 3:1



- MOD. 909.502** 50 mm block connected to the car.
- MOD. 949.502** 50 mm block with becket connected to the car.
- MOD. 690.351** Black aluminium end fitting with one 50 mm sheave.
- MOD. 690.352** Black aluminium end fitting with two 50 mm sheave.

MOD. 626.492 → MAXI GENOA SLIDER

For boats up to **60 ft**

The new genoa slider **MOD. 626.492** has a stronger and more rigid steel structure, suitable for boats up to 60ft, fitted with a wide sheave 100 mm diameter. It is done for the 40x8 T-Track **MOD. 602.213** and we recommend the use of the double pin stop **MOD. 691.722B**.

WEIGHT – 2.12 kg
SWL – 4800 kg

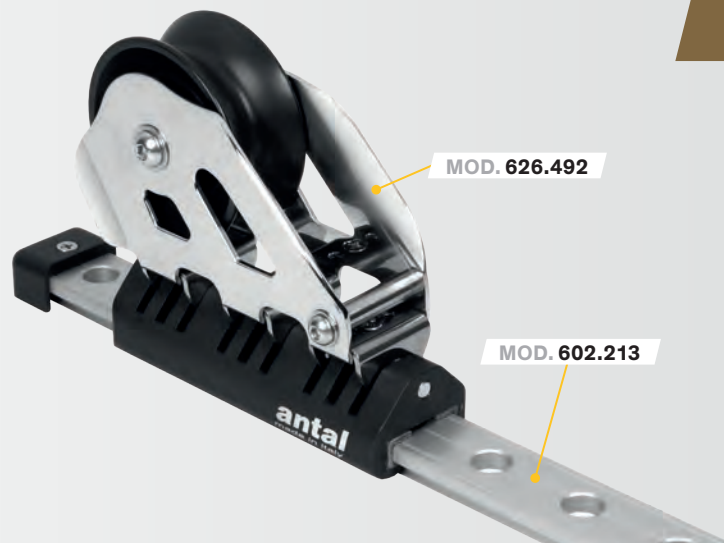
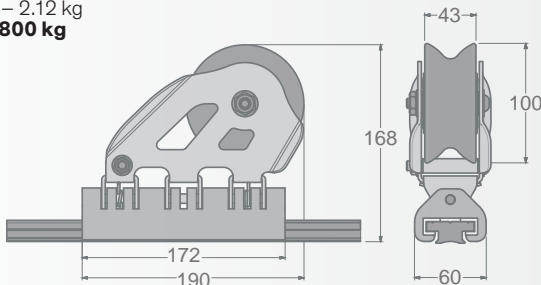

MOD. 691.722B

DOUBLE STOP-PIN: for the double stop-pin with alu slider the 50 mm hole spacing track (**MOD. 602.213**) is necessary.

STOP-PIN Ø – 14 mm



DOUBLE 40X8

GENOA CARS

DOUBLE 40X8 GENOA CARS SHEAVES 120, 150, 180 mm

The double 40X8 genoa cars are made for maxi yachts (larger than 60 ft), they run on 40X8 T-Track (see page 116).

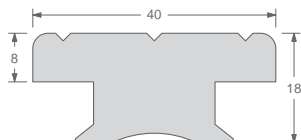

Two hard black anodized aluminium sliders (add **B** after the model number) or two polished S.Steel sliders (add **S** after the model number) running on Nylon guides are connected with a revolving ($\pm 50^\circ$) link structure. The sheave, with a wide sections for a double sheet, is fitted with a main Composite Fibre bearing and two side self-captive ball bearings.



Hylas Yachts, H60



MODEL	D mm	L mm	SWL kg	WEIGHT kg
623.120B	120	330	5000	3.10
623.150B	150	330	6500	4.25
623.180B	180	375	9000	6.20

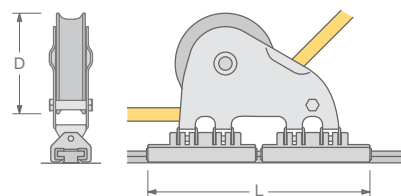

All the above double cars are available with S.Steel sliders. The double stop-pin and the T-Track are also available in S.Steel. Substitute **S** for **B** in the model number.

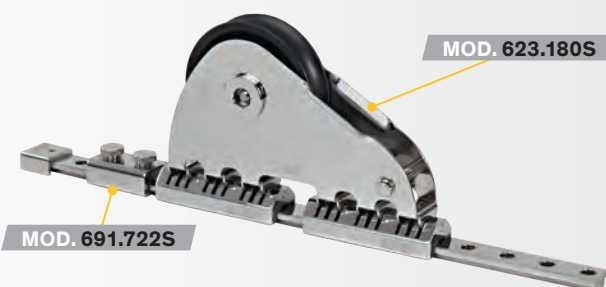

STOP-PIN

A special double stop-pin ($\varnothing 14$ mm) is available to lock the car in position on the track:

MOD. 691.722B – Hard black anodized aluminium
MOD. 691.722S – Polished S.Steel

With the double stop-pin the 50 mm hole spacing track (**MOD. 602.213**) is necessary.



MOD. 691.722B



T-TRACKS

T-TRACKS

Antal produces three sizes of T-Tracks: 26×4, 32×6 and 40×8. T-Tracks are available in the three versions silver aluminium, hard black anodized aluminium and S.Steel, all with 50 and 100 mm hole spacing.

On request, track will be machined with rounded ends and then anodized. Moreover, 32×6 and 40×8 sizes are also made with holes for automatic locking of the slider, in hard black anodized version.

1

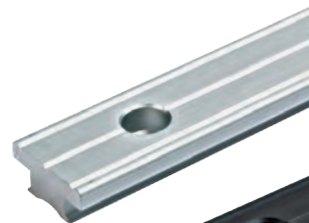

2

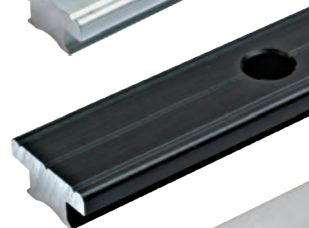



3



1 Silver anodizing

2 Hard black anodizing

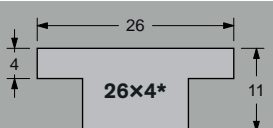
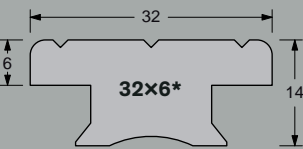
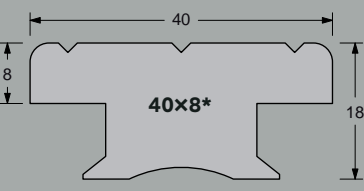
3 S.Steel with rounded head

SIZE	HOLE SPACING mm	SILVER	BLACK	S.STEEL	
↓ STANDARD TRACK					
	50	602.211	602.211B	-	
	50	602.212	602.212B	602.212S	
	100	602.112	602.112B	602.112S	
	50	602.213	602.213B	602.213S	
	100	602.113	602.113B	602.113S	
↓ AUTOMATIC TRACK					
	32×6	50	-	602.312	-
	40×8	50	-	602.313	-

* Tracks real sizes.

Amel 50 – Ph. R. Christol



HALYARD SYSTEM

HALYARD SLIDER

The "halyard slider" has been specifically planned for wire halyards and for those halyards which are subject to such high strain as to preclude use of a stopper. This solution permits easy adjustment and secure locking of halyards.



Numbered slider positions

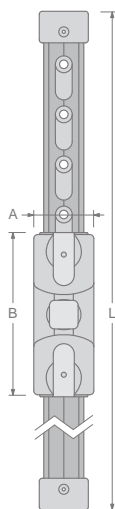
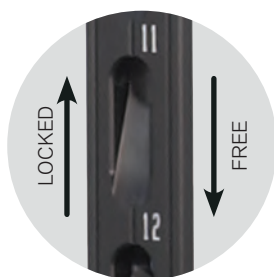

AUTOMATIC TRACK

The special shape of the holes allows the car moving with the stop-pin on and the automatic car lock in the new position.

THE COMPLETE SYSTEM INCLUDES

- Hard black aluminium T-Track automatic version, with fixed length and with numbered positions of the slider, positioning holes spacing = 50 mm, fixing screws spacing = 100 mm.
- The halyard slider with the 2-positions stop-pin: locked and automatic insertion.
- 2 simple aluminium end fittings for T-Track.

Also automatic tracks of any length, up to 6 m, are available. In this case, the positioning holes are not numbered (32×6, **MOD. 602.312** – 40×8, **MOD. 602.313**).

ADJUSTING AND BLOCKING THE HALYARD

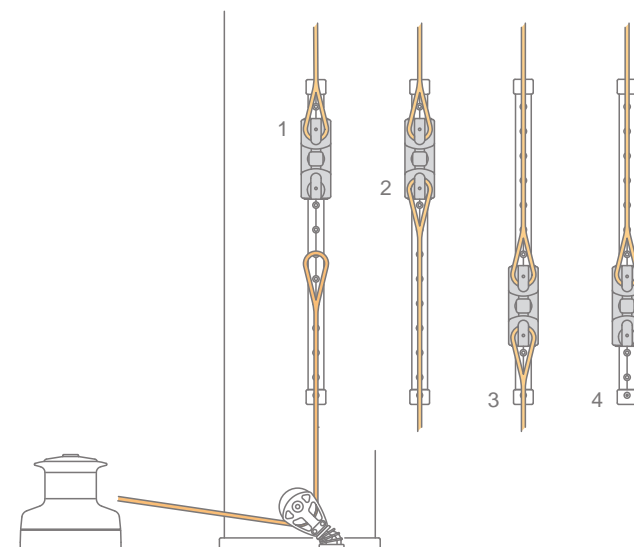

- 1 – Hook the halyard to the slider.
- 2 – Connect the winch.
- 3 – Put the halyard under tension and lock it in place.
- 4 – Free the slider from the winch.

COMPLETE SYSTEM		TRACK			SLIDER			END FITTING
MODEL	SWL kg	MODEL	SIZE mm	L mm	MODEL	A mm	B mm	MODEL
622.422	2000	602.412	32×6	990	622.402	50	135	691.241B
623.422	3000	602.413	40×8	1130	623.402	60	160	691.341B
624.422	5000	602.413	40×8	1130	624.402*	60	210	691.341B

* Car with double stop-pin.

OUTHAUL CARS

MAXI

OUTHAUL SLIDERS

This slider runs on self-lubricating HS fibre enabling it to deal with heavy work loads while remaining compact; it also provides low friction running and easy manoeuvring. The sail connection, which is made of S.Steel and revolves, reduces the height of the sail

FOR BOATS UP TO 48 ft

→ 32×6 T-Track

FOR BOATS UP TO 70 ft

→ 40×8 T-Track

above the boom to a minimum. Standard T-Tracks, sizes 32×6 and 40×8, are used, with black anodized finish and 50 mm hole spacing. The car runs on self-lubricating HS fibre and with hard black anodized track.

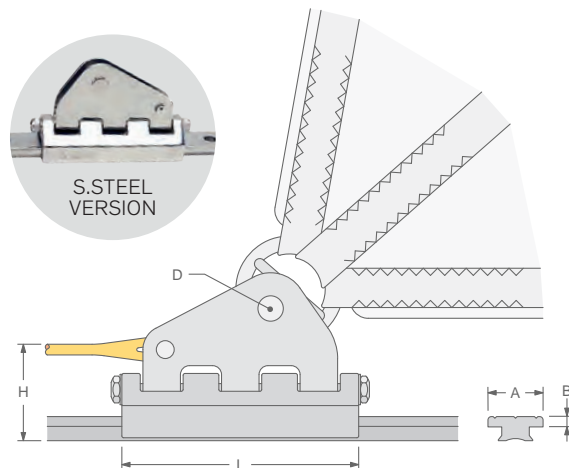

↓ CAR					
MODEL	L mm	H mm	D mm	WEIGHT kg	SWL kg
672.002	130	60	12	0.50	3000
672.003	160	80	16	1.23	6000
672.004	200	80	16	1.68	8000
672.005	280	90	20	3.55	10000

↓ TRACK				
MODEL	A × B mm	SCREWS Ø mm	SPACING mm	WEIGHT kg/m
602.212B	32×6	6	50	0.80
602.213B	40×8	8	50	1.30



OUTHAUL CARS



FURLING MAIN

OUTHAUL CAR WITH SHEAVE

A ball bearing car is necessary for the outhaul of a furling main sail.

Two sizes: 190 mm car with a 60 mm sheave and 260 mm car with a 90 mm sheave, both on **Antal 4Race** 31x21 tracks.

A special clew-block completes the system.

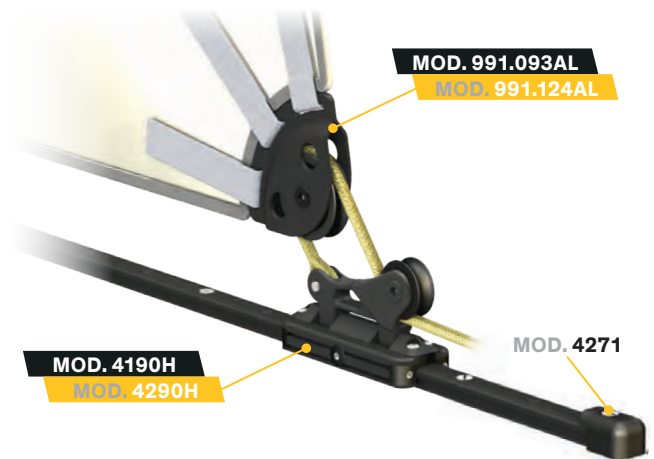

	↓ CAR					↓ CLEW BLOCK	
	MODEL	LENGTH mm	SHEAVE Ø mm	SWL kg	WEIGHT kg	MODEL	SHEAVE Ø mm
For boats up to 48 ft	4190H	190	60	1900	0.85	991.093AL	90
For boats up to 56 ft	4260H	260	90	2800	1.36	991.124AL	120

OUTHAUL CAR – DIRECT CONNECTION

This simple solution reduces the load on the car but increases the tension of the line.

Three sizes with cars 110, 150 and 190 mm long, on **Antal 4Race** 31x21 tracks.

In this case too a special clew block completes the system.

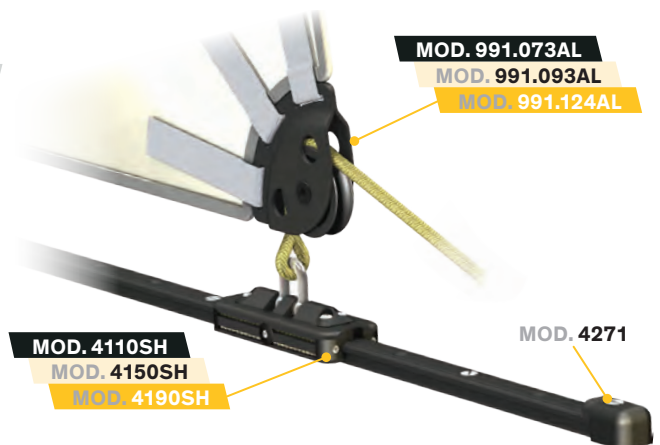

	↓ CAR				↓ CLEW BLOCK	
	MODEL	LENGTH mm	SWL kg	WEIGHT kg	MODEL	SHEAVE Ø mm
For boats up to 40 ft	4110SH	110	1000	0.37	991.073AL	75
For boats up to 48 ft	4150SH	150	1400	0.48	991.093AL	90
For boats up to 56 ft	4190SH	190	1900	0.70	991.124AL	120

TRACK

Two track models are available for the cars described on this page.

For both **MOD. 4510** and **4560**:

FIXING SCREWS – Ø8 mm
HOLE SPACING – 100 mm
WEIGHT – 0.77 kg/m
END-FITTING – **MOD. 4271**

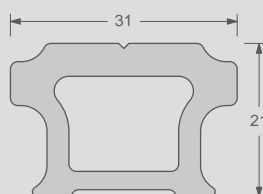

MOD. 4510 → DIRECT MOUNTING

The track is directly screwed to threaded holes on the boom.

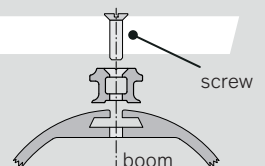

MOD. 4560 → SLUG MOUNTING

The track is screwed to the slugs. Slugs are custom made to fit the groove of the boom.

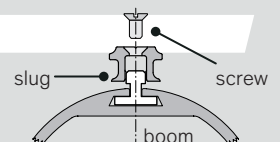

CLASSIC S.STEEL

FOR GENOA

32x6 GENOA CAR

L = 132 mm ALUMINUM SHEAVE = 60 mm SWL = 2800 kg

40x8 GENOA CAR

L = 160 mm ALUMINUM SHEAVE = 75 mm SWL = 3800 kg

Antal offers a complete series of cars for genoa and mainsail with tracks and accessories completely made in 316 polished S.Steel.

Particularly designed for classic boats.

Two sizes: with 32x6 and 40x8 S.Steel T-tracks. 50 mm sheaves for all cars control.

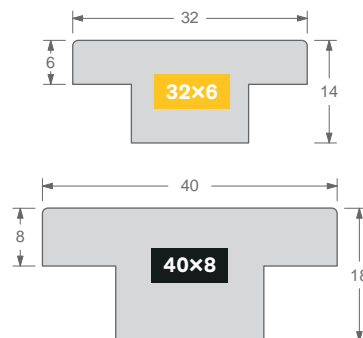

→ MODELS FOR T-TRACK SIZE 32x6

→ MODELS FOR T-TRACK SIZE 40x8



CLASSICS.STEEL

FOR MAIN SAIL

32x6 MAIN CAR

with one block size **75 mm**
with two blocks size **75 mm**

L = **132 mm**
L = **180 mm**

SWL = **1500 kg**
SWL = **2000 kg**

40x8 MAIN CAR

with one block size **90 mm**
with two blocks size **90 mm**

L = **160 mm**
L = **200 mm**

SWL = **2500 kg**
SWL = **3500 kg**

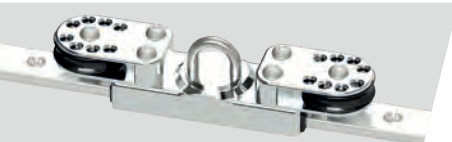

All the cars on this page are also available without the sheet block and with a simple eyebolt. To order this version, just end the model code after **S**.

E.g. **MOD. 622.512S**



CAR CONTROL 1:1

75 mm block included

90 mm block included



CAR CONTROL 2:1

75 mm block included

90 mm block included

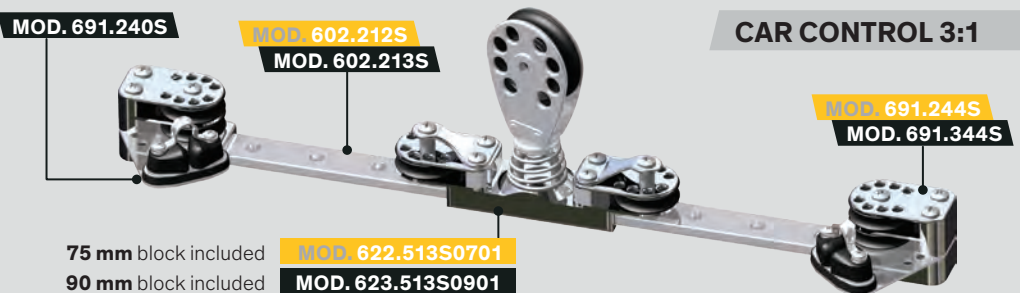

CAR CONTROL 3:1

75 mm block included

90 mm block included



CAR CONTROL 3:1

Double block version

50 mm sheaves for all cars control. For Classic Blocks, see page 84.



antal
made in italy

BALL BEARING CARS



Size 100 129



Sizes 110-150-190-230-260 132



Dyneema™ links 140

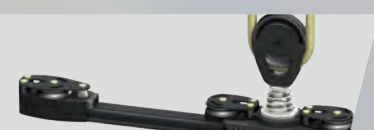

Maxi 47 Sizes 230-330-430 146



Maxi 67 Sizes 330-430-530 150



Life Rail System 153

BALL BEARING

CARS

CHARACTERISTICS

- Higher efficiency and smoother running.
- Better load resistance to vertical (**V**), horizontal (**H**) and torsional (**M**) loads.
- Higher safety margin as the car will remain on the track even after ball bearing failure (overload).
- Travellers are fitted with 2 Torlon ball circuits (lower) and 2 Delrin ball circuits (upper).
- Single double and triple control sheaves, with or without becket, can be fitted on the car.
- One-piece extruded body.
- The traveller, the track and all components are extruded in high strength alloy and hard black anodized (Steel parts: AISI316).
- Side windows for easy maintenance and ball bearing cleaning and/or replacement.
- Standard shackle or special "stand-up" joint.

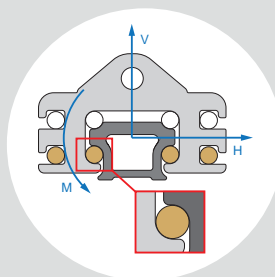
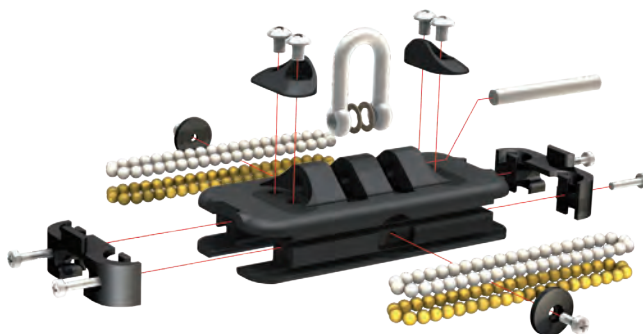

V – VERTICAL LOAD
H – HORIZONTAL LOAD
M – TORSIONAL LOAD

TRACK	CAR SIZE mm	FOR BOATS UP TO ft	PAGE
	100	33	129
	110	36	132
	150	42	
	190	48	
	260	52	
	230	60	146
	330	70	
	430	80	
	330	70	150
	430	80	
	530	100	



SIZE 100



MOD. 4102SH → CAR SIZE 100

This car is fitted with 54 Delrin + 54 Torlon balls.
WEIGHT – 0.23 kg
SWL – 820 kg

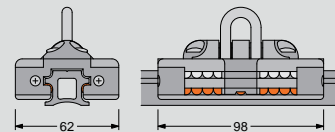

MOD. 601.121 → STANDARD TRACK

Tubular hard black anodized aluminium extrusion.
FASTENERS – 6 mm screws / 100 mm hole spacing
WEIGHT – 0.69 kg/m
MAX LENGTH – 6 m

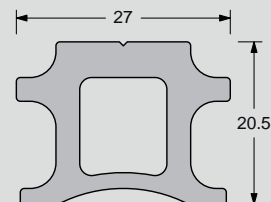

MOD. 601.221 → STOP-PIN TRACK

As the above model but with holes (50 mm spacing) for the stop-pin.



MOD. 691.421 → STOP-PIN

Aluminium slider on Nylon inserts and AISI316 S.Steel pin.
The stop-pin needs to be fitted on the **MOD. 601.221** track.

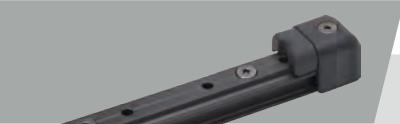
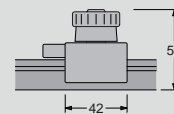

MOD. 4261 → SIMPLE END FITTING

Plastic made, mounted with a 6 mm screw.

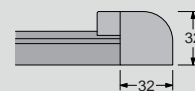

MOD. 4262 → END FITTING WITH ONE SHEAVE

High strength resin made with one Ø35 mm sheave.
Completed with a shock proof rubber.
WEIGHT – 0.08 kg
SCREWS – 3×Ø5 mm

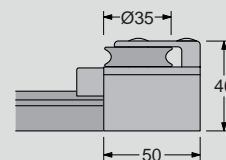

MOD. 4263 → END FITTING WITH ONE SHEAVE AND BECKET

High strength resin made with one Ø35 mm sheave.
Completed with a shock proof rubber.
WEIGHT – 0.10 kg
SCREWS – 3×Ø5 mm

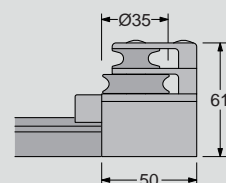

MOD. 4264 → END FITTING WITH TWO SHEAVES

High strength resin made with two Ø35 mm sheaves.
Completed with a shock proof rubber.
WEIGHT – 0.10 kg
SCREWS – 3×Ø5 mm

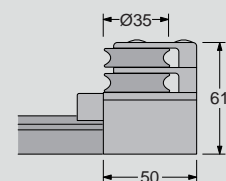

MOD. 4266 → END FITTING CAM-CLEAT

This cam-cleat revolving in 3 different positions can be fitted on the end fitting with one or two sheaves.



MAIN CARS

SIZE 100



MAIN BALL BEARING TRAVELLER SIZE 100

For boats up to 33 ft

This traveller is 98 mm long and 62 mm wide. The weight is 0.23 kg and the **working load = 820 kg**. The sheaves for the car control are $D = 35$ mm. The complete systems includes 1.5 m long track. The sheet block (OPF 60, page 66) is **not included**.

The blocks in the OPF series to be mounted on the 4Race cars must have a special long swivel head as described on page 63; add **J** to the block model code.

The traveller is fitted with a special "stand-up" connection for Antal block size 60 mm and includes the "stand-up" rubber.



MOD. 4100

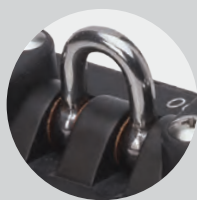

MOD. 4100SH

The same traveller is also available with a 6 mm shackle (for this case add **SH** to the model number).

STOP-PIN CAR CONTROL

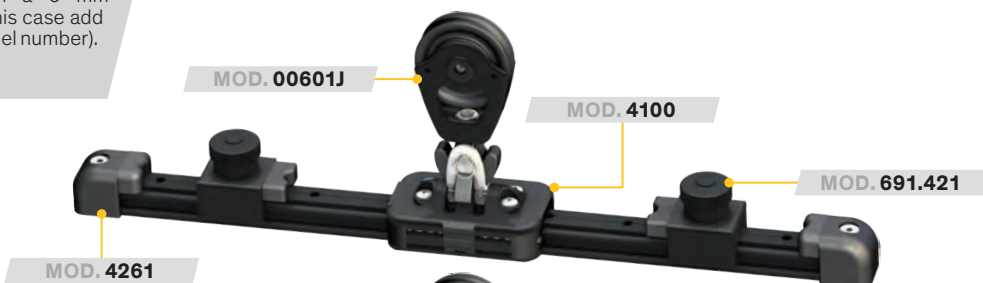

CAR CONTROL 1:1



CAR CONTROL 2:1



CAR CONTROL 3:1



GENOA CARS

SIZE 100

 4RACE



TRACK 27x20
Page 129

BALL BEARING GENOA TRAVELLER SIZE 100

For boats up to 33 ft

This traveller is 98 mm long and 62 mm wide. The weight is 0.40 kg and the Working Load = 820 kg. Can be fitted with a front sheave with becket for a **3:1 control**.

Main sheave (diameter 45 mm) with 2 side ball bearings and a wide section suitable for 2 sheet. The sheaves for the car control are $D = 35$ mm.

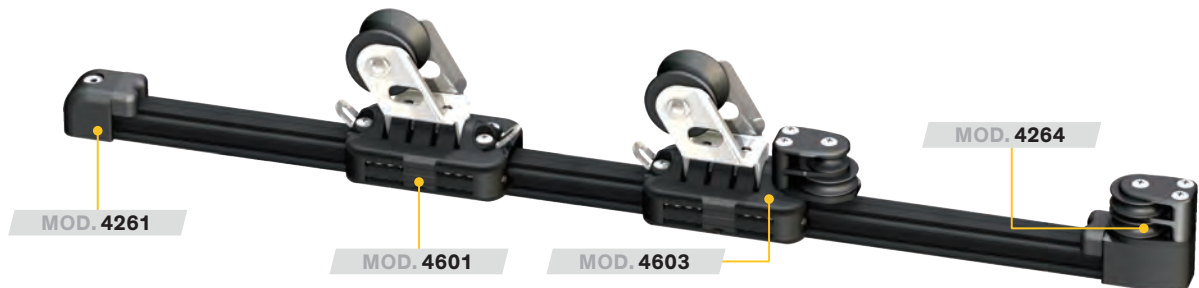

SIZES

110-150-190-230-260



TRACK 31x21

MOD. 4510

STANDARD TRACK 31x21

Fastening screws from the top.

SCREWS – 8 mm
HOLE SPACING – 100 mm
WEIGHT – 0.77 kg/m

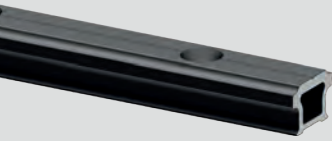

MOD. 4520

STANDARD TRACK WITH STOP-PIN HOLES

Fastening from the top.

SCREWS – 8 mm
HOLE SPACING – 100 mm
STOP-PIN HOLE SPACING – 50 mm
WEIGHT – 0.75 kg/m

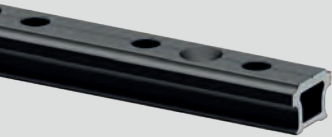

MOD. 4530

RACE TRACK 31x21 WITH LIGHTENING HOLES

Fastening from the bottom.

SCREWS – 8 mm
HOLE SPACING – 100 mm
WEIGHT – 0.64 kg/m

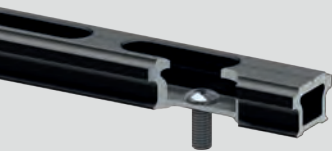

MOD. 4540

ADJUSTABLE FASTENER TRACK 31x21

Bolts can be fixed in any position, for pre-existing holes.

SCREWS – 8 mm (on sliding slugs)
WEIGHT – 0.72 kg/m

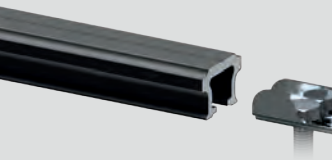

MOD. 4541

MOD. 4550N

HIGH PROFILE TRACK 48x60

Bolts can be fixed in any position.

Sliding slugs with 2xØ8 mm screws (MOD. 4543) are available (the slug is divisible in half).

TRACK WEIGHT – 3.2 kg/m
UNSUPPORTED SPAN MAX – 1.5 m

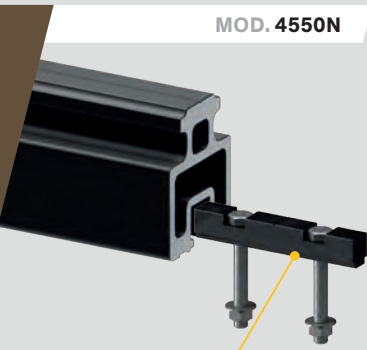

MOD. 4551N
Special end fitting for 48x60 track.

MOD. 4543



TRAVELLER SIZE AND LOAD TABLE

Three models: **110**, **150** and **190** mm long, for boats up to 48 ft. These cars are fitted with standard shackle (**SH**), but also special "stand-up" joint for 70, 80 and 100 mm blocks is available.

Longer cars are available: L = 230 mm (**SWL – 2400 kg**) and L = 260 mm (**SWL – 2800 kg**) described in the following page 137.

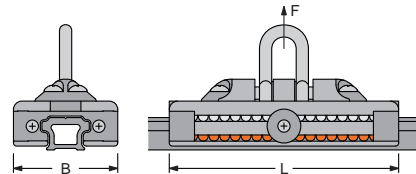

TRAVELLER SIZE AND LOAD TABLE

MODEL	L mm	B mm	SWL kg	WEIGHT kg	N° BALLS
4110SH	110	70	1000	0.50	62 Delrin + 62 Torlon
4150SH	150		1400	0.70	86 Delrin + 86 Torlon
4190SH	190		1900	0.90	112 Delrin + 112 Torlon

TRAVELLER LENGTH ft	LOA ft												TRAVELLER SWL kg		
	28	30	32	34	36	38	40	42	44	46	48	50		52	
100	█	█	█	█											820
110		█	█	█	█										1000
150			█	█	█	█									1400
190				█	█	█	█								1900
230					█	█	█	█							2400
260						█	█	█	█						2800

TRAVELLER SELECTION GUIDE FOR: MAINSHEET (END BOOM) AND GENOA SHEET



MOD. 4291 → STOP-PIN

Aluminium slider on Nylon inserts and AISI316 S.Steel pin. The stop-pin needs to be fitted on the **MOD. 4520** track. Knob with 2 positions: free and lock.

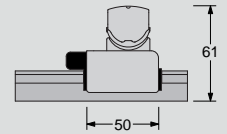

MOD. 4271 → SIMPLE END FITTING

Plastic made, mounted with a 8 mm screw.

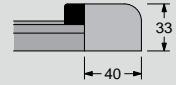

MOD. 4272 → END FITTING WITH ONE SHEAVE

Aluminium made with one $\varnothing = 45$ mm sheave fitted with double side ball bearings. Completed with a shock proof rubber.

WEIGHT – 0.21 kg
SCREWS – 3× $\varnothing 6$ mm

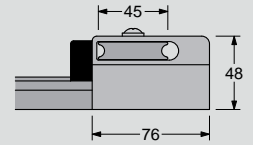

MOD. 4273 → END FITTING WITH ONE SHEAVE AND BECKET

Aluminium made with one $\varnothing = 45$ mm sheave fitted with double side ball bearings. Completed with a shock proof rubber.

WEIGHT – 0.26 kg
SCREWS – 3× $\varnothing 6$ mm

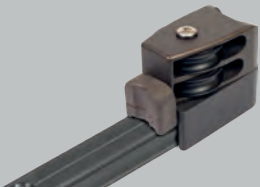
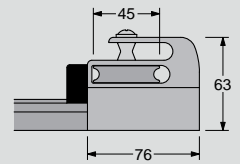

MOD. 4274 → END FITTING WITH TWO SHEAVES

Aluminium made with two $\varnothing = 45$ mm sheaves fitted with double side ball bearings. Completed with a shock proof rubber.

WEIGHT – 0.28 kg
SCREWS – 3× $\varnothing 6$ mm

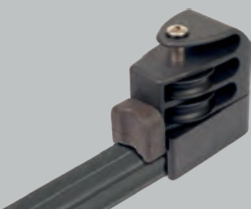
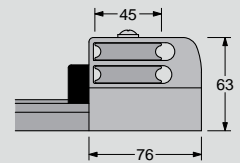

MOD. 4275 → END FITTING WITH TWO SHEAVES AND BECKET

Aluminium made with two $\varnothing = 45$ mm sheaves fitted with double side ball bearings. Completed with a shock proof rubber.

WEIGHT – 0.32 kg
SCREWS – 3× $\varnothing 6$ mm

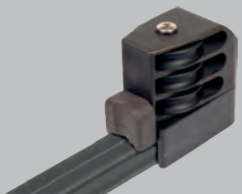
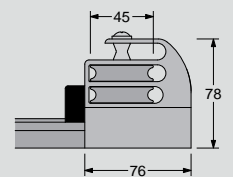

MOD. 4276 → END FITTING WITH THREE SHEAVES

Aluminium made with three $\varnothing = 45$ mm sheaves fitted with double side ball bearings. Completed with a shock proof rubber.

WEIGHT – 0.35 kg
SCREWS – 3× $\varnothing 6$ mm

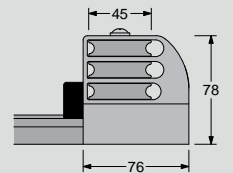

MOD. 4410 → END FITTING CAM-CLEAT

MOD. 4420 → 110 mm TRAVELLER CAM-CLEAT

MOD. 4430 → 150-190 mm TRAVELLER CAM-CLEAT



The revolving cam-cleat (3 different positions) can be fitted on the end fitting with one, two or three sheaves. The traveller cam-cleat is not revolving.

MAIN CARS

SIZE 110



SIZE 110

For boats up to **36 ft**



This traveller, 110 mm long (**SWL – 1000 kg**), is fitted with a special "stand-up" connection for Antal block size 70 mm and includes the "stand-up" rubber. The same traveller is also available with an 8 mm shackle (for this case add **SH** to the model number).

The complete system includes 1.5 m long track. The sheet block (OPF 70, page 68) is **not included**.

STOP-PIN CAR CONTROL



CAR CONTROL 2:1



CAR CONTROL 3:1



CAR CONTROL 3:1*

* Cam-cleat on the car



CAR CONTROL 4:1*

* Cam-cleat on the car



MAIN CARS

SIZE 150



SIZE 150

For boats up to **42 ft**



This traveller, 150 mm long (**SWL – 1400 kg**), is fitted with a special "stand-up" connection for Antal block size 80 mm and includes the "stand-up" rubber. The same traveller is also available with an 8 mm shackle (for this case add **SH** to the model number). The complete system includes 1.5 m long track. The sheet block (OPF 80, page 70) is **not included**.

The blocks in the OPF series to be mounted on the 4Race cars must have a special long swivel head as described on page 63; add **J1** to the block model code.

CAR CONTROL 3:1



CAR CONTROL 4:1



CAR CONTROL 5:1



CAR CONTROL 4:1*

* Cam-cleat on the car



CAR CONTROL 5:1*

* Cam-cleat on the car



MAIN CARS

SIZE 190



TRACK 31x21
Page 132

SIZE 190

For boats up to **48 ft**



This traveller, 190 mm long (**SWL – 1900 kg**), is fitted with a special "stand-up" connection for one or two Antal sheet blocks (size 80 mm) and includes the "stand-up" rubber. The same traveller is also available with a 10 mm shackle (for this case add **SH** to the model number). The complete system includes 2 m long track. The sheet blocks (OPF 80, page 70) are **not included**.

The blocks in the OPF series to be mounted on the 4Race cars must have a special long swivel head as described on page 63; add **J2** to the block model code.

CAR CONTROL 4:1



CAR CONTROL 5:1



CAR CONTROL 5:1*

* Cam-cleat on the car



CAR CONTROL 6:1*

* Cam-cleat on the car



CAR CONTROL 4:1*

* Cam-cleat on the car

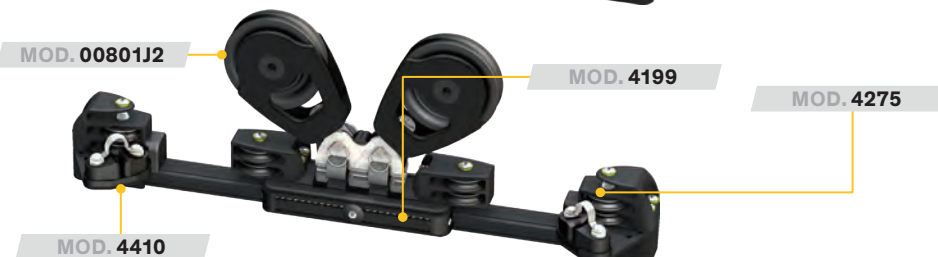

MAIN CARS

SIZE 260



TRACK 31x21
Page 132

SIZE 260

For boats up to **52 ft**

This traveller, 260 mm long (**SWL – 2800 kg**), is fitted with a special connection for one (size 100 mm) or two (size 80 mm) Antal sheet blocks and with 55 mm control sheaves. The complete system includes 2.5 m long track.

The sheet blocks (OPF 80 and 100, page 70-71) are **not included**. The blocks in the OPF series to be mounted on the 4Race cars must have a special long swivel head as described on page 63; add **J2** to the block model code.

CAR CONTROL 3:1



MAINSHEET SYSTEM 2:1

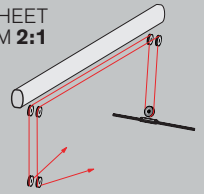

CAR CONTROL 4:1

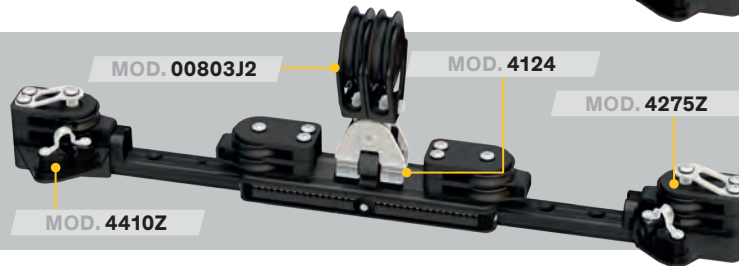

MAINSHEET SYSTEM 4:1

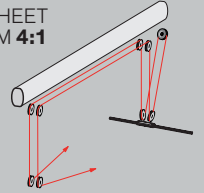

CAR CONTROL 3:1

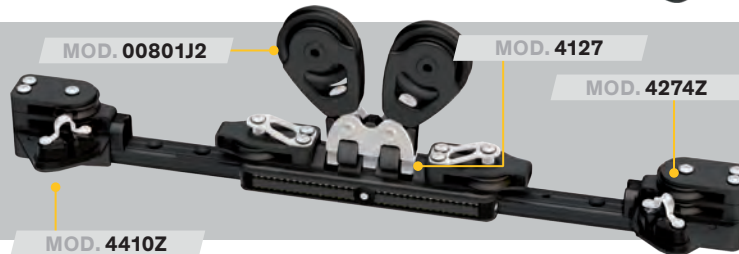

MAINSHEET SYSTEM 2:1

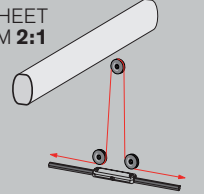

MAIN CARS

DOUBLE & TRIPLE



TRACK 31x21
Page 132

MAINSHEET
SYSTEM 2:1

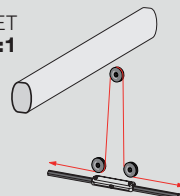

CAR CONTROL 2:1

MOD. 00801J2

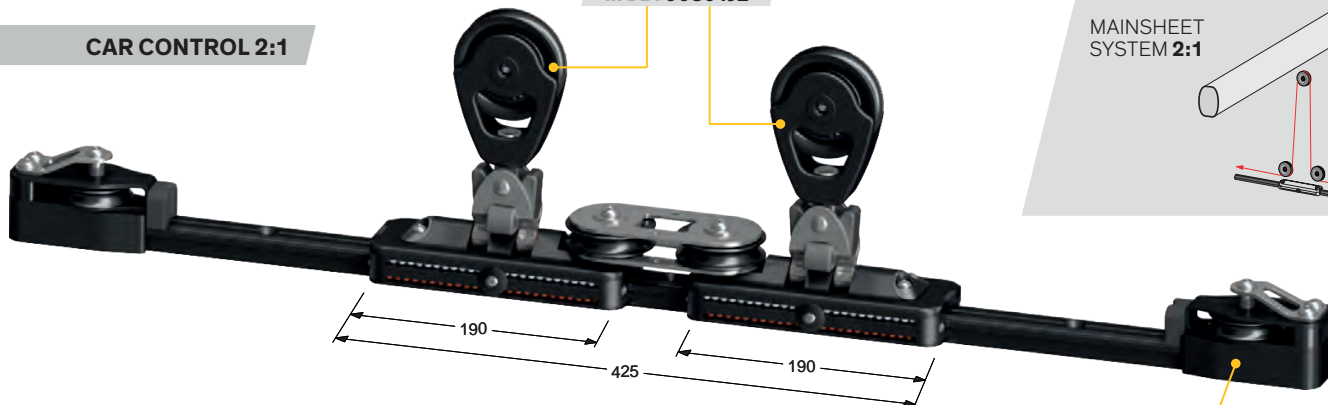

MOD. 5194 SWL – 3800 kg

The double car is obtained with 2x190 mm long cars with two D = 65 mm sheaves for a 2:1 control. For catamarans up to **50 ft LOA**. The mainsheet blocks (OPF 80, page 70) are **not included**.

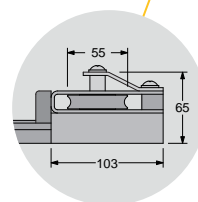

MOD. 4273Z
End fitting, 1 sheave
(D = 55 mm) and becket

The blocks in the OPF series to be mounted on the 4Race cars must have a special long swivel head as described on page 63; add **J** to the block model code.

Privilège



CAR CONTROL 2:1

MOD. 00801J2

MOD. 00801J1

MOD. 00801J1

MAINSHEET
SYSTEM 4:1

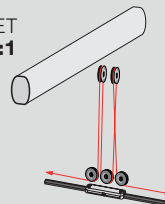

MOD. 5197 SWL – 4400 kg

MOD. 4273Z

The triple car is obtained with 2x150 and 1x190 mm long cars with two D = 70 mm blocks (OPF 70, page 68) for a 2:1 control.

For catamarans up to **60 ft LOA**. The mainsheet blocks (OPF 80, page 70) are **not included**.

FLAT SERIES



4RACE BB CARS FLAT SERIES

All the 4Race ball-bearing cars are also available in flat versions with 2 threaded holes for an easy connection with other systems, for example, in steering systems or for driving large sliding hatches, etc.

These cars are fitted with 4 circuits of Torlon balls providing compression loads as high as the pulling loads and greater torsional resistance.

More information about the 27×20 track on page 129 and about the 31×21 track on page 132.

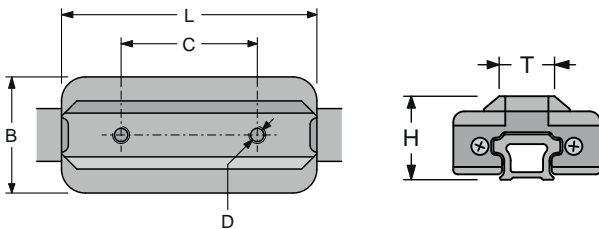

TRAVELLER SIZE AND LOAD TABLE

MODEL	TRACK SIZE mm	L mm	B mm	C mm	D mm	H mm	T mm	SWL kg	WEIGHT kg	N° BALLS
4100F	27 × 20.5	98	62	43	6	31.5	24	820	0.20	108
4110F	31 × 21	110	70	65	8	39	26	1000	0.44	124
4150F		150		80	10			1400	0.64	172
4190F		190		103	10			1900	0.79	224



BALL BEARING CARS



FOR DYNEEMA™ LINKS

CARS FOR DYNEEMA™ LINKS

Four ball bearing models, 110, 150, 190 and 230 mm long, for the same track 31×21 (see page 132) fitted with a special aluminium pivoting bracket suitable for Dyneema™ links, for both: 2 side control lines and one central connection for a sheet block or a sheet Ring.

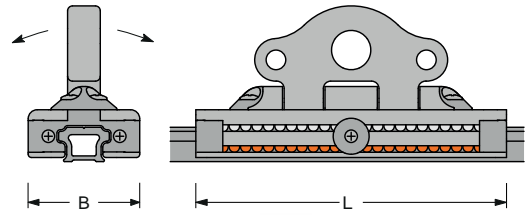

MODEL	L mm	B mm	SWL kg	WEIGHT kg
4110D	110	70	1000	0.45
4150D	150		1400	0.65
4190D	190		1900	0.85
4230D	230		2400	1.05



Wraceboats, GP26

TRANSVERSAL CARS FOR GENOA SHEET

The transversal car is fitted with a direct control for car moving outwards and inwards. A ring, through which the sheet runs, allows the height control of the genoa sheet.

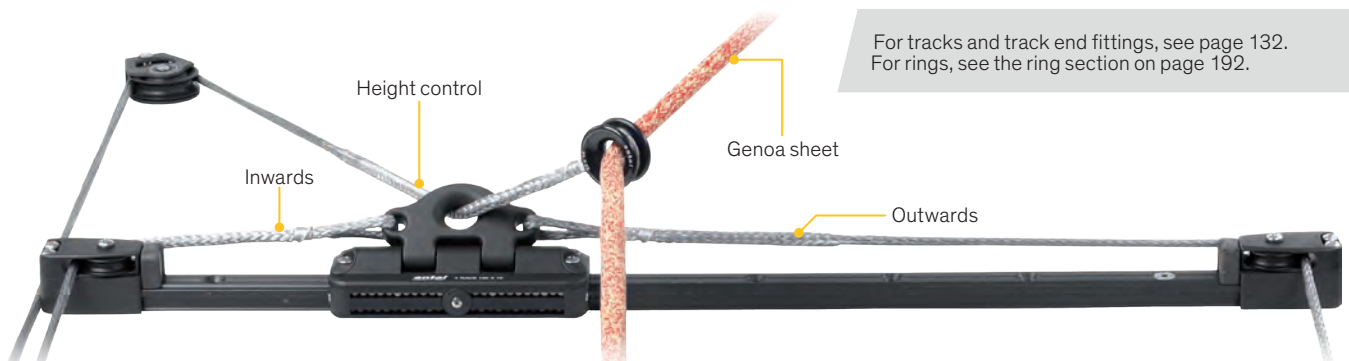

For tracks and track end fittings, see page 132.
For rings, see the ring section on page 192.

CARS FOR MAINSHEET

A Loooper block, size 80 or 100, for the mainsheet in the centre and two smaller side blocks, size 60, for the car control are linked by Dyneema™ snap-loops to a size 190 or 230 ball bearing car.

This solution, with **SWL – 1900 / 2400 kg** is suitable for boats up to 48/50 ft.

For looper blocks, see page 80. For Dyneema™ snap-loop, see page 199. For tracks and accessories, see page 132. For Soft Links and accessories, see page 185.

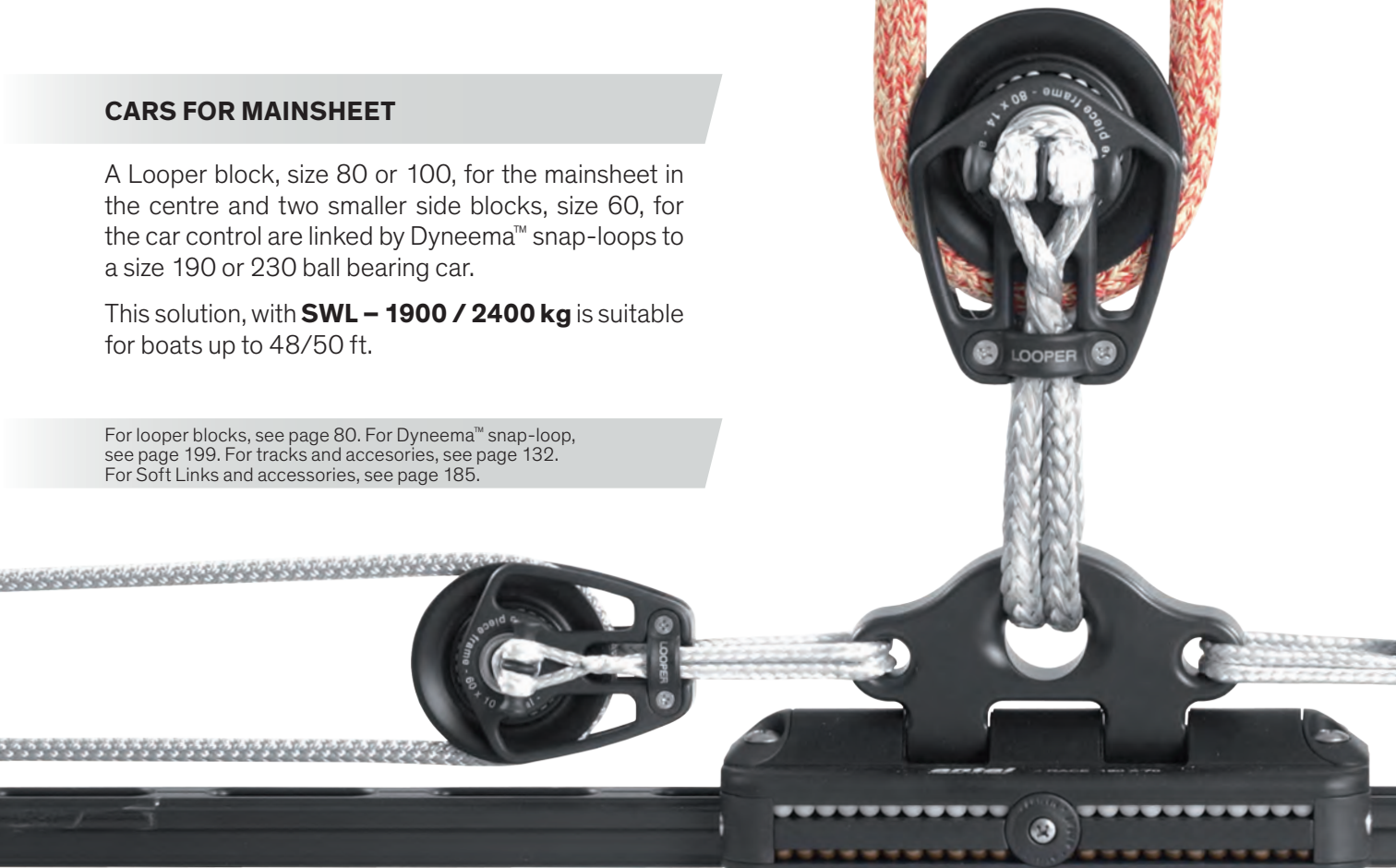

→ For larger boats up to 60 ft and **SWL up to 3800 kg**, two cars can be linked together.

Two Loooper blocks, size 80, for the sheet and two Loooper blocks, size 60, for car control complete this double 190 mm car.



→ Custom solution with two extra-long cars (2×230 mm) and **SWL – 4800 kg**.

Two Loooper blocks, size 100, for the mainsheet and two Loooper blocks, size 70, for the side control, complete this solution designed for a 65 ft boat.



GENOA CARS

SIZES 160-190-260



TRACK 31x21
Page 132

SIZE 160

For boats up to 42 ft

This 160 mm long traveller (SWL – 1400 kg) is fitted with one 60 mm sheave, for the genoa sheet, and two 45 mm sheaves for the car control.

All these sheaves are made of high strength resin with a double side ball bearing.

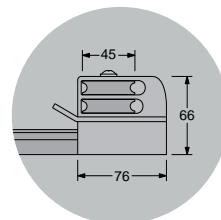

MOD. 4274G
End fitting, 2 sheaves
(D = 45 mm) and becket

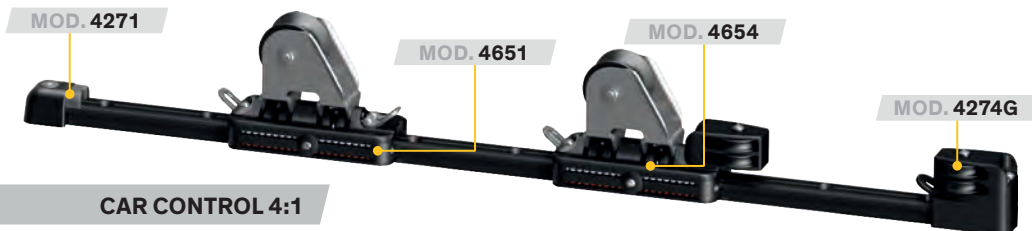

SIZE 190

For boats up to 48 ft

This 190 mm long traveller (SWL – 1900 kg) is fitted with one 75 mm aluminium sheave with Composite Fibre main bearing for the genoa sheet, and two 55 mm resin sheaves for the car control.

All these sheaves are made with a double side ball bearing.

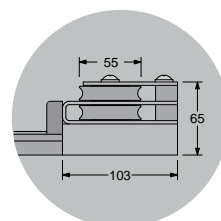

MOD. 4274Z
End fitting, 2 sheaves
(D = 55 mm) and becket

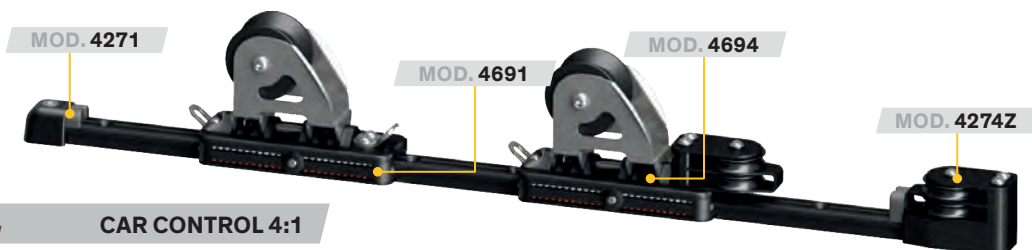

SIZE 260

For boats up to 52 ft

This 260 mm long traveller (SWL – 2800 kg) is fitted with one 75 mm aluminium sheave with Composite Fibre main bearing for the genoa sheet, and one 55 mm resin sheave for the car control.

All these sheaves are made with a double side ball bearing.

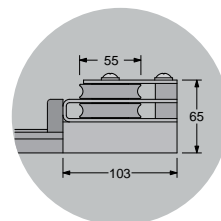

MOD. 4274Z
End fitting, 2 sheaves
(D = 55 mm) and becket



MOD. 4291 Systems of this page may be completed with the adjustable stop-pin **MOD. 4291** (only with track **MOD. 4520**).



TRANSVERSE

GENOA CAR

MOD. 4150C
TRANSVERSE GENOA CAR

 For boats up to **50 ft**

This 150 mm long traveller (SWL – 1400 kg) is fitted with two high-load Ø20 mm sheaves and one integrated side ring for a 2:1 control to move the car inward. It moves outwards automatically.

WEIGHT – 0.80 kg

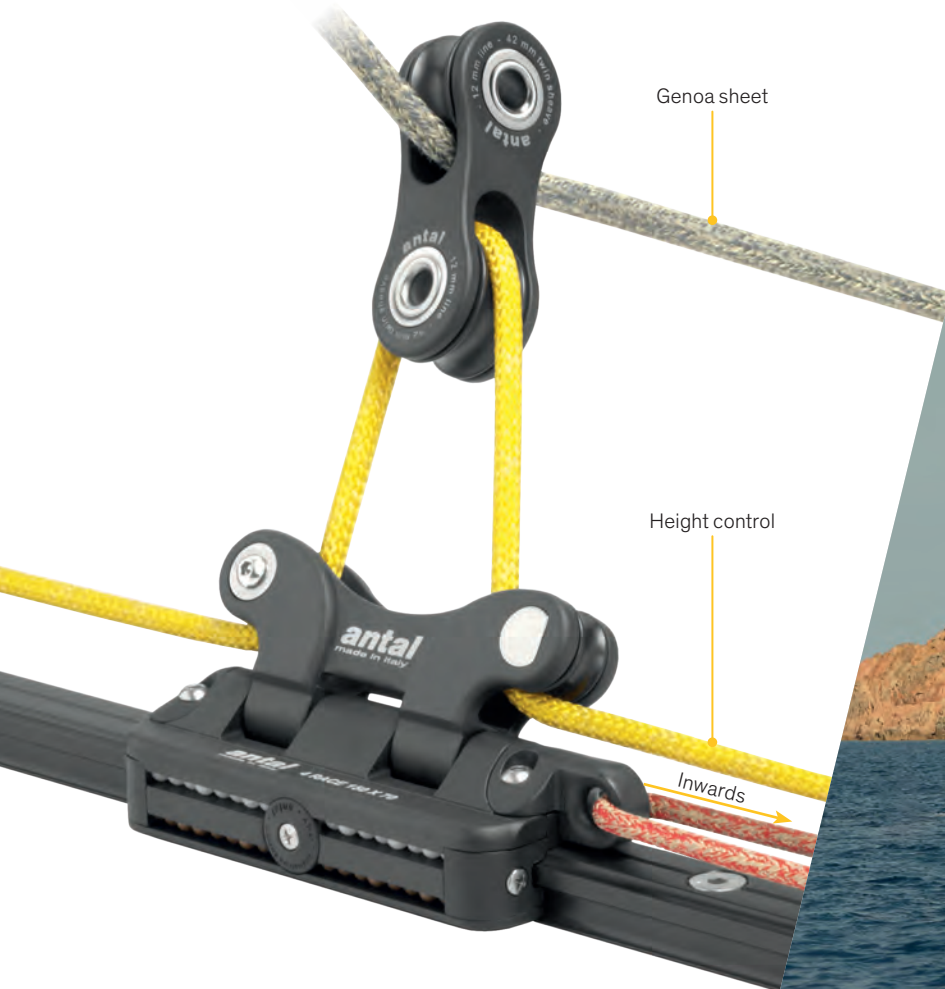

Nautor, Club Swan 50

MOD. TB4212

Page 107

- 1** → **SHEET BLOCK**
Ø42 mm sheave
for 12 mm line.

MOD. BB4012

Page 106-107

- 2** → **SNATCH BLOCK**
40 mm sheave
for 12 mm line.

MOD. BB6014

Page 106-107

- 2** → **SNATCH BLOCK**
60 mm sheave
for 14 mm line.



CURVED TRACK

MINIMUM VERTICAL RADIUS

- Acceptable
- Acceptable but with a reduction of the working load
- R** → Vertical radius

CAR SIZE mm	VERTICAL BENDING – R m									
	2	4	6	8	10	12	14	16	18	20
110				Acceptable	Acceptable	Acceptable	Acceptable	Acceptable	Acceptable	Acceptable
150				Acceptable but only for a modified car	Acceptable but only for a modified car	Acceptable but only for a modified car	Acceptable	Acceptable	Acceptable	Acceptable
190				Acceptable but only for a modified car	Acceptable but only for a modified car	Acceptable but only for a modified car	Acceptable but only for a modified car	Acceptable but only for a modified car	Acceptable	Acceptable

MINIMUM HORIZONTAL RADIUS

- Acceptable
- Acceptable but only for a modified car
- R** → Horizontal radius

CAR SIZE mm	HORIZONTAL BENDING – R m									
	2	4	6	8	10	12	14	16	18	20
110				Acceptable	Acceptable	Acceptable	Acceptable	Acceptable	Acceptable	Acceptable
150				Acceptable but only for a modified car	Acceptable but only for a modified car	Acceptable but only for a modified car	Acceptable	Acceptable	Acceptable	Acceptable
190				Acceptable but only for a modified car	Acceptable but only for a modified car	Acceptable but only for a modified car	Acceptable but only for a modified car	Acceptable but only for a modified car	Acceptable	Acceptable

MAXIMUM BENDING (MINIMUM RADIUS) FOR ANTAL TRACKS

On request Antal will supply bent tracks whether in the vertical or in the horizontal plane. Minimum radius for different lengths of the car: 110, 150 and 190 mm are quoted on the tables.



Horizontally curved track with a size 110 car.

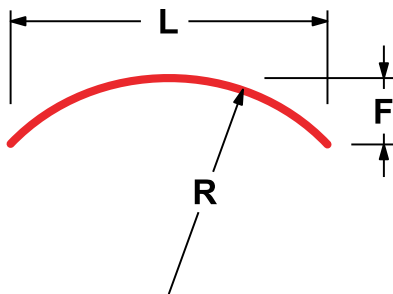

To find the value of the curved radius start from the length (**L**) and height (**F**) of the arch using the following approximate formula (**R**, **L** and **F** will be measured with the same unit of length).

$$R = \frac{L^2}{8 \cdot F} \qquad F = \frac{L^2}{8 \cdot R}$$



MOD. JB06

MOD. JB08

MOD. JB10

SELF-TACKING JIB BOARDS

5 hard black anodized aluminium models for webbing connection to the sail.

There are 4/5 different positions for the sheet block that will be simply fixed with an HR shackle.

SELF-TACKING SYSTEMS

SELF-TACKING SYSTEMS

Antal has two solutions for self-tacking using track and travellers of the new 4Race system.

1
The first solution needs a "footblock" for the sheet on one side of the track; the sheet, from this footblock, goes to the cockpit. In this case the track will be curved only in the horizontal plane.

2 3
In the second solution the sheet climbs up the mast then down and to the cockpit as a halyard. In this case the track will be curved vertically and trimmed forward.

Travellers with one or two sheet blocks will be used. Double cars are often considered because a shorter car accepts a smaller radius. To control the traveller moving it will be useful to consider also two side stop-pins (**MOD. 4291**) and consequently the track for stop-pin (**MOD. 4520**).

Systems of drawings 1 and 2 are obtained with 2×110 mm travellers and 2×70 mm blocks (for boats up to 50 ft), or 2×150 mm travellers and 2×80 mm blocks (for boats over 50 ft).



MODEL	R mm	SWL kg	WEIGHT kg	A x B kg	SHACKLE HR mm
JB06	110	1000	0.10	6×18	6
JB08	150	1800	0.25	7×20	8
JB10	210	3000	0.60	7×24	10
JB12	270	5000	1.60	8×40	12
JB14	385	7000	3.85	12×50	14

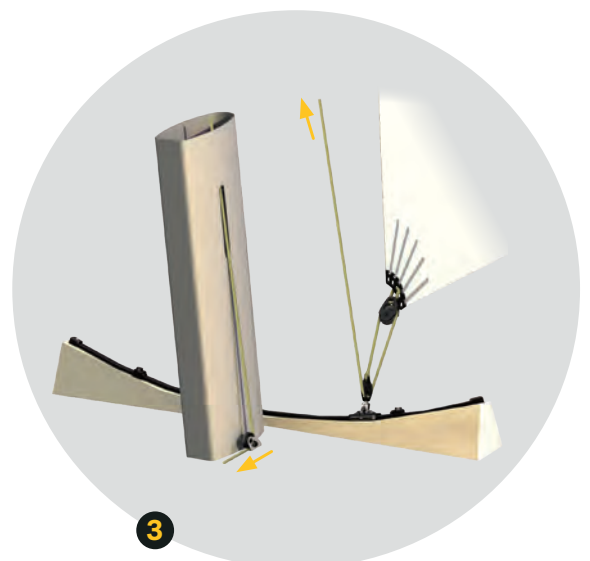
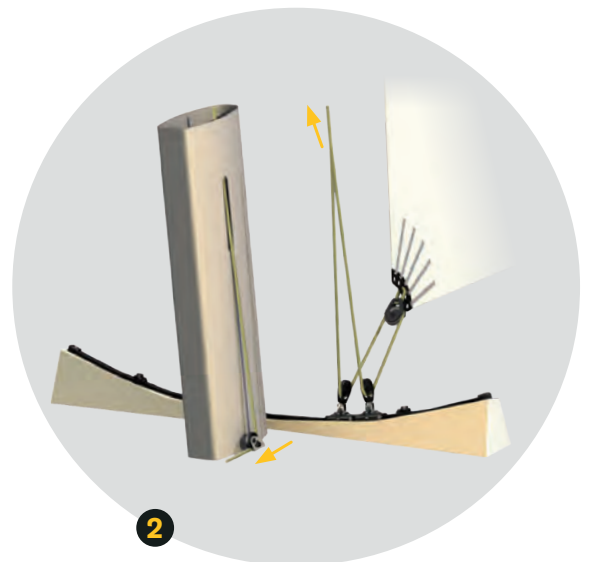
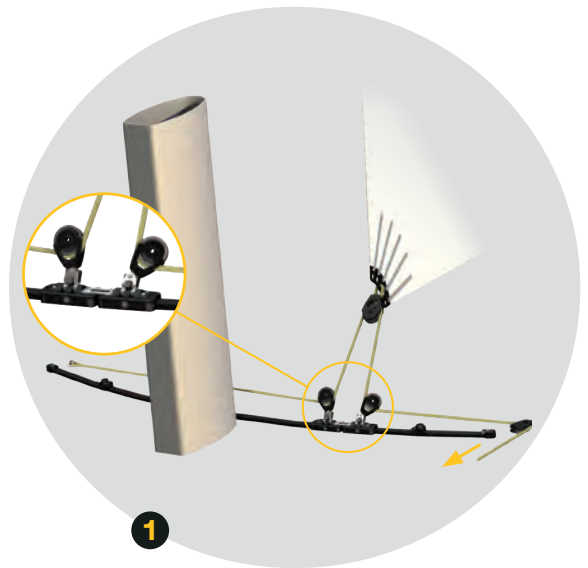

MAXI 47

SIZES 230-330-430



TRACK 47x31.5

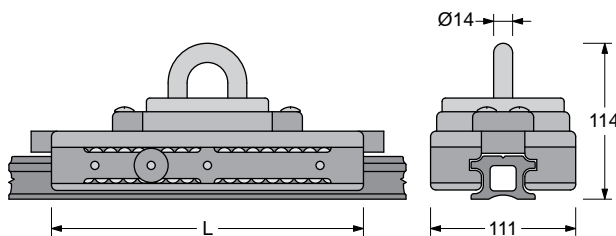

TRAVELLER LOAD AND SIZE				
MODEL	L mm	SWL kg	WEIGHT kg	N° BALLS
614.219	234	3800	2.10	86 Delrin + 86 Torlon
614.229	334	5800	3.00	124 Delrin + 124 Torlon
614.239	434	7200	3.90	162 Delrin + 162 Torlon

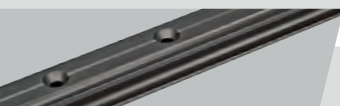

MOD. 601.123 → MAXI TRACK 47

Hard black anodized light alloy extrusion (WEIGHT – 1.8 kg/m),
FASTENERS – 10 mm screws / SPACING – 100 mm



MOD. 601.123R → MAXI 47 RACE VERSION

As the previous one with lightening holes.
WEIGHT – 1.15 kg/m



MOD. 601.223 → MAXI 47 WITH STOP-PIN HOLES

As the above Maxi track 47 with stop-pin holes.

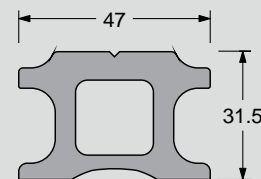

MOD. 691.822 → DOUBLE ADJUSTABLE STOP-PIN

Special double stop-pin with two independent "screw pins" (distance
50 mm). Only for track MOD. 601.223.

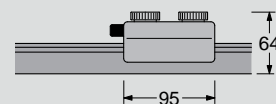

MOD. 691.560 → SIMPLE END FITTING

Hard black anodized aluminium base with shock proof rubber.
WEIGHT – 0.40 kg / FASTENERS – 2xØ10 mm screws

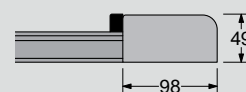

MOD. 691.561 → END FITTING WITH ONE SHEAVE

Hard black anodized aluminium base, one D = 75 mm sheave,
one becket and shock proof rubber.
WEIGHT – 0.90 kg / FASTENERS – 2xØ10 mm screws

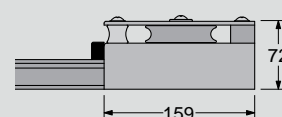

MOD. 691.563 → END FITTING WITH TWO SHEAVES

Hard black anodized aluminium base, two D = 75 mm sheave,
one becket and shock proof rubber.
WEIGHT – 1.05 kg / FASTENERS – 2xØ10 mm screws

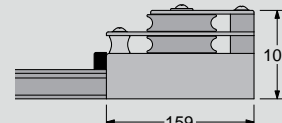

MAXI 47

SIZE 230



TRACK 47x31.5
Page 146

MAINSHEET SYSTEM, MAXI 47 TRACK – SIZE 230 TRAVELLER

For boats up to **60 ft**

One 120 mm block, OPF series, is fitted with a padeye and spring on the car for the mainsheet; one or two 75 mm sheaves for the car control. Car control 2:1, 3:1 and 4:1 are shown below.

SWL – 3800 kg

CAR CONTROL 2:1

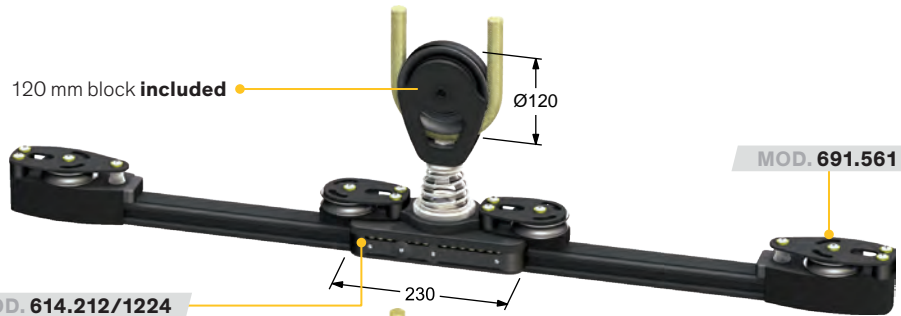

CAR CONTROL 3:1

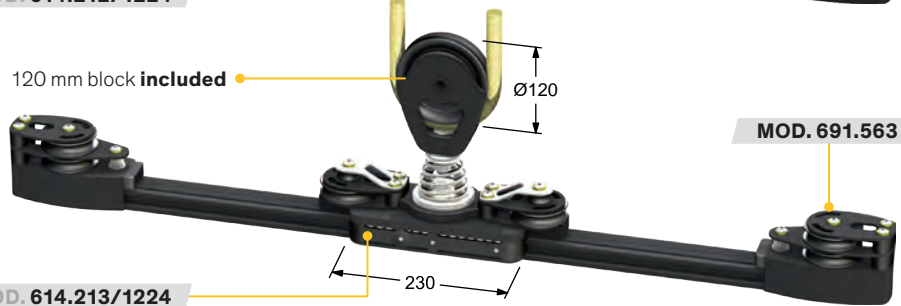

CAR CONTROL 4:1



SELF-TACKING SOLUTION

On the maxi 47 track there is a 230 mm with 2 blocks size 100 mm (OPF series).

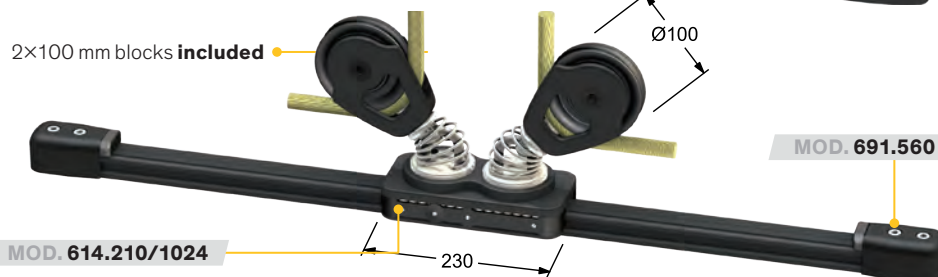

All the cars on this page are also available without the sheet block and with a simple pad-eye. To order this version, just end the model code before the / (for example, MOD. 614.212).

Neel Trimarans 51 – Ph. O. Blanchet

MAXI 47

SIZE 330



TRACK 47x31.5
Page 146

MAINSHEET SYSTEM, MAXI 47 TRACK – SIZE 330 TRAVELLER

For boats up to **70 ft**

1x140 or 2x120 mm blocks (OPF series) are fitted with a padeye and spring on the car for the mainsheet; one or two 75 mm sheaves for the car control. Car control 2:1 and 3:1 are shown below.

SWL – 5800 kg

CAR CONTROL 2:1



CAR CONTROL 3:1

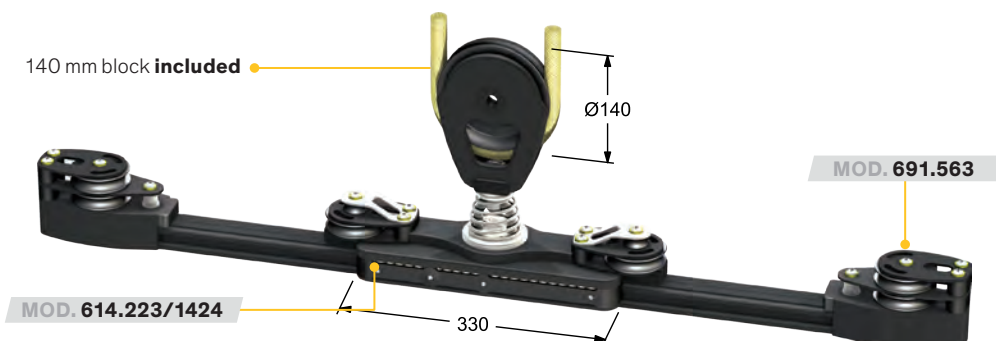

CAR CONTROL 2:1

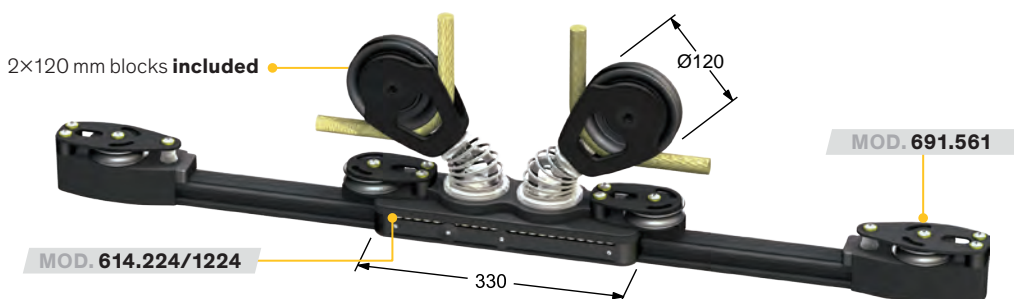

CAR CONTROL 3:1

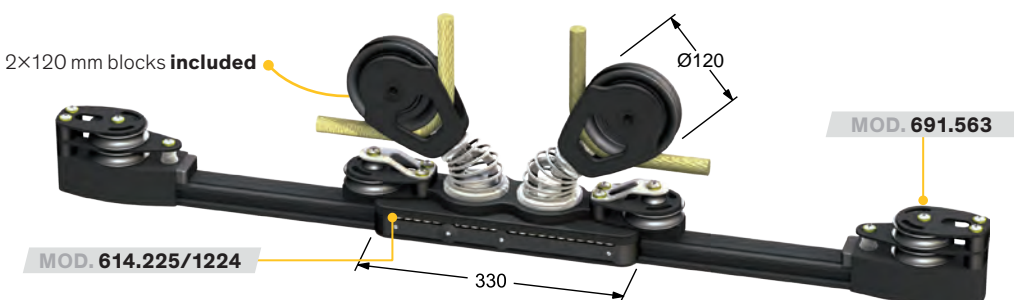

All the cars on this page are also available without the sheet block and with a simple pad-eye. To order this version, just end the model code before the / (for example, MOD. 614.222).

MAXI 47

SIZE 430



TRACK 47x31.5
Page 146

MAINSHEET SYSTEM, MAXI 47 TRACK – SIZE 430 TRAVELLER

For boats up to **80 ft**

2x120 or 3x120 mm blocks (OPF series) are fitted with a padeye and spring on the car for the mainsheet; one or two 75 mm sheaves for the car control. Car control 2:1 and 3:1 are shown below.

SWL – 7200 kg

CAR CONTROL 2:1

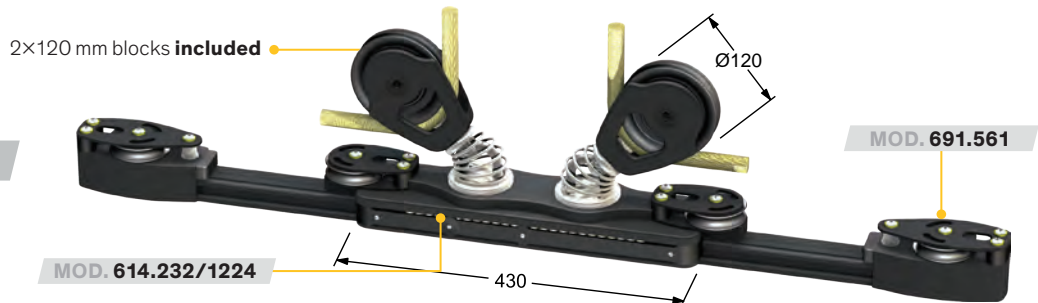

CAR CONTROL 3:1

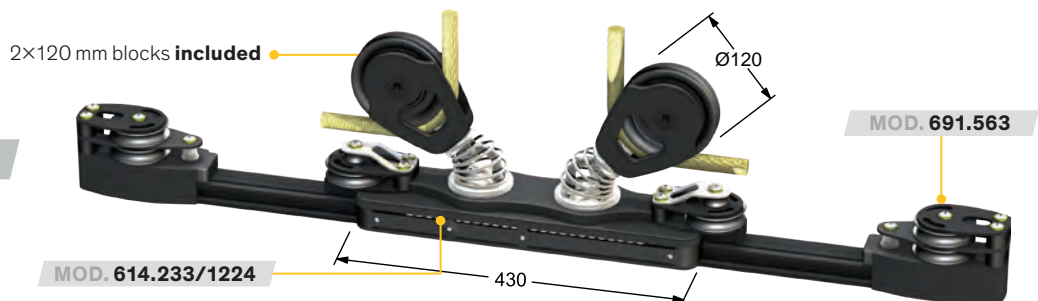

CAR CONTROL 2:1



CAR CONTROL 3:1



All the cars on this page are also available without the sheet block and with a simple pad-eye. To order this version, just end the model code before the / (for example, MOD. 614.232).

MAXI 67

SIZE 330-430-530

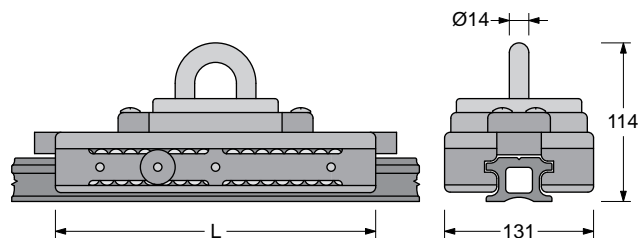

TRAVELLER LOAD AND SIZE				
MODEL	L mm	SWL kg	WEIGHT kg	N° BALLS
615.229	334	5800	4.30	124 Delrin + 124 Torlon
615.239	434	7200	5.50	162 Delrin + 162 Torlon
615.249	534	9000	6.80	206 Delrin + 206 Torlon

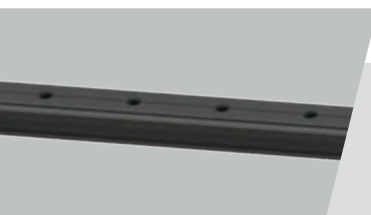

MOD. 601.124 → MAXI TRACK 67

Hard black anodized light alloy extrusion.

WEIGHT – 2.4 kg/m
FASTENERS – 12 mm screws
SPACING – 100 mm

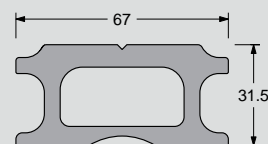

MOD. 691.660 → SIMPLE END FITTING

Hard black anodized aluminium base with shock proof rubber.

WEIGHT – 0.60 kg
FASTENERS – 2xØ12 mm screws

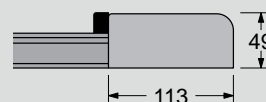

MOD. 691.661 → END FITTING WITH ONE SHEAVE

Hard black anodized aluminium base, one D = 100 mm sheave (OPF series p. 71), one becket and shock proof rubber.

WEIGHT – 1.30 kg
FASTENERS – 2xØ10 mm screws

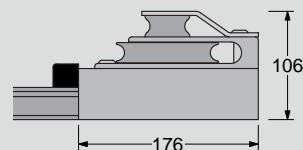

MOD. 691.663 → END FITTING WITH TWO SHEAVES

Hard black anodized aluminium base, two D = 100 mm sheave (OPF series p. 71), one becket and shock proof rubber.

WEIGHT – 1.50 kg
FASTENERS – 2xØ10 mm screws

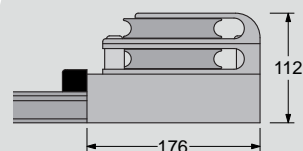

→ CUSTOM MODEL

Two cars 330 mm long and two blocks 150 mm diameter. **SWL – 2x5800 kg.**

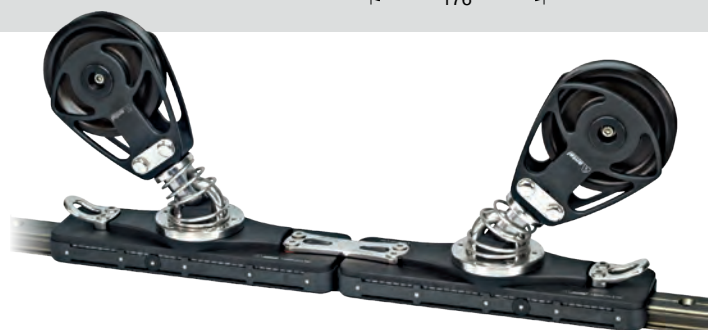

MAINSHEET SYSTEM, MAXI 67 TRACK – SIZE 330-430 TRAVELLER



D = 140 mm or D = 120 mm blocks (OPF series) can be fitted with a padeye and spring on the car for the mainsheet; two D = 100 mm sheaves for the car control. Car control 2:1 and 3:1 are shown below.

SWL – 5800 / 7200 kg



All the cars on this page are also available without the sheet block and with a simple pad-eye. To order this version, just end the model code before the / (for example **MOD. 615.222**).

ANTAL FOR MAXI YACHTS

 4RACE

 TRACK 67x31.5
Page 150

MOD. 911.254 → BLOCK

250 mm block on Composite Fibre bushing and 2 side ball bearings.

WEIGHT – 14.35 kg

SWL – 20000 kg

FOR BOATS OVER 150 FT

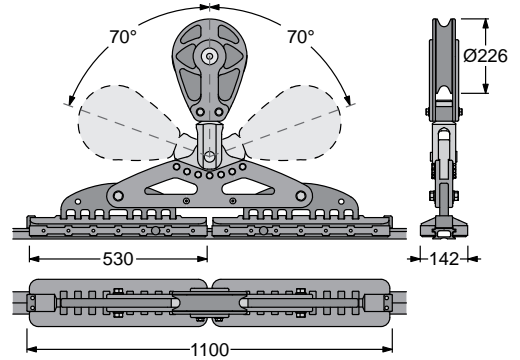

TRAVELLERS

2x530 mm long, hard black anodized aluminium one-piece body on Torton ball bearings **Antal 4Race** system (each traveller works on 424 balls).

WEIGHT – 26 kg

SWL – 18000 kg



LIFE RAIL SYSTEM



SAFETY DEVICE FOR OUTBOARD CLEANING AND MAINTENANCE



LRS is in conformity with **EN795:2012 type D**.

The operator (using a suitable harness) is tied to a double traveller that slides horizontally on the rail and is free to reach the working area in perfect safety.

The double traveller is fitted with two shackles and a stop-pin:

- stop-pin **open**: it allows the traveller to slide along the whole track;
- stop-pin **closed**: it locks the traveller when it intercepts the first hole in the rail.

Other travellers (without any stop-pin) can be connected to the main traveller for further security and for carrying tools or any other material (bosun's chair, etc.).



More information in the LRS user's guide available on request.

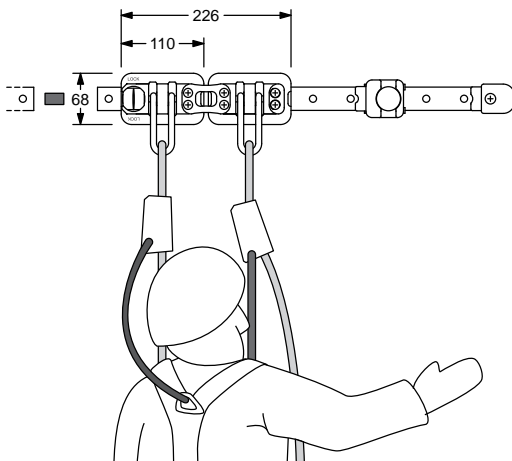

The system consists of:

MOD. 4523

Tubular track (31x21 mm) in high resistance hard black (silver on request) anodized extruded aluminium, Ø8 mm fixing screws every 100 mm, holes to stop the traveller every 50 mm, weight 0.75 kg/m, available in 3 m lengths.

MOD. 4271B

Aluminium end-fitting with rubber protection

MOD. 4291

Aluminium stop-pin on Nylon guides.

MOD. 4283

Track joint, aluminium made. Track joint is supplied with two screws.

MOD. 4118

Hard black anodized aluminium double traveller (2x110 mm). The traveller slides on four circuits of Torlon balls and its hold is guaranteed even in the event of the balls failing. Two AISI316 steel shackles with 180° rotation.

MOD. 4119SP

The car with the stop-pin is also available individually.



The track can be fixed both on a horizontal surface and on a vertical wall.

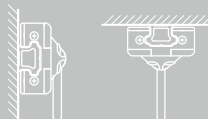



FULL BATTEN

MAINSAIL SYSTEMS



HS guide systems 156



Fibreball systems 165



Special products 178



Batten receptacles 180



Hook carriages 182

FULL BATTEN SYSTEM: 6 different tracks and 14 slider systems, a wide and complete range for full-batten mainsails, for boats from 30 to 100 ft and for multihulls.

HS GUIDE SYSTEMS: a simple and efficient solution with minimum sizes for very high loads, designed for racing. The HS guide systems have been developed also for cruising and charter boats.

FIBREBALL SYSTEMS: designed for large boats and for mainsails with a large roach, they offer the high strength of HS Fibre Guides (for tension load) and the low friction of the Torlon ball bearing (for compression).

HS GUIDE SYSTEMS

FULL BATTEN

The Antal **HS Guide System** is designed for boats with **Full Batten mainsails** that experience high loads and compression-loading on the mainsail luff. The system's aluminium sliders contain HS Composite Fibre inserts that run on aluminium track mounted on the mast. **HS Composite Fibre** is a new material that is durable over long periods of use and offers extremely low friction coefficients. The material is made from special resins strengthened with fibre and is self lubricating.

The HS guide system provides the following advantages:

- the low friction properties of the HS Composite Fibre allows the cars to be shorter than standard ball-bearing car systems, thereby **reducing the stacking height** at the mast when the sail is down;
- the lower **cars can easily be removed** from the track when the sail is reefed, thereby keeping the

tack low to the boom;

- **minimum friction** under load;
- **less maintenance** than ball bearing car systems;
- **cars can easily be removed** and re-installed on the track whenever the mainsail is changed.

Each batten end fitting is attached to a slider with a triaxial joint to ensure that the batten can freely orient itself under all points of sail. At least one simple slider should be attached to the sail with Nylon webbing between two battens. A headboard is attached to the sail with webbing and is secured to the slider (double or triple) with a clevis pin which allows the headboard to pivot and to be removed.



TRACK		SYSTEM	FOR BOATS UP TO ft	PAGE
HS22		HS22.40	40'	159
		HS22.50R	50' (Racing)	160
		HS22.60R	60' (Racing)	161
HS24		HS24.50	50'	162
		HS24.60	60'	163
		HS24.70	70'	164
HS30		HS30.90	80'	165
		HS30.130	100'	166

HS22.40

HS22 TRACK, 40^{MM} SLIDERS



TRACK 22x11
Page 172-173

FOR BOATS UP TO 40 FT

MOD. HS22.40D

HEADBOARD SLIDERS
LENGTH – 130 mm
WEIGHT – 0.19 kg
SWL – 700 kg (horizontal)



HS22.40 system sliders
run on inserts made
of self-lubricating resin.

MOD. HS22.40S

SIMPLE SLIDER
LENGTH – 40 mm
WEIGHT – 0.04 kg
SWL – 350 kg (horizontal)
WEBBING – 16 mm

MOD. HS22.40J

SLIDER WITH JOINT
LENGTH – 40 mm
WEIGHT – 0.07 kg
SWL – 350 kg (horizontal)
THREADED PIN – M10

SYSTEM HS22.40R

→ For racing boats up to 40 ft

As system HS22.40, but with sliders on HS fiber
guides instead of resin guides (R).

MOD. HS22.40DR HEADBOARD SLIDERS

MOD. HS22.40SR SIMPLE SLIDER

MOD. HS22.40JR SLIDER WITH JOINT

MOD. HS22.44

HEADBOARD 40°
HEIGHT – 122 mm
WIDTH – 126 mm
WEIGHT – 0.11 kg
SWL – 1300 kg (vertical)
WEBBING – 20 mm

MOD. HS22.46

HEADBOARD 60°
HEIGHT – 122 mm
WIDTH – 145 mm
WEIGHT – 0.12 kg
SWL – 1300 kg (vertical)
WEBBING – 20 mm

MOD. HS22.49

HEADBOARD 90°
HEIGHT – 118 mm
WIDTH – 100 mm
WEIGHT – 0.09 kg
SWL – 1300 kg (vertical)
WEBBING – 20 mm

MOD. 609.320

SBR RECEPTACLE
on page 178

MOD. HS22.70JAR

**ASYMMETRIC SLIDER
WITH JOINT**

For inclined battens of
top-square sails.

LENGTH – 70 mm
WEIGHT – 0.15 kg
SWL – 600 kg
THREADED PIN – M10

70

HS22.50R

HS22 TRACK, 50^{MM} SLIDERS



TRACK 22x11
Page 172-173

FOR ~50 FT RACING BOATS

MOD. HS22.50DR

HEADBOARD SLIDERS

LENGTH – 150 mm
WEIGHT – 0.33 kg
SWL – 1600 kg (horizontal)

MOD. HS22.50SR

SIMPLE SLIDER

LENGTH – 50 mm
WEIGHT – 0.08 kg
SWL – 800 kg (horizontal)
WEBBING – 18 mm

MOD. HS22.70JR

SLIDER WITH JOINT TOP BATTEN

LENGTH – 70 mm
WEIGHT – 0.23 kg
SWL – 1300 kg (horizontal)
THREADED PIN – M12
Smaller thread sizes
available on request.

MOD. HS22.50SR

MOD. HS22.50JR

SLIDER WITH JOINT LOWER BATTEN

LENGTH – 50 mm
WEIGHT – 0.14 kg
SWL – 800 kg (horizontal)
THREADED PIN – M10

MOD. HS24.54

HEADBOARD 40°

HEIGHT – 136 mm
WIDTH – 147 mm
WEIGHT – 0.19 kg
SWL – 2000 kg (vertical)
WEBBING – 25 mm

MOD. HS24.56

HEADBOARD 60°

HEIGHT – 136 mm
WIDTH – 182 mm
WEIGHT – 0.25 kg
SWL – 2000 kg (vertical)
WEBBING – 25 mm

MOD. HS24.59

HEADBOARD 90°

HEIGHT – 146 mm
WIDTH – 120 mm
WEIGHT – 0.18 kg
SWL – 2000 kg (vertical)
WEBBING – 25 mm

MOD. HS22.100JAR

ASYMMETRIC SLIDER WITH JOINT

For inclined battens
of top-square sails.

LENGTH – 100 mm
WEIGHT – 0.32 kg
SWL – 1400 kg
THREADED PIN – M10

MOD. 609.321

SBR RECEPTACLE
on page 178

HS22.60R

HS22 TRACK, 60^{MM} SLIDERS



TRACK 22x11
Page 172-173

FOR ~60 FT RACING BOATS

MOD. HS22.60TR

HEADBOARD SLIDERS

LENGTH – 201 mm
WEIGHT – 0.65 kg
SWL – 2900 kg (horizontal)

MOD. HS22.50SR

SIMPLE SLIDER

LENGTH – 50 mm
WEIGHT – 0.08 kg
SWL – 800 kg (horizontal)
WEBBING – 20 mm

MOD. HS22.90JR

SLIDER WITH JOINT TOP BATTEN

LENGTH – 90 mm
WEIGHT – 0.29 kg
SWL – 1300 kg (horizontal)

THREADED PIN – M12
Smaller thread sizes
available on request.

MOD. HS22.50SR

MOD. HS22.110

OUTHAUL SLIDER

LENGTH – 110 mm
WEIGHT – 0.30 kg
SWL – 1800 kg (horizontal)
WEBBING – 25 mm

MOD. HS24.64

HEADBOARD 40°

HEIGHT – 182 mm
WIDTH – 193 mm
WEIGHT – 0.43 kg
SWL – 3500 kg (vertical)
WEBBING – 35 mm

MOD. HS24.66

HEADBOARD 60°

HEIGHT – 182 mm
WIDTH – 240 mm
WEIGHT – 0.54 kg
SWL – 3500 kg (vertical)
WEBBING – 35 mm

MOD. HS24.69

HEADBOARD 90°

HEIGHT – 180 mm
WIDTH – 142 mm
WEIGHT – 0.38 kg
SWL – 3500 kg (vertical)
WEBBING – 35 mm

MOD. 609.323

SBR RECEPTACLE
on page 179

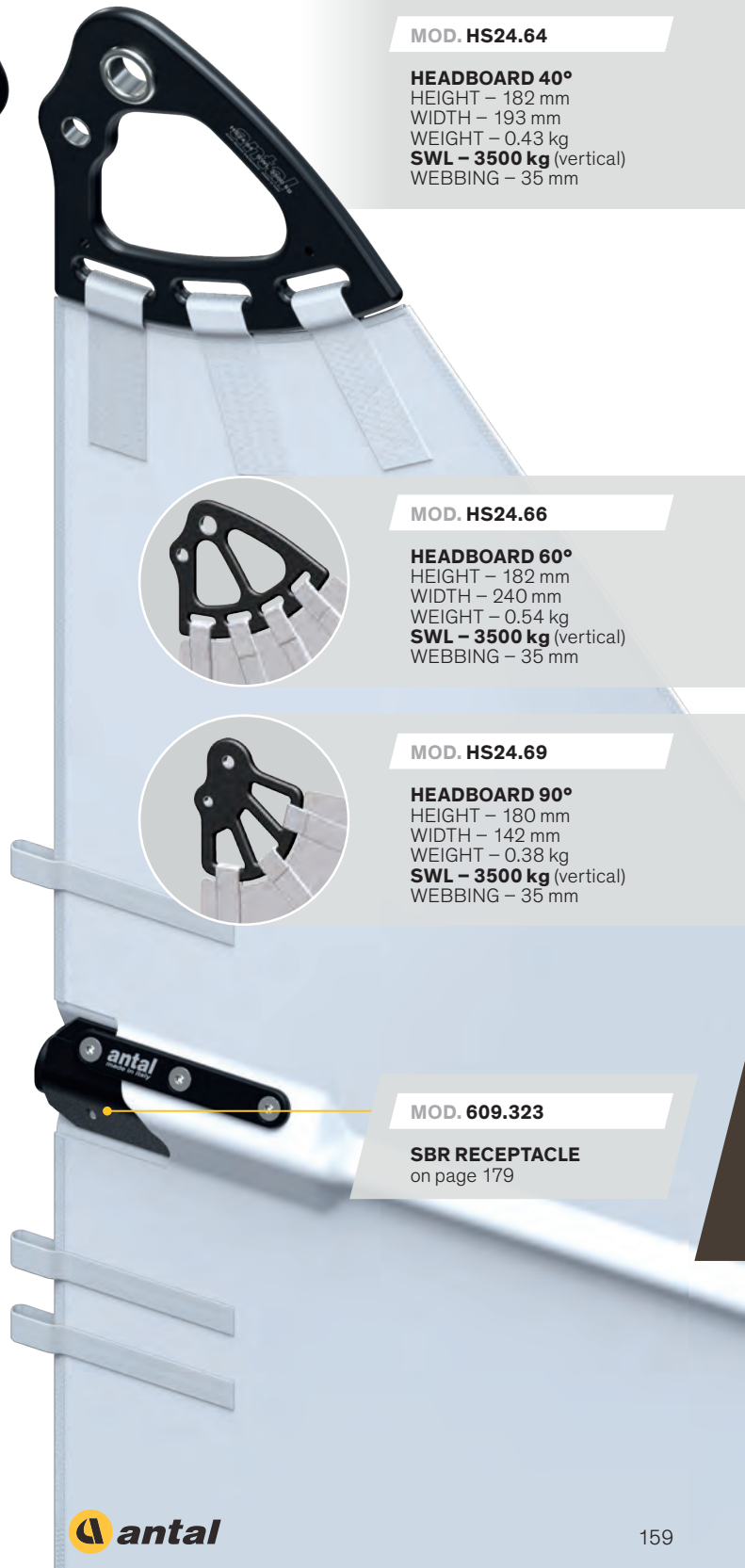

HS24.50

HS24 TRACK, 50^{MM} SLIDERS



TRACK 24x16
Page 174-175

FOR ~50 FT BOATS

MOD. HS24.50D

HEADBOARD SLIDERS

LENGTH – 150 mm
WEIGHT – 0.37 kg
SWL – 1600 kg (horizontal)

MOD. HS24.50S

SIMPLE SLIDER

LENGTH – 50 mm
WEIGHT – 0.09 kg
SWL – 800 kg (horizontal)
WEBBING – 18 mm

MOD. HS24.50J

SLIDER WITH JOINT

LENGTH – 50 mm
WEIGHT – 0.14 kg
SWL – 800 kg (horizontal)
THREADED PIN – M10

MOD. HS24.54

HEADBOARD 40°

HEIGHT – 136 mm
WIDTH – 147 mm
WEIGHT – 0.19 kg
SWL – 2000 kg (vertical)
WEBBING – 25 mm

MOD. HS24.56

HEADBOARD 60°

HEIGHT – 136 mm
WIDTH – 182 mm
WEIGHT – 0.25 kg
SWL – 2000 kg (vertical)
WEBBING – 25 mm

MOD. HS24.59

HEADBOARD 90°

HEIGHT – 146 mm
WIDTH – 120 mm
WEIGHT – 0.18 kg
SWL – 2000 kg (vertical)
WEBBING – 25 mm

MOD. HS24.110JA

ASYMMETRIC SLIDER WITH JOINT

For inclined battens of top-square sails.

LENGTH – 110 mm
WEIGHT – 0.38 kg
SWL – 1400 kg
THREADED PIN – M10

MOD. 609.321

SBR RECEPTACLE
on page 178

HS24.60

HS24 TRACK, 60^{MM} SLIDERS



TRACK 24x16
Page 174-175

FOR ~60 FT BOATS

MOD. HS24.60T

HEADBOARD SLIDERS

LENGTH – 201 mm
WEIGHT – 0.73 kg
SWL – 2900 kg (horizontal)

MOD. HS24.50S

MOD. HS24.60J

SLIDER WITH JOINT TOP BATTEN

LENGTH – 60 mm
WEIGHT – 0.21 kg
SWL – 1300 kg (horizontal)

THREADED PIN – M12
Smaller thread sizes
available on request.

MOD. HS24.50S

SIMPLE SLIDER

LENGTH – 50 mm
WEIGHT – 0.09 kg
SWL – 800 kg (horizontal)
WEBBING – 18 mm

MOD. HS24.50J

SLIDER WITH JOINT LOWER BATTEN

LENGTH – 50 mm
WEIGHT – 0.14 kg
SWL – 800 kg (horizontal)
THREADED PIN – M10

MOD. HS24.64

HEADBOARD 40°

HEIGHT – 182 mm
WIDTH – 193 mm
WEIGHT – 0.43 kg
SWL – 3500 kg (vertical)
WEBBING – 35 mm

MOD. HS24.66

HEADBOARD 60°

HEIGHT – 182 mm
WIDTH – 240 mm
WEIGHT – 0.54 kg
SWL – 3500 kg (vertical)
WEBBING – 35 mm

MOD. HS24.69

HEADBOARD 90°

HEIGHT – 180 mm
WIDTH – 142 mm
WEIGHT – 0.38 kg
SWL – 3500 kg (vertical)
WEBBING – 35 mm

MOD. 609.323

SBR RECEPTACLE
on page 179

HS24.70

HS24 TRACK, 70^{MM} SLIDERS



TRACK 24x16
Page 174-175

FOR ~70 FT BOATS

MOD. HS24.70Q

HEADBOARD SLIDERS

LENGTH – 340 mm
WEIGHT – 1.28 kg
SWL – 4500 kg (horizontal)

MOD. HS24.50S

SIMPLE SLIDER

LENGTH – 50 mm
WEIGHT – 0.09 kg
SWL – 800 kg (horizontal)
WEBBING – 18 mm

MOD. HS24.70J

SLIDER WITH JOINT TOP BATTEN

LENGTH – 70 mm
WEIGHT – 0.24 kg
SWL – 1500 kg (horizontal)

THREADED PIN – M14
Smaller thread sizes
available on request.

MOD. HS24.60J

SLIDER WITH JOINT LOWER BATTEN

LENGTH – 60 mm
WEIGHT – 0.21 kg
SWL – 1300 kg (horizontal)

THREADED PIN – M12
Smaller thread sizes
available on request.

MOD. HS24.74

HEADBOARD 40°

HEIGHT – 281 mm
WIDTH – 279 mm
THICKNESS – 12 mm
WEIGHT – 1.06 kg
SWL – 5000 kg (vertical)
WEBBING – 40 mm

MOD. HS24.76

HEADBOARD 60°

HEIGHT – 281 mm
WIDTH – 359 mm
WEIGHT – 1.18 kg
SWL – 5000 kg (vertical)
WEBBING – 40 mm

MOD. HS24.79

HEADBOARD 90°

HEIGHT – 225 mm
WIDTH – 180 mm
WEIGHT – 0.71 kg
SWL – 5000 kg (vertical)
WEBBING – 40 mm

MOD. HS24.50S

MOD. 609.325

SBR RECEPTACLE
on page 179

HS30.90

HS30 TRACK, 90/110^{MM} SLIDERS



TRACK 30x13
Page 176

FOR 80-90 FT BOATS

MOD. HS30.70Q

HEADBOARD SLIDERS
LENGTH – 340 mm
WEIGHT – 1.63 kg
SWL – 4500 kg (horizontal)

MOD. HS30.70S

SIMPLE SLIDER
LENGTH – 70 mm
WEIGHT – 0.20 kg
SWL – 1300 kg (horizontal)
WEBBING – 25 mm

MOD. HS30.110J

**SLIDER WITH JOINT
TOP BATTEN**
LENGTH – 110 mm
WEIGHT – 0.47 kg
SWL – 2200 kg (horizontal)
THREADED PIN – M14
Smaller thread sizes
available on request.

MOD. HS30.70S

MOD. HS30.90J

**SLIDER WITH JOINT
LOWER BATTEN**
LENGTH – 90 mm
WEIGHT – 0.39 kg
SWL – 1900 kg (horizontal)
THREADED PIN – M14
Smaller thread sizes
available on request.

MOD. HS30.116

OUTHAUL SLIDER
LENGTH – 116 mm
WEIGHT – 0.32 kg
SWL – 2500 kg (horizontal)
WEBBING – 2x25 mm



MOD. HS30.76

HEADBOARD 60°
HEIGHT – 281 mm
WIDTH – 359 mm
WEIGHT – 1.47 kg
SWL – 6200 kg (vertical)
WEBBING – 40 mm

MOD. HS30.74

HEADBOARD 40°
HEIGHT – 281 mm
WIDTH – 279 mm
THICKNESS – 15 mm
WEIGHT – 1.30 kg
SWL – 6200 kg (vertical)
WEBBING – 40 mm



MOD. HS30.79

HEADBOARD 90°
HEIGHT – 225 mm
WIDTH – 180 mm
WEIGHT – 0.88 kg
SWL – 6200 kg (vertical)
WEBBING – 40 mm

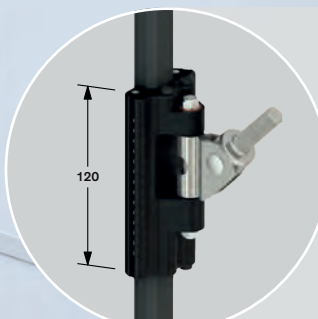

MOD. HS30.120JA

**ASYMMETRIC SLIDER
WITH JOINT**
For inclined battens
of top-square sails.
LENGTH – 120 mm
WEIGHT – 0.42 kg
SWL – 2200 kg
THREADED PIN – M14
Smaller thread sizes
available on request.

MOD. 609.325

SBR RECEPTACLE
on page 179

HS30.130

HS30 TRACK, 130^{MM} SLIDERS



TRACK 30x13
Page 176

FOR ~100 FT BOATS

MOD. HS30.90Q

HEADBOARD SLIDERS

LENGTH – 366 mm
WEIGHT – 1.88 kg
SWL – 5800 kg (horizontal)

MOD. HS30.70S

SIMPLE SLIDER

LENGTH – 70 mm
WEIGHT – 0.20 kg
SWL – 1300 kg (horizontal)
WEBBING – 25 mm

MOD. HS30.130J

SLIDER WITH JOINT

LENGTH – 130 mm
WEIGHT – 0.75 kg
SWL – 3000 kg (horizontal)

THREADED PIN – M16
Smaller thread sizes
available on request.

MOD. HS30.130J

OUTHAUL SLIDER

LENGTH – 116 mm
WEIGHT – 0.32 kg
SWL – 2500 kg (horizontal)
WEBBING – 2x25 mm

MOD. HS30.74

HEADBOARD 40°

HEIGHT – 281 mm
WIDTH – 279 mm
THICKNESS – 15 mm
WEIGHT – 1.30 kg
SWL – 6200 kg (vertical)
WEBBING – 40 mm

MOD. HS30.76

HEADBOARD 60°

HEIGHT – 281 mm
WIDTH – 359 mm
WEIGHT – 1.47 kg
SWL – 6200 kg (vertical)
WEBBING – 40 mm

MOD. HS30.79

HEADBOARD 90°

HEIGHT – 225 mm
WIDTH – 180 mm
WEIGHT – 0.88 kg
SWL – 6200 kg (vertical)
WEBBING – 40 mm

MOD. 609.326

SBR RECEPTACLE

on page 179

FIBREBALL SYSTEMS

FULL BATTEN



SELF-CAPTIVE BEARINGS

It's impossible for the bearings in the slider to come out, so it's possible to take off the sliders from the track.

Designed for large boats and for mainsails with a large roach, they offer the **high strength of HS Fibre Guides** (for tension load) and the low friction of the Torlon ball bearing (for compression).

Maximum load because the HS fibre guides give excellent resistance to the main pull loads despite the compact size of the carriages.

Each batten end fitting is attached to a slider with a triaxial joint to ensure that the batten can **freely orient** itself under all points of sail. At least one simple slider should be attached to the sail with Nylon webbing between two battens.

A headboard is attached to the sail with webbing and is secured to the slider (double) with a clevis pin which allows the headboard to pivot and to be removed.



TRACK	SYSTEM	FOR BOATS UP TO ft	PAGE
HS24 	FB24.60	50'	168
	FB24.90	60'	169
	FB24.120	70'	170
FB32 	FB32.160	100'	171



FB24.60

HS24 TRACK, 60^{MM} SLIDERS



TRACK 24x16
Page 174-175

FOR ~50 FT BOATS

MOD. FB24.60D

HEADBOARD SLIDERS

LENGTH – 160 mm
WEIGHT – 0.30 kg
SWL – 1600 kg (horizontal)

MOD. FB24.60S

SIMPLE SLIDER

LENGTH – 60 mm
WEIGHT – 0.12 kg
SWL – 800 kg (horizontal)
WEBBING – 18 mm

MOD. FB24.60J

SLIDER WITH JOINT

LENGTH – 60 mm
WEIGHT – 0.16 kg
SWL – 800 kg (horizontal)
THREADED PIN – M10

MOD. HS24.54

HEADBOARD 40°

HEIGHT – 136 mm
WIDTH – 147 mm
WEIGHT – 0.19 kg
SWL – 2000 kg (vertical)
WEBBING – 25 mm

MOD. HS24.56

HEADBOARD 60°

HEIGHT – 136 mm
WIDTH – 182 mm
WEIGHT – 0.25 kg
SWL – 2000 kg (vertical)
WEBBING – 25 mm

MOD. HS24.59

HEADBOARD 90°

HEIGHT – 146 mm
WIDTH – 120 mm
WEIGHT – 0.18 kg
SWL – 2000 kg (vertical)
WEBBING – 25 mm

→ SELF-CAPTIVE BALLS

MOD. 609.321

SBR RECEPTACLE
on page 178

FB24.90

HS24 TRACK, 90^{MM} SLIDERS



TRACK 24x16
Page 174-175

FOR ~60 FT BOATS

MOD. FB24.90D

HEADBOARD SLIDERS
LENGTH – 240 mm
WEIGHT – 0.50 kg
SWL – 2600 kg (horizontal)

MOD. FB24.60S

SIMPLE SLIDER
LENGTH – 60 mm
WEIGHT – 0.12 kg
SWL – 800 kg (horizontal)
WEBBING – 18 mm

MOD. FB24.90J

SLIDER WITH JOINT
LENGTH – 90 mm
WEIGHT – 0.24 kg
SWL – 1300 kg (horizontal)
THREADED PIN – M12
Smaller thread sizes
available on request.

MOD. FB24.121

OUTHAUL SLIDER
LENGTH – 120 mm
WEIGHT – 0.24 kg
SWL – 1600 kg (horizontal)
WEBBING – 2x18 mm



MOD. HS24.66

HEADBOARD 60°
HEIGHT – 182 mm
WIDTH – 240 mm
WEIGHT – 0.54 kg
SWL – 3500 kg (vertical)
WEBBING – 35 mm



MOD. HS24.64

HEADBOARD 40°
HEIGHT – 182 mm
WIDTH – 193 mm
WEIGHT – 0.43 kg
SWL – 3500 kg (vertical)
WEBBING – 35 mm



MOD. HS24.69

HEADBOARD 90°
HEIGHT – 180 mm
WIDTH – 142 mm
WEIGHT – 0.38 kg
SWL – 3500 kg (vertical)
WEBBING – 35 mm

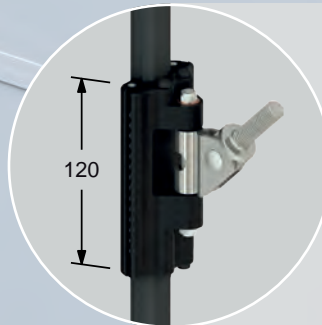

MOD. FB24.120JA

ASYMMETRIC SLIDER WITH JOINT
For inclined battens of top-square sails.
LENGTH – 120 mm
WEIGHT – 0.40 kg
SWL – 1400 kg
THREADED PIN – M12
Smaller thread sizes
available on request.



MOD. 609.323

SBR RECEPTACLE
on page 179

FB24.120

HS24 TRACK, 120^{MM} SLIDERS



TRACK 24x16
Page 174-175

FOR ~70 FT BOATS

MOD. FB24.120D

HEADBOARD SLIDERS

LENGTH – 340 mm
WEIGHT – 0.90 kg
SWL – 3200 kg (horizontal)

MOD. FB24.60S

SIMPLE SLIDER

LENGTH – 60 mm
WEIGHT – 0.12 kg
SWL – 800 kg (horizontal)
WEBBING – 18 mm

MOD. FB24.120J

SLIDER WITH JOINT

LENGTH – 120 mm
WEIGHT – 0.36 kg
SWL – 1600 kg (horizontal)

THREADED PIN – M14
Smaller thread sizes
available on request.

MOD. FB24.121

OUTHAUL SLIDER

LENGTH – 120 mm
WEIGHT – 0.24 kg
SWL – 1600 kg (horizontal)
WEBBING – 2x18 mm

MOD. HS24.74

HEADBOARD 40°

HEIGHT – 281 mm
WIDTH – 279 mm
THICKNESS – 12 mm
WEIGHT – 1.06 kg
SWL – 5000 kg (vertical)
WEBBING – 40 mm

MOD. HS24.76

HEADBOARD 60°

HEIGHT – 281 mm
WIDTH – 359 mm
WEIGHT – 1.18 kg
SWL – 5000 kg (vertical)
WEBBING – 40 mm

MOD. HS24.79

HEADBOARD 90°

HEIGHT – 225 mm
WIDTH – 180 mm
WEIGHT – 0.71 kg
SWL – 5000 kg (vertical)
WEBBING – 40 mm

MOD. 609.325

SBR RECEPTACLE
on page 179

→ SELF-CAPTIVE BALLS

FB32.160 NEW

FB32 TRACK, 160^{MM} SLIDERS



TRACK 32x20
Page 177

FOR ~100 FT BOATS

MOD. FB32.160D

HEAD CARRIAGE
LENGTH – 366 mm
WEIGHT – 2.20 gr
SWL – 5000 kg

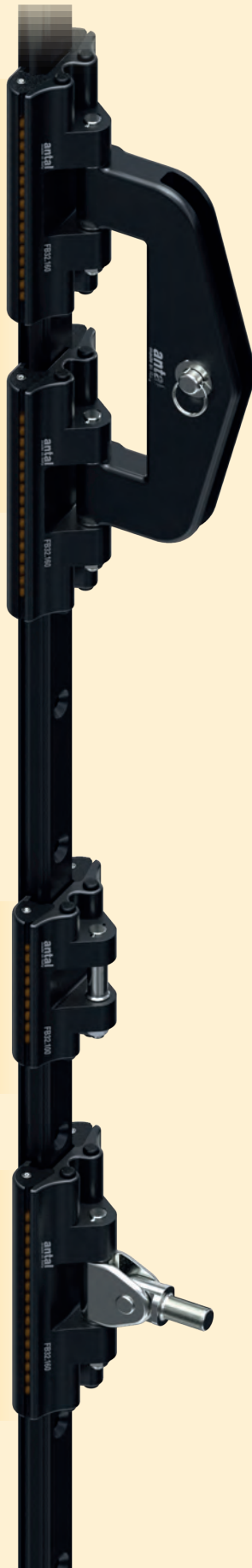

MOD. HS30.74

HEADBOARD 40°
HEIGHT – 281 mm
WIDTH – 279 mm
THICKNESS – 15 mm
WEIGHT – 1.30 kg
SWL – 6200 kg (vertical)
WEBBING – 40 mm



MOD. FB32.160JA

ASYMMETRIC SLIDER WITH JOINT

For inclined battens of top-square sails.

LENGTH – 160 mm
WEIGHT – 0.90 kg
SWL – 2500 kg

THREADED PIN – M14-16
Smaller thread sizes available on request.

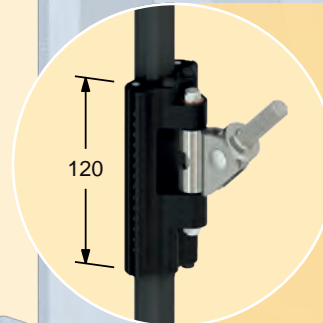

MOD. FB32.100S

SIMPLE SLIDER
LENGTH – 100 mm
WEIGHT – 0.43 kg
SWL – 1600 kg
WEBBING – 25 mm

MOD. FB32.160J

SLIDER WITH JOINT
LENGTH – 160 mm
WEIGHT – 0.90 kg
SWL – 2500 kg
THREADED PIN – M14-16

MOD. 609.326

SBR RECEPTACLE
on page 179



LEASH **NEW**

FB32 SYSTEM



TRACK 32x20
Page 177

FOR **50-100 FT** BOATS

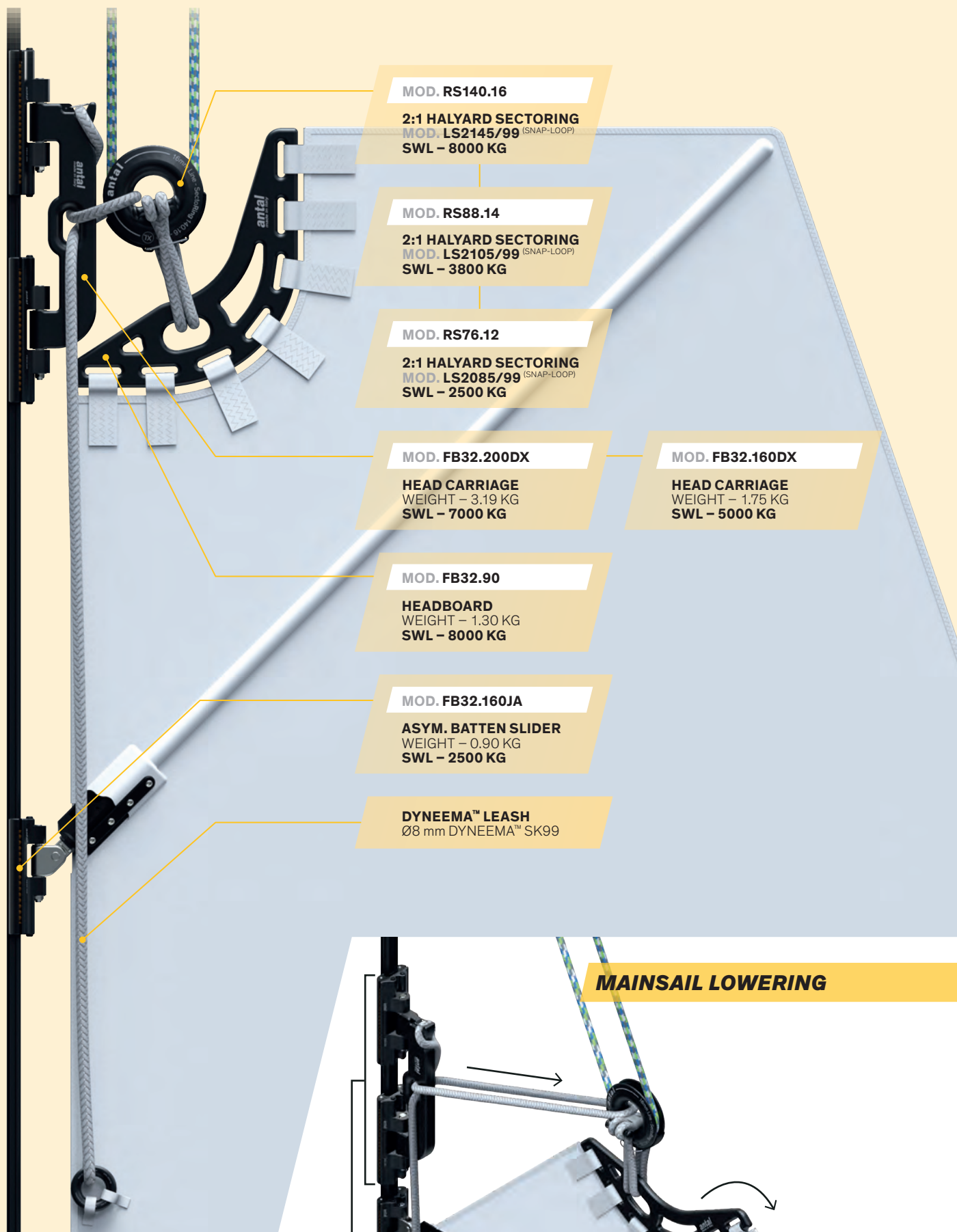

MOD. RS140.16

2:1 HALYARD SECTORING
MOD. LS2145/99 (SNAP-LOOP)
SWL – 8000 KG

MOD. RS88.14

2:1 HALYARD SECTORING
MOD. LS2105/99 (SNAP-LOOP)
SWL – 3800 KG

MOD. RS76.12

2:1 HALYARD SECTORING
MOD. LS2085/99 (SNAP-LOOP)
SWL – 2500 KG

MOD. FB32.200DX

HEAD CARRIAGE
WEIGHT – 3.19 KG
SWL – 7000 KG

MOD. FB32.160DX

HEAD CARRIAGE
WEIGHT – 1.75 KG
SWL – 5000 KG

MOD. FB32.90

HEADBOARD
WEIGHT – 1.30 KG
SWL – 8000 KG

MOD. FB32.160JA

ASYM. BATTEN SLIDER
WEIGHT – 0.90 KG
SWL – 2500 KG

DYNEEMA™ LEASH

Ø8 mm DYNEEMA™ SK99

MAINSAIL LOWERING

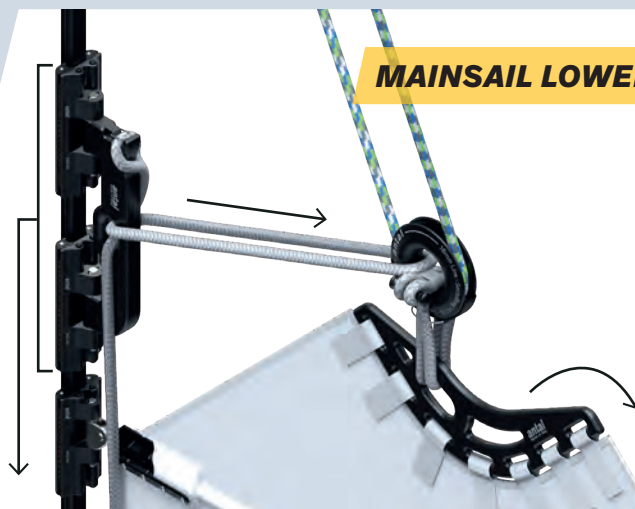

FB42.200 **NEW**

FB42 TRACK, 200^{MM} SLIDERS



TRACK 42x26

FOR BOATS OVER **100 FT**



A CUSTOM-DESIGNED BATTENED MAINSAIL SYSTEM IS AVAILABLE ON REQUEST FOR BOATS OVER **100 FT**.



HS22

TRACK

FOR BOATS UP TO 40 FT AND
RACING BOATS FROM 35 TO 55 FT

HS22 track is made for systems:

- **MOD. HS22.40, MOD. HS22.40R**
on page 159
- **MOD. HS22.50R**
on page 160
- **MOD. HS22.60R**
on page 161

MOD. HS22.13 END FITTING

Made in plastic, should be attached to the mast with 2x5 mm screws.

MOD. HS22.12 JOINT

In order to ensure proper alignment the sections of the track can be joined together with a Nylon fitting; track joint is supplied with 2 screws.

SLUGS AND SCREWS

7 standard models for round or flat grooves are available, custom slugs for special grooves are made on request.

Consider 17 slugs for 2 m of track with 120 mm hole spacing or 1 m of track with 60 mm hole spacing.

Screws (**included**) must be fixed using Loctite 222 or similar.

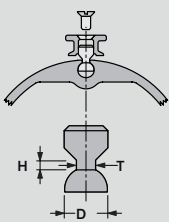

SLUGS → ROUND GROOVE

MODEL	T mm	D mm	H mm
Ø5x10 mm screws			
HS22R04	3.9	8.7	2.0
HS22R05	4.7	9.5	2.0
HS22R06	5.7	10.5	2.0

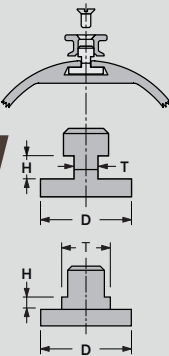

SLUGS → FLAT GROOVE

MODEL	T mm	D mm	H mm
HS22F05	4.7	18.0	4.6
HS22F06	5.7	18.0	4.6
HS22F08	7.8	20.0	4.6
HS22F10	9.8	20.0	2.0
Ø5x10 mm screws			
HS22F12	11.8	22.0	3.0
HS22F14	13.6	24.0	3.0

MOD. HS22.15 INSTALLATION TOOL

It is necessary to position the slugs with the mast in vertical position (with track **MOD. HS22.221** and **MOD. HS22.222**).

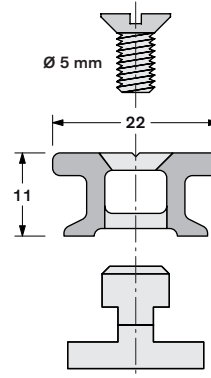

TRACK

The track is an aluminium extrusion hard black anodized and teflon coated.

WEIGHT – 0.34 kg/m

MODEL	HOLE SPACING mm	LENGTH m
DIRECT MOUNTING		
HS22.311	120.5	3
HS22.312	60.25	
SLUG MOUNTING, VERTICAL MAST		
HS22.221	120.5	2
HS22.222	60.25	
SLUG MOUNTING, HORIZONTAL MAST		
HS22.321	120.5	3
HS22.322	60.25	

Direct mounting requires drilling and tapping holes in the mast, slug mounting does not. 120 mm hole spacing for 40-50 ft boats, 60 mm hole spacing for 50-60 ft boats.

MOD. HS22.16 GATE

A stretch of mobile track is placed above the lowered mainsails. When the gate is removed, the head carriage and top batten slider of a square top mainsails can be extracted.

MOD. HS22.11 LOADER

It allows the cars to be loaded and unloaded easily; the loader includes a stop-pin which provides 2 positions: open and closed.

FIXING – 2xØ5 mm screws

L – 175 mm

WEIGHT – 0.10 kg

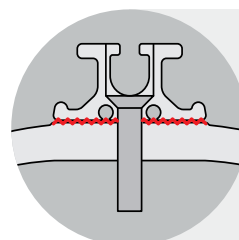

The **HS22** is also available in the glued version, which is particularly suitable for carbon masts.

Tracks and accessories on the following pages.

HS22

TRACK FOR CARBON MASTS

FOR RACING BOATS
FROM 40 TO 60 FT

GLUED TRACKS

Wide base profiles for secure strong gluing, particularly suitable for carbon masts. Use for gluing "SP System Spabond 445" or similar. These tracks always have bolt-rope groove.

MOD. HS22.03 END FITTING

Made in plastic, should be attached to the mast with 2x5 mm screws.

MOD. HS22.05 SIDE PLATES

Fixing can be improved, on most loaded zones (mast head and reefing positions), with 2 aluminium side plates screwed to the mast.

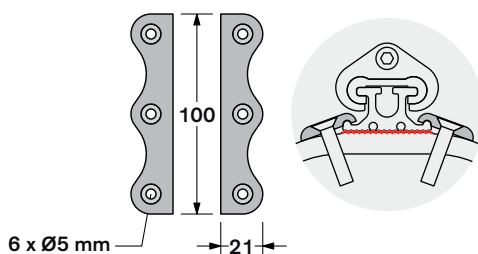

MOD. HS22.330 TRACK FOR CARBON FIBER MAST

Aluminium profile hard black anodized and teflon coated. It's available in 3 m sections.

LENGTH - 3 m
WEIGHT - 0.56 kg/m

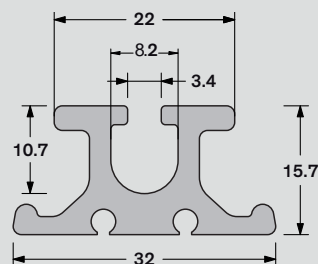

FIXING

The track will be glued to the mast (SP System, Spabond 445). For an easier gluing each track is fixed with 4 positioning screws.

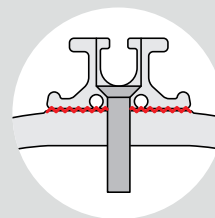

MOD. HS22.16 GATE

A stretch of mobile track is placed above the lowered mainsails. When the gate is removed, the head carriage and top batten slider of a square top mainsails can be extracted.

MOD. HS.02 TRACK JOINT

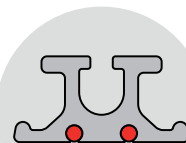

Connection of different sections will be done with 2 S.Steel pins.

MOD. HS22.01 LOADER

It allows the cars to be loaded and unloaded easily; the loader includes a stop-pin which provides 2 positions: open and closed.

L - 500 mm
WEIGHT - 0.30 kg



HS24/FB24

TRACK

FOR 50, 60, 70 FT BOATS

HS24/FB24 tracks are made for HS guide systems:

- **MOD. HS24.50**
page 162
 - **MOD. HS24.60**
page 163
 - **MOD. HS24.70**
page 164
- Fibreball systems:
- **MOD. FB24.60**
page 168
 - **MOD. FB24.90**
page 169
 - **MOD. FB24.120**
page 170

MOD. HS24.13 END FITTING

Made in plastic, should be attached to the mast with 2x6 mm screws.

SLUGS AND SCREWS

8 standard models for round or flat grooves are available; custom slugs special grooves are made on request.

Consider 20 slugs for 2 m of track with 100 mm holes spacing or 1 m of track with 50 mm holes spacing.

Screws (**included**) must be fixed with Loctite 222 or similar.

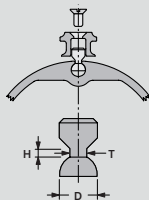

SLUGS → ROUND GROOVE			
MODEL	T mm	D mm	H mm
Ø6x12 mm screws			
HS24R04	3.7	10.0	2.5
HS24R06	5.7	11.6	2.5

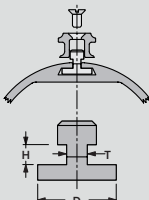

SLUGS → FLAT GROOVE			
MODEL	T mm	D mm	H mm
HS24F05	4.8	19.0	4.6
HS24F06	5.8	19.0	5.7
HS24F08	7.8	19.0	6.7
HS24F10	9.6	22.0	6.7
↑ Ø6x12 mm screws ↑			
↓ Ø6x14 mm screws ↓			
HS24F12	11.6	22.0	3.0
HS24F14	13.6	24.0	3.0

MOD. HS24.15 INSTALLATION TOOL

It is necessary to position the slugs with the mast in vertical position; with tracks MOD. HS24.221 and MOD. HS24.222.

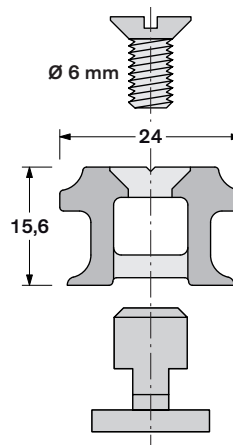
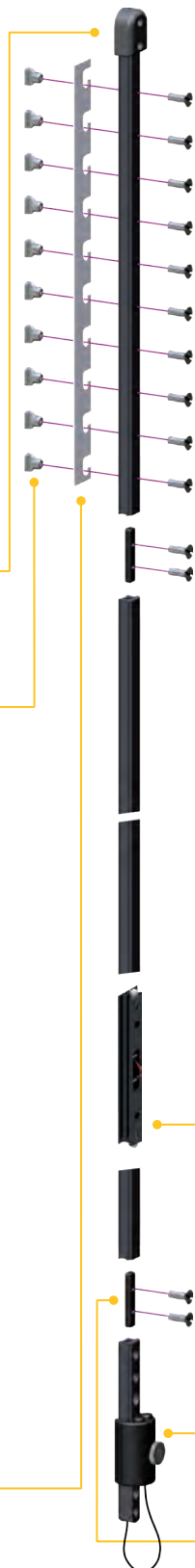

TRACK

Aluminium profile hard black anodized and teflon coated.
WEIGHT – 0.55 kg/m

MODEL	HOLE SPACING mm	LENGTH m
DIRECT MOUNTING		
HS24.311	100	3
HS24.312	50	
SLUG MOUNTING, VERTICAL MAST		
HS24.221	100	2
HS24.222	50	
SLUG MOUNTING, HORIZONTAL MAST		
HS24.321	100	3
HS24.322	50	

Direct mounting requires drilling and tapping holes in the mast; track will be screwed to the mast; lengths of 3 m available.

50-60 ft BOATS – HOLE SPACING 100 mm
60-70 ft BOATS – HOLE SPACING 50 mm

MOD. HS24.16 GATE

A stretch of mobile track is placed above the lowered mainsails. When the gate is removed, the head carriage and top batten slider of a square top mainsails can be extracted.

MOD. HS24.11 LOADER

It allows the cars to be loaded and unloaded easily; the loader includes a stop-pin which provides two positions: opened and closed.

FIXING – 2xØ6 mm screws
L – 200 mm
WEIGHT – 0.19 kg

MOD. HS24.12 JOINT

In order to ensure proper alignment the sections of the track can be jointed together with a Nylon fitting; track joint is supplied with 2 screws.

HS24/FB24

TRACK FOR CARBON MASTS

FOR RACING BOATS
FROM 50 TO 70 FT

We've just developed a new **HS24 track** which is supposed to be glued to the mast.

From the great success of our HS22 Carbon Track (page 173) we noticed that the glue-mounted tracks are more and more popular, both on carbon and aluminium masts.

MOD. HS24.03 END FITTING

Made in aluminium; should be attached to the mast with 2x6 mm screws.

MOD. HS24.05 SIDE PLATES

Fixing can be improved, on most loaded zones (mast head and reefing positions), with 2 aluminium side plates screwed to the mast.

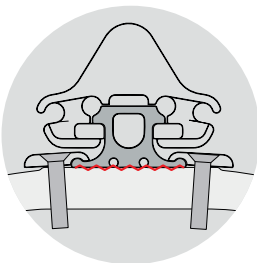
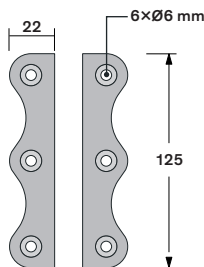

MOD. HS24.06 GATE

A stretch of mobile track is placed above the lowered mainsails. When the gate is removed, the head carriage and top batten slider of a square top mainsails can be extracted.

L – 264 mm



The HS24 carbon track is also available in the bolt-rope version on request.

MOD. HS24.350 TRACK FOR CARBON FIBER MAST

Aluminium profile hard black anodized and teflon coated. Available in 3m sections.

LENGTH – 3 m
WEIGHT – 0.817 kg/m

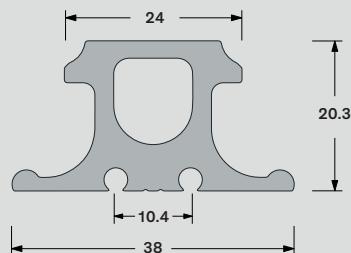

MOD. HS24.02 TRACK JOINT

Connection of different sections will be done with 2 S.Steel pins.

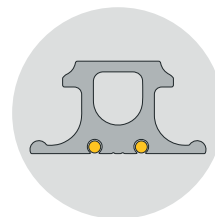

FIXING

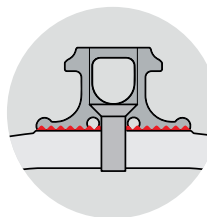

The track will be glued to the mast (SP SYSTEM, SP-ABOND 445). For an easier gluing each track is fixed with 4 positioning screws.

MOD. HS24.04 LOADER

It allows the cars to be loaded and unloaded easily; the loader includes a stop-pin which provides 2 positions: open and closed.

L – 200 mm
WEIGHT – 0.25 kg

HS30

TRACK

FOR 80, 90, 100 FT BOATS

MOD. HS30.313 TRACK

The extremely light (500 gr/m) hard black anodized and teflon coated aluminium profile is very small (only 13x30 mm). It is fixed directly to the mast with 6 mm screws every 50 or 25 mm (without inserts) and is available in 3 m sections.

WEIGHT – 0.50 kg/m

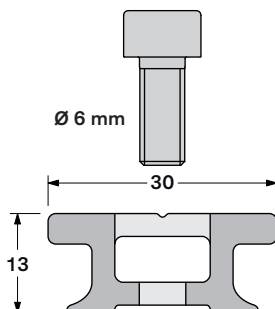

MOD. HS30.313R TRACK RACE

As above with lightening holes.

WEIGHT – 0.46 kg/m

HS30 BOLT-ROPE TRACK FOR CARBON FIBER MAST

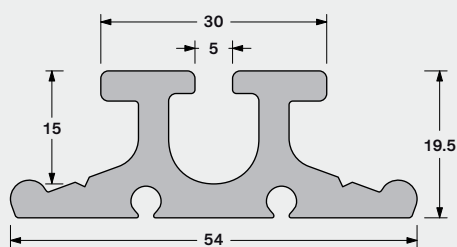

MOD. HS30.330 TRACK

Aluminium profile hard black anodized and teflon coated. It's available in 3 m sections.

WEIGHT – 1.10 kg/m

FIXING

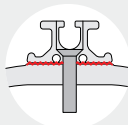

The track will be glued to the mast (SP SYSTEM, SPABOND 445). For an easier gluing each track is fixed with 4 positioning screws.



HS30 track is made for HS guide systems:

- **MOD. HS30.90**
page 163
- **MOD. HS30.130**
page 164

MOD. HS30.13 END FITTING

Made in aluminium, should be attached to the mast with the 2x6 mm screws.

MOD. HS30.12 JOINT

In order to ensure proper alignment the sections of the track can be joined together with an aluminium fitting. Screws not included.

MOD. HS30.11 LOADER

It allows the cars to be loaded and unloaded easily; the loader includes a stop-pin which provides two positions: opened and closed.

FIXING – 2xØ6 mm screws
L – 210 mm
WEIGHT – 0.20 kg

MOD. HS30.03 END FITTING

Made in aluminium, should be attached to the mast with the 3x6 mm screws.

MOD. HS30.05 SIDE PLATES

Fixing can be improved, on most loaded zones (mast head and reefing positions), with 2 alu side plates screwed to the mast.

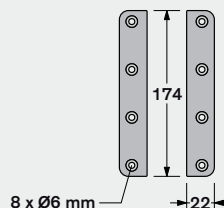

MOD. HS.02 JOINT

Connection of different sections will be done with 2 S.Steel pins.



MOD. HS30.01 LOADER

It allows the cars to be easily loaded and unloaded.

L – 990 mm
WEIGHT – 1.20 kg

FB32.160

TRACK

FOR BOATS FROM 80 TO 100 FT

MOD. FB32.13 END FITTING

Made in plastic, should be attached to the mast with 2xØ8 mm screws.

WEIGHT – 87 gr (screws included)

MOD. FB32.12 JOINT

In order to ensure proper alignment the section of the track will be joined together with this Nylon fitting: it is supplied with 2 screws.

MOD. FB32.15 INSTALLATION TOOL

It is necessary to position the slugs with the mast in vertical position; with tracks MOD. FB29.221.

SLUGS

Available on request, for Ø8 mm screws.

FB32.160 track is made for Fibreball system:

- **MOD. FB32.160**
page 169

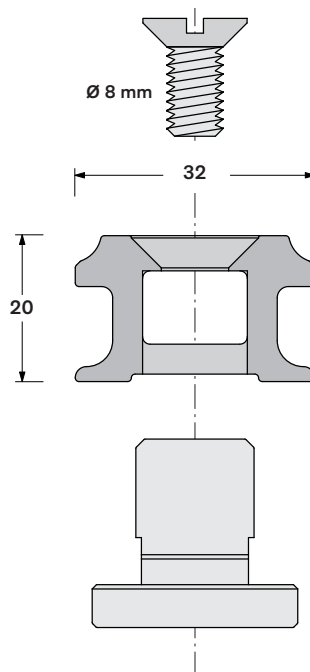

TRACK

Aluminium profile hard black anodized and teflon coated.
WEIGHT – 0.92 kg/m

MODEL	HOLE SPACING mm	LENGTH m
DIRECT MOUNTING		
FB32.311	100	3
SLUG MOUNTING		
FB32.321	100	3

Direct mounting requires drilling and tapping holes in the mast, slug mounting does not.

MOD. FB32.16 GATE

A stretch of mobile track is placed above the lowered mainsails. When the gate is removed, the head carriage and top batten slider of a square top mainsails can be extracted.

L – 371 mm

MOD. FB32.11 LOADER

It allows the cars to be easily loaded and unloaded.

FIXING – 2xØ8 mm screws.

L – 300 mm

WEIGHT – 376 gr



SPECIAL PRODUCTS

FAST-RELEASE HR PUSH-PINS

Are available for the main headboard connection to the head carriage. Made in HR S.Steel to offer the highest loads, with a security-line and an easy grip for a quick coupling and release.

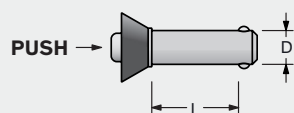
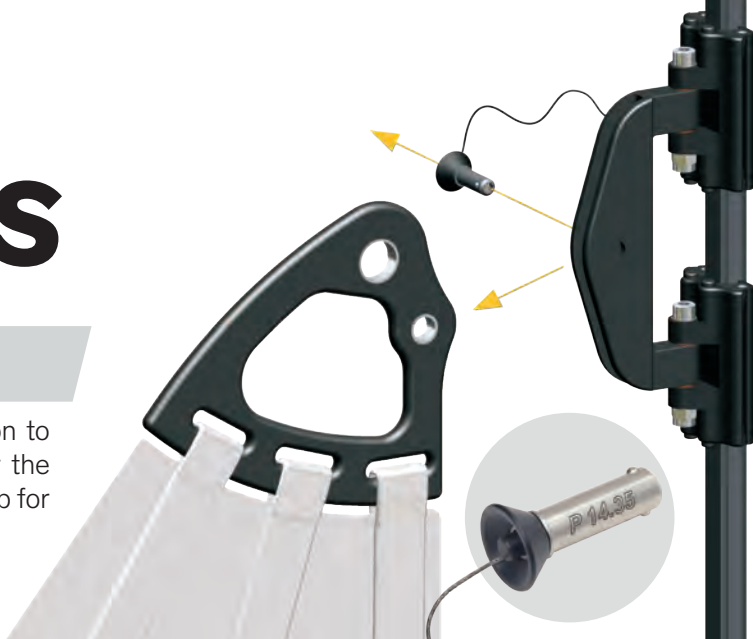

MODEL	D mm	L mm	SWL kg	CARRIAGE CODE MODEL
P10.20	10	20	1600	HS22.50DR - HS24.50D - HS24.60D - FB24.60D
P14.25	14	25	5000	HS22.60TR - HS22.70TR - HS24.60T - HS24.70T FB24.90D - HS24.70Q - FB24.120D
P14.35	14	35	5000	HS30.70Q - HS30.90Q - FB32.160D
P14.42	14	42	5000	HS24.90DY - HS30.90DY NEW

FEEDER CARRIAGE



Mounted on the bolt-rope tracks to bend the mainsail inside the bolt-rope-groove. It can be easily removed to fit the mainsail with sliders.

MOD. HS22.09 for loader **MOD. HS22.01** of **HS22.330** track (page 173)

MOD. HS30.09 for loader **MOD. HS30.01** of **HS30.330** track (page 176)

GATE



A stretch of mobile track is placed above the lowered mainsails. When the gate is removed, the head carriage and top batten slider of a square-top mainsails can be extracted to make it easier to "tie" the mainsail to the boom.

MOD. HS22.16 L – 204 mm → for **HS22** track (page 172)

MOD. HS22.06 L – 204 mm → for **HS22.330** track (page 173)

MOD. HS24.16 L – 264 mm → for **HS24** track (page 174-175)

MOD. HS24.06 L – 264 mm → for **HS24.350** track (page 175)

MOD. HS30.16 L – 264 mm → for **HS30** track (page 176)

MOD. FB32.16 L – 264 mm → for **HS30** track (page 177)





BATTEN RECEPTACLES

SBR – SYMMETRIC BATTEN RECEPTACLE ROUND BATTENS

The SBR is different from standard batten receptacles in that it fits inside the batten pocket, making it invisible on the outside except for the small fastening plate - thereby almost completely eliminating chafe on the mast and rigging. Moreover the batten will be not on one side, but perfectly in the middle.



Each SBR includes:

- 1 the main body.
- 2 side plates to fix the receptacle to the sail.
- 3 trimming screw for batten compression.
- 4 the cap with a threaded hole to screw the receptacle in the toggle of the batten slider.

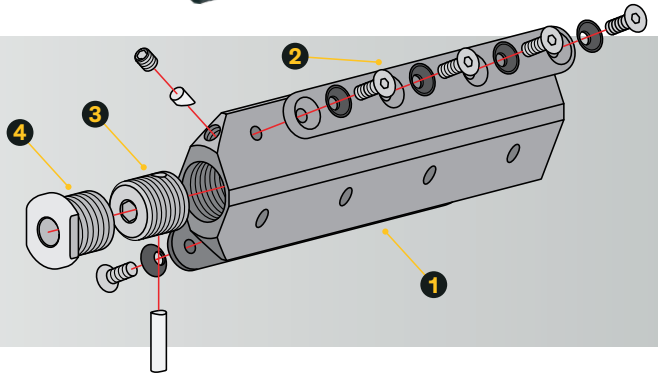

RESIN SBR, FOR ROUND AND FLAT BATTENS

Completely made of high-strength, 50% glass fiber resin, max UV resistance, with self-tapping screws to offer a very fast and easy mounting. For boats up to 40 ft.



MOD. 609.320

For round batten.
For 10 mm threaded toggle.
WEIGHT – 0.08 kg
FIXING SCREWS – 6

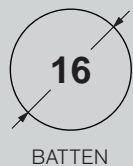
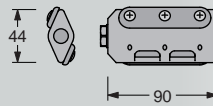

MOD. 609.321

For round batten.
For 10 mm threaded toggle.
WEIGHT – 0.13 kg
FIXING SCREWS – 8

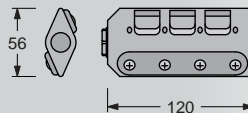

MOD. 609.327

For round batten.
For 10-12 mm threaded toggle.
WEIGHT – 0.25 kg
FIXING SCREWS – 8

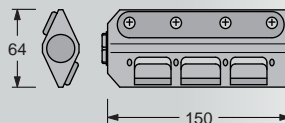

These resin made receptacles are very light, for this reason they can be used also on the leech side.

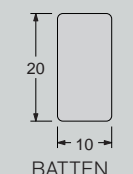

MOD. 609.322

For flat batten.
For 10 mm threaded toggle.
WEIGHT – 0.10 kg
FIXING SCREWS – 8

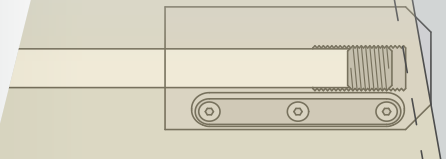
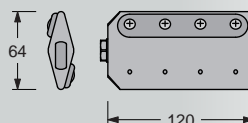

ALUMINIUM SBR FOR ROUND BATTENS

Main body and side plates are aluminium made with 6 mm AISI316 screws, the S.Steel A316 cap for the batten car toggle connection is available with different threads.

These SBR receptacles are suitable for boats up to 100 ft.



MOD. 609.323

For round batten.
For 10-12 mm threaded toggle.
WEIGHT – 0.45 kg
FIXING SCREWS – 6

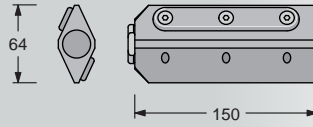

MOD. 609.324

For round batten.
For 10-12 mm threaded toggle.
WEIGHT – 0.54 kg
FIXING SCREWS – 8

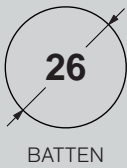
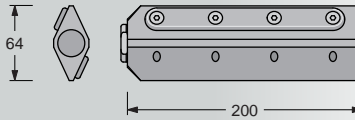

MOD. 609.325

For round batten.
For 12-14 mm threaded toggle.
WEIGHT – 0.62 kg
FIXING SCREWS – 8

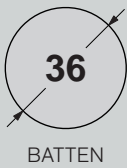
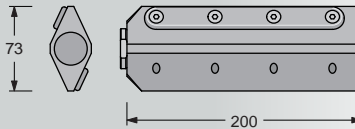

MOD. 609.326

For round batten.
For 14-16 mm threaded toggle.
WEIGHT – 1.05 kg
FIXING SCREWS – 14

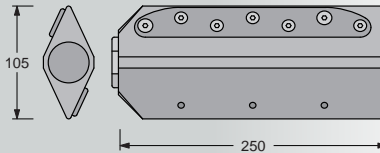

On the same receptacle a number of threads for the connection with the batten slider toggle are available.

So it will be necessary to specify not only the receptacle model (from **MOD. 609.323** to **MOD. 610.326**) but also the thread size: 10, 12, 14 or 16 mm.

Ice Yachts 54 – Ph. C. Borlenghi



RESIN STANDARD RECEPTACLES FOR ROUND AND FLAT BATTENS

Made of high-strength resin with max UV resistance.
FIXING – 4 screws + 4 self-locking nuts
Made for **Antal system HS22.40**.

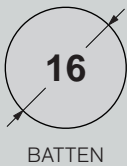

MOD. 610.341

For round batten.
For 10 mm threaded toggle.
WEIGHT – 0.06 kg
FIXING SCREWS – 4

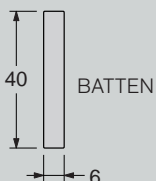
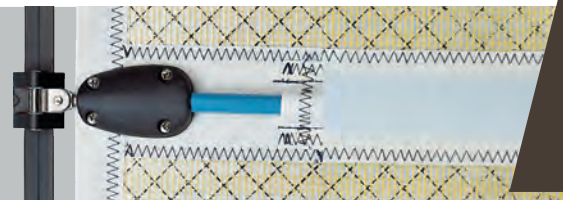
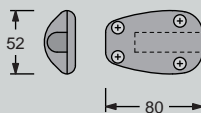

MOD. 610.340

For flat batten.
For 10 mm threaded toggle.
WEIGHT – 0.06 kg
FIXING SCREWS – 4

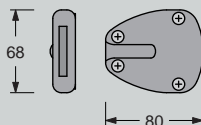

HOOK CARRIAGES



TRACK 24x16
Page 174-175

FOR 60 FT BOATS

HOOK CARRIAGE

This head carriage has been designed for **Antal track HS24** (page 174). It is fitted with a hook that automatically catches specific hook stops on the mast track to unload the halyard.

Two lines from the carriage run down the sail:

- 1 to disengage the hook so that the carriage is free to descend;
- 2 to load the hook, which attaches to the first hook-stop.

These two lines are connected so when one is pulled the other is automatically released.



MOD. HS24.210

→ **HOOK CARRIAGE FOR HS24 TRACK**

WEIGHT – 1,06 kg
LENGTH – 210 mm
SWL – 2400 kg

The carriage is fitted with a swivelling bracket on which it is possible to mount any headboard from the HS24.60 series (page 161) or the **MOD. HS24.61**, specifically designed for this carriage. The halyard is fixed to the headboard.

MOD. HS24.61

→ **SPECIAL HEADBOARD FOR HOOK CARRIAGE**

SIZES – 120x130 mm
WEIGHT – 0,25 kg
SWL – 2400 kg

MOD. HS24.17

→ **HOOK STOP FOR HS24 TRACK** (page 172)

Fitted on a 340 mm long track that is screwed to the mast with 8 x Ø6 mm screws.

MOD. HS24.18

→ **AUTOMATIC HOOK-STOP FOR HS24 TRACK** (page 172)

Similar to the previous model, it has been designed for the mast head. By simply pulling the halyard for a few centimeters, the carriage moves up, the hook is automatically disengaged and the carriage is free to descend. Therefore, even in the event of breakage of the line that frees the hook, the sail can be lowered.

To avoid too many junctions in the track, Antal offers custom tracks with hook-stops that are already fitted at the required points based on the design of the mainsail and reef locations: one hook-stop at the top and two or three for the reefs along the track.

Hook Stop for HS24 Carbon Track (page 175) is also available (**MOD. HS24.07** and **MOD. HS24.08**).

HOOK CARRIAGE

MOD. HS24.210R

→ **HOOK CARRIAGE FOR HS24 TRACK**

The carriage is fitted with a swiveling bracket suitable for tying directly on the sail head.

WEIGHT – 1,06 kg
LENGTH – 210 mm
SWL – 2400 kg





This head carriage has been designed for **Antal track HS22** (page 172). It is fitted with a hook that automatically catches specific hook stops on the mast track to unload the halyard.

Two lines from the carriage run down the sail:

- 1 to disengage the hook so that the carriage is free to descend;
- 2 to load the hook, which attaches to the first hook-stop.

MOD. HS22.165 → **MINI HOOK CARRIAGE FOR HS22 TRACK** (page 172)
WEIGHT – 0.42 kg
LENGTH – 160 mm
SWL – 1400 kg

MOD. HS22.17 → **HOOK-STOP FOR HS22 TRACK** (page 172)
Fitted on a 340 mm long track that is screwed to the mast with 7×Ø5 mm screws.

MOD. HS22.27 → **HOOK-STOP FOR HS22 CARBON TRACK** (page 173)
Fitted on a 340 mm long track that is screwed to the mast with 4×Ø5 mm screws.

2:1 MINI HEADBOARD SLIDER FOR HS22 TRACK



This model, designed for class 40ft, is fitted with a 40 mm high load sheave for a 2:1 halyard; the main-sail head will be simply tied to the slider with a line.

WEIGHT – 0.45 kg
LENGTH – 185 mm
SWL – 2000 kg

MOD. HS22.185 → **FOR HS22 TRACK** (on page 172)

DOUBLE HEAD SLIDER FOR RING CONNECTION



Two 90 mm long sliders with a bracket will be connected to the ring on the head of the mainsail.

WEIGHT – 0.87 kg
LENGTH – 240 mm
SWL – 3200 kg

MOD. HS24.90DY → **FOR HS24 TRACK** (on page 174)

MOD. HS30.90DY → **FOR HS30 TRACK** (on page 176)

DOUBLE HEAD SLIDER WITH SOFT-LINK



Two 90 mm long sliders with a bracket will be tied to the ring on the head of the mainsail.

WEIGHT – 0.65 kg
LENGTH – 240 mm
SWL – 3200 kg

MOD. HS24.90DX → **FOR HS24 TRACK** (on page 172)

MOD. HS30.90DX → **FOR HS30 TRACK** (on page 176)





SOFT LINKS



DS series 187



Dyneema™ pad-eyes 188



T-Lock 189



Deck rings 190



Low friction rings 192



Solid rings 193



Mast fairleads 194



Rings and loops 196



Hook 196



SectoRing 197



Snap-loops 198



DS NEW

SERIES

NEW DECK SHACKLE SPECIALLY CONCEIVED FOR VERTICAL LOADS AND TEXTILES

The new **MOD. DS06**, **DS08** and **DS10** are folding aluminum deck shackles, suitable for soft lashing and splicing as a Dyneema™ loop.

Compared to the Antal Dyneema™ pad-eye, DS series are particularly suitable for vertical loads (i.e. furlers tack in single or 2:1, textile forestay, runners, etc.).

The deck shackles must be positioned so that the load direction is in the indicated green areas where it offers the maximum resistance.



MODEL	WEIGHT g	L mm	A mm	SCREWS N x Ø mm	SWL kg
DS06	77	51	50	3 x Ø6	1500
DS08	176	63	68	3 x Ø8	3000
DS10	280	79	85	3 x Ø10	4500

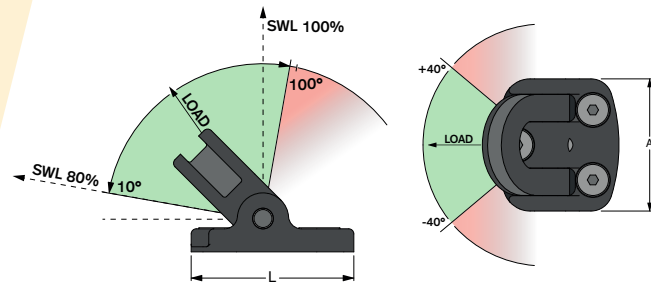

SOFT LINKS

The use of **Dyneema™** lines, characterized by high stiffness and strength and by excellent smoothness, resulted in the development of new equipment that exalts these properties.

First the fastenings called soft-links: Dyneema™ loops and snap-loops that replace shackles, snap-shackles and other metal connections.

Then the rings, now produced in different versions and many sizes that exploit the excellent sliding of Dyneema™ lines, replace sheaves and blocks for more and more manoeuvres.

The advantages of this new equipment are: high resistance, increased lightness, a reduction in size and significant cost savings.

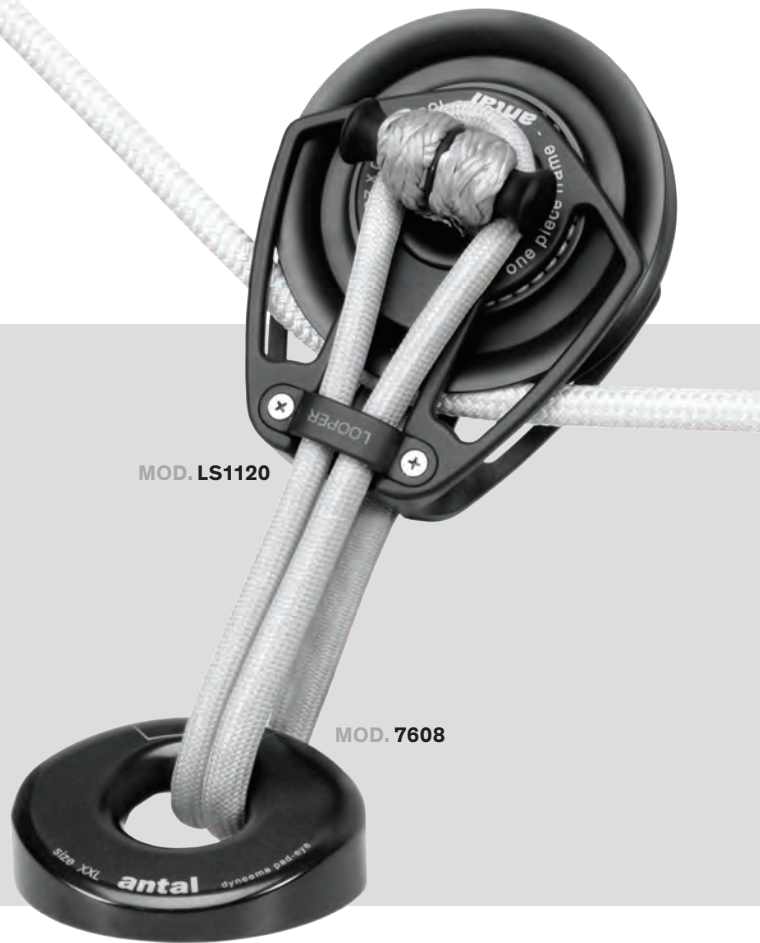

DYNEEMA™ PAD-EYES

Special extremely light, "low profile" pad-eye, designed for Dyneema™ loop in hard black anodized aluminium.

The Dyneema™ pad-eye is available in **two versions**: with studs from the ottom and a perfectly smooth upper surface; with screws from above.

Studs or screws, washers and nuts **included**.

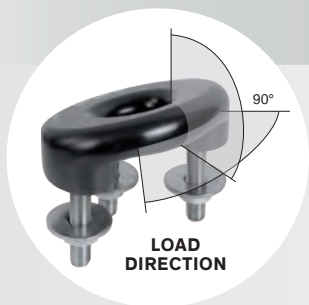

Studs from the bottom



Screws from above

WITH SCREWS



WITH STUDS



THE STUDY OF THE PULL DIRECTION

DPE offers great performance on a wide angle. DPE's profile is so low and smooth that it is walkable. This is because we designed this pad-eye starting from its pull direction, and not for a simple coupling.

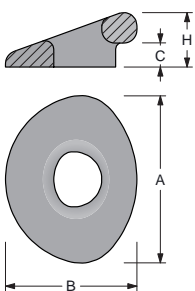

NEW

MODEL	MODEL	SOFT LINK mm	A mm	B mm	H mm	C mm	SWL kg	WEIGHT* g	SCREWS N x Ø mm
7505	7605	5	43	34	16	7	600	22	2 x Ø6
7506	7606	6	58	45	21	10	1300	50	3 x Ø6
7508	7608	8	77	60	27	12	2200	90	3 x Ø8
7510	7610	10	93	74	34	16	3500	180	3 x Ø10
7512	7612	12	112	89	41	19	5000	370	3 x Ø12
7514	7614	14	123	97	46	21	6800	520	4 x Ø12
7516	7616	16	144	115	56	26	9000	870	4 x Ø14

* Without screws-nuts.

Do not use Antal Dyneema™ Pad-eyes for boat lifting.

T-LOCK

FLUSH MOUNTED

T-LOCK FOR SWIVELLING AND REMOVABLE DECK LOOPS

T-Lock is a flush-mounted deck base to which a loop can be connected. A special toggle, which automatically locks-in, fits into the base.

It cannot be removed under load, but can easily be removed without a load on it. The toggle can be locked-in permanently which makes it not-removable. The toggle is swivelling, it can take a load in any direction.



MOD. TL22.33

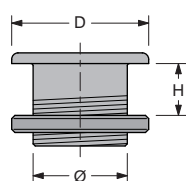

T-LOCK		When the toggle is used as a dog-bone it will adapt to any Dyneema™ loop, such as a simple loop, low friction ring with loop and a snatch block with loop. Two models are available, sizes and characteristics are shown in the table.				TOGGLE	LOOP AND TOGGLE	RING
MODEL	D mm	MAX DECK H mm	DECK HOLE Ø mm	SWL kg	WEIGHT g	MODEL	MODEL	MODEL
TL22.33	64	33	44	2200	170	TT22.33	TD22.33	R20.14
TL28.41	74	44	54	3500	300	TT28.41	TD28.41	R28.20

Do not use Antal T-Lock for boat lifting.



SIMPLE TOGGLE: this is an aluminium dog-bone suitable for splicing your own loop, models in the above table are available on request.



LOOP AND TOGGLE: this is a multi-ring Dyneema™ loop with a cover linked to the toggle, it is always included in the T-Lock.



LOW FRICTION RING: a ring can be inserted in the Dyneema™ loop, models in the above table are available on request.



← T-Lock basis + Looper blocks

BLOCKS: Looper blocks (page 80) can be lashed to the toggle and easily locked-in the T-Lock base. This feature is optional.

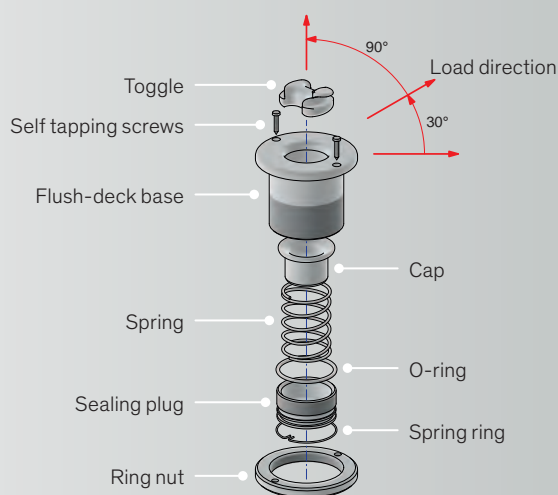

There are two positions for the sealing plug:

- 1. LOW POSITION (unscrewed):** in this position it is possible to fit the toggle into the base or to take it off (only if not under load).
- 2. HIGH POSITION (screwed):** in this position the toggle is permanently locked into the base and it is not possible to take it off.

For load directions with angles of less than 30°, the sealing plug must be completely tightened so as to lock the slug and avoid accidental unhooking.

DECK RINGS

ALUMINIUM DECK RINGS

Two sizes, highly polished and hard black anodized aluminium deck ring. Screws **included**.

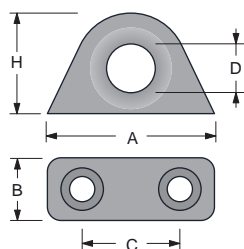

MODEL	A mm	B mm	C mm	D mm	H mm	SWL kg	WEIGHT* g	SCREWS N x Ø mm
R14.14	48	18	28	14	29	800	25	2 x Ø6
R20.20	59	19	38	20	39	800	45	2 x Ø6

* Without screws-nuts.

MOD. R14.14



MOD. R20.20

S.STEEL DECK RINGS

Two sizes, highly polished S.Steel deck ring. Screws **included**.

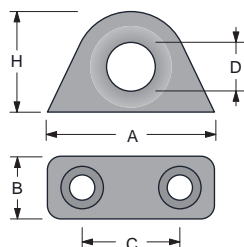

MODEL	A mm	B mm	C mm	D mm	H mm	SWL kg	WEIGHT* g	SCREWS N x Ø mm
R14.14S	48	18	28	14	29	800	74	2 x Ø6
R20.20S	59	19	38	20	39	1500	120	2 x Ø8

* Without screws-nuts.

MOD. R14.14S



MOD. R20.20S

DOUBLE LINE DECK RINGS

Two sizes, highly polished and hard black anodized aluminium deck ring. The wide hole allows the passage of two lines. Screws **included**.

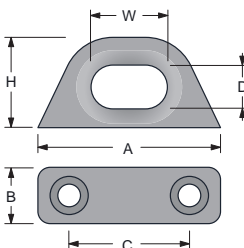

MODEL	A mm	B mm	C mm	H mm	D x W mm	SWL kg	WEIGHT* g	SCREWS N x Ø mm
R12.25	59	18	39	27	12 x 25	800	30	2 x Ø6
R18.36	75	19	54	37	18 x 36	800	56	2 x Ø6

* Without screws-nuts.

MOD. R12.25



MOD. R18.36

MULTI RING ORGANIZER

Antal Low Friction products now include a new organizer: MRO, the Multi-Ring Organizer. A CNC-machined body in hard black anodized aluminium, polished finely to guarantee minimum friction. MROs are easy-to-install, extremely lightweight, resistant and practical organizers.

Just like Ring by Antal, they simplify the mechanics and provide great performance. MROs are available from 2 to 7 lines, and fit lines up to 12 mm.

Screws **not included**.

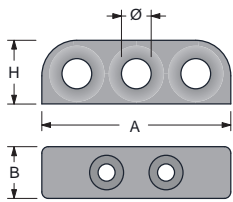

NEW

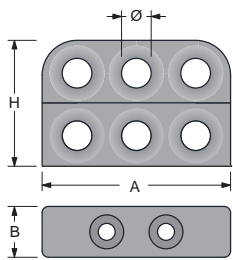

MODEL	HOLES N × Ø mm	A mm	B mm	H mm	SINGLE RING SWL kg	ORGANIZER SWL kg	WEIGHT g	SCREWS N × Ø mm	
R2.14	2 × 14	73	18	29	800	800	50	2 × 6	
R3.14	3 × 14	88	24	29.5		1500	98	2 × 8	
R4.14	4 × 14	116				132			
R5.14	5 × 14	144	165	2250		196	3 × 8		
R6.14	6 × 14	172	3000					230	4 × 8
R7.14	7 × 14	200							
R8.14	8 × 14	229	24	29.5		800	3000	279	4 × 8

MODEL	HOLES N × Ø mm	A mm	B mm	H mm	SINGLE RING SWL kg	ORGANIZER SWL kg	WEIGHT g	SCREWS N × Ø mm		
R2.14D	4 × 14	73	18	59	800	800	177	2 × 6		
R3.14D	6 × 14	88	24			1500	1500	215	2 × 8	
R4.14D	8 × 14	116					290			
R5.14D	10 × 14	144	360			3000	430	3 × 8		
R6.14D	12 × 14	172	490						4 × 8	
R7.14D	14 × 14	200								
R8.14D	16 × 14	229	24			59	800	3000	570	4 × 8

SINGLE RING SWL: the maximum Safe Working Load on the single ring.
ORGANIZER SWL: the maximum Safe Working Load on the organizer.

* Without screws-nuts.

Tutima - Ph. S. Jürgensen

DEFLECTOR

The Antal Deflector is a low friction ring for deck mounting. One piece aluminium made, polished and hard black anodized. Screws **included**.

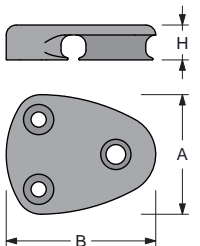

MODEL	MAX LINE Ø mm	A mm	B mm	H mm	SWL kg	WEIGHT g	SCREWS N × Ø mm
D3008	8	48	60	14	1500	49	1 × Ø8 + 2 × Ø6
D3610	10	54	75	17	2300	93	1 × Ø10 + 2 × Ø8

* Without screws-nuts.



LOW FRICTION RINGS

LOW FRICTION RING, THE UNIVERSAL SOLUTION

Six models with holes from 7 to 38 mm, the simplest idea for maximum load and minimum weight.

MODEL	D ₁ mm	D ₂ mm	Ø mm	T mm	WEIGHT g	SWL kg
R07.05	7	18	5	9	3	400
R10.07	10	25	7	12	5	800
R14.10	14	35	10	15	12	1600
R20.14	20	50	14	22	44	3200
R28.20	28	70	20	31	120	6400
R38.28	38	99	28	44	338	10000

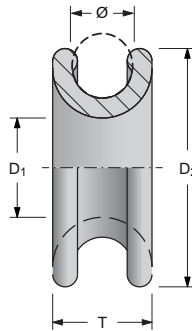

Full scale pics



Turn buckle

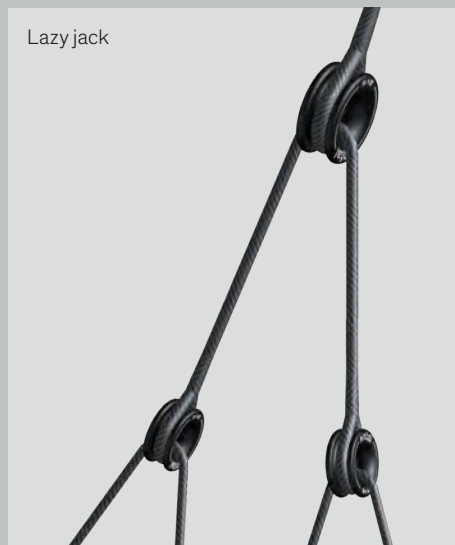

Lazy jack



Furling lead



Barber

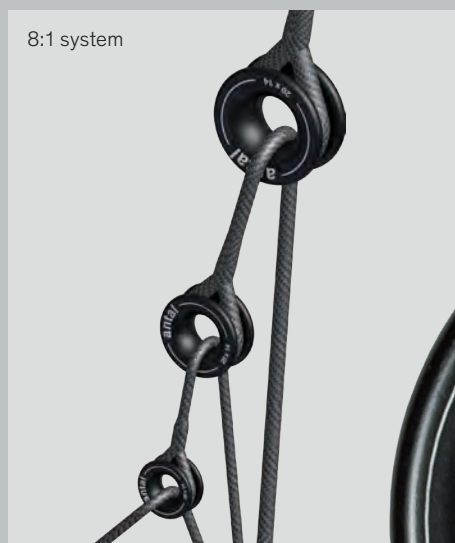

8:1 system

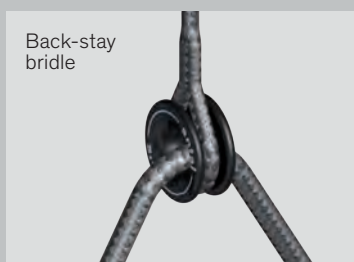

Back-stay bridle

SOLID RINGS

SOLID RINGS

Five models with holes from 22 to 50 mm, the simplest idea for maximum load and minimum weight.

What's good about it?

Compared with Antal Ring, Solid Ring has a thinner body and a wider hole with the same extreme working loads. The outer groove is suitable for a hanging line.

Material and finishing.

Minimum friction, highly polished, hard black anodized aluminium body. Solid ring has been specifically designed for reefing and for 3D setting of the genoa sheet.

MODEL	D ₁ mm	D ₂ mm	T mm	WEIGHT g	SWL kg
R22.44	22	44	14	37	1000
R30.56	30	56	16	62	1800
R34.64	34	64	18	89	2800
R40.76	40	76	22	154	4400
R50.94	50	94	25	266	6500
R50.120	50	119	32	666	10000
R76.160	76	159	46	1641	20000

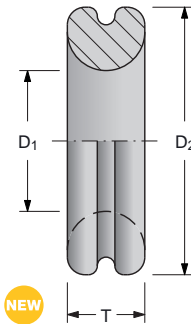

Solid ring has been specifically designed for reefing and for 3D setting of the genoa sheet.



Reefing



3D genoa adjusting



↓ Full scale pics

MOD. R50.94



MOD. R40.76



MOD. R34.64



MOD. R30.56



MOD. R22.44

MAST FAIRLEADS

MAST FAIRLEADS

This **low-friction fairlead** is suitable for mounting on mast, boom and thin wall with no access from behind.

Aluminium made, hard black anodized and highly polished to guarantee minimum friction. 3 sizes with 14, 16 and 18 mm holes for lines up to 10, 12 and 14 mm max.

Just drill a hole of appropriate size (30, 35 or 40 mm for the different models) insert the fairlead into this hole and fix it with two screws (**included**).



MOD. RF14.30

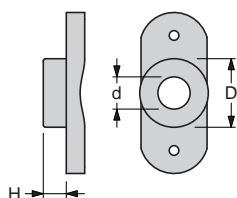

MODEL	d mm	D mm	H mm	WEIGHT g	SCREWS N x Ø mm	MAX LINE Ø mm
RF14.30	14	30	10	39	2 x Ø5	10
RF16.35	16	35	12	62	2 x Ø6	12
RF18.40	18	40	14	90	2 x Ø6	14

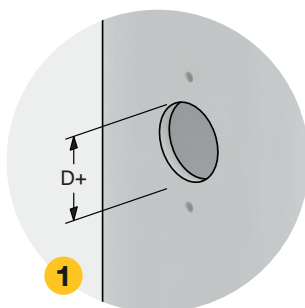

1 Drill a hole with a hole saw.

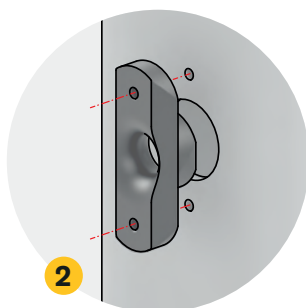

2 Use the Fairlead as a template to mark the position of the two screws and drill the holes.

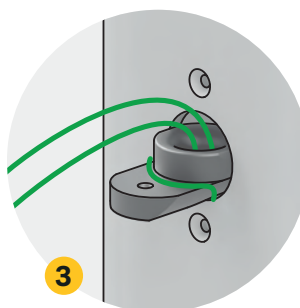

3 Tie the Fairlead with a line, insert it into the hole.

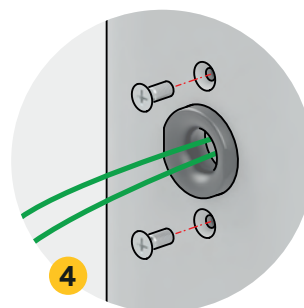

4 Put the Fairlead into place using the line, fit the screws, take off the line and tighten screws.

J-Boats, J111 Fleet



S-DRIVE

S-DRIVE

S-Drive is a low friction fairlead designed for the **mast exit** of halyards with medium-low tension but it is also a solution to drive lines underdeck. S-Drive offers all the advantage of the Low friction rings: light weight and minimum sizes, high load resistance, no maintenance and, not last, low prices. S-Drive is offered in **three sizes** for diameters up to 6, 8 and 10 mm and line tension up to 1800 kg.

On the following table main characteristics are summarized.

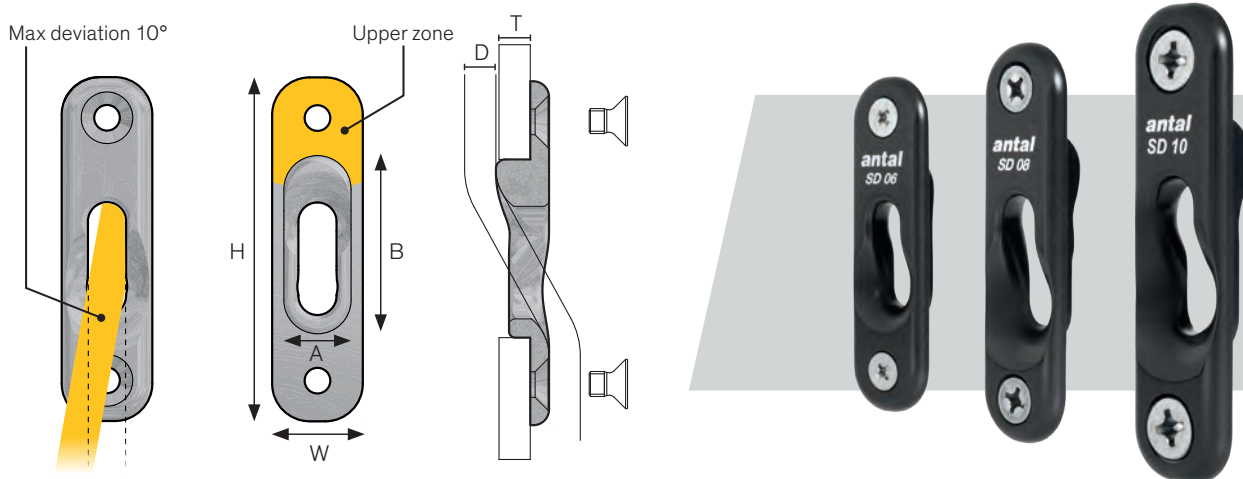

MODEL	MAX LINE Ø mm	MAX LINE TENSION kg	A x B mm	W x H mm	SCREWS*	MAX T mm	TOTAL WEIGHT g
SD06	6	700	15 x 39	22 x 77	2 M5	7	20
SD08	8	1000	17.5 x 50	21.5 x 92	2 M6	9	30
SD10	10	1800	21.5 x 57	29 x 110	2 M8	11	46

Ps. If the wall is very thin – less than the screw diameter – it will be advisable to use some glue (Spabond 445) in the "upper zone".

* Screws are **included**.

Luca Brenta Yachts, B34



RINGS, LOOPS AND HOOK



RINGS AND LOOPS

The Antal low friction rings are available also with a Dyneema™ loop for a fast and easy connection.

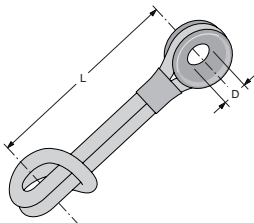

MODEL	D mm	L mm	SWL kg	LOOP Ø mm	RING MODEL
RL3.0	7	60	240	3	R07.05
RL4.0	10	70	400	4	R10.07
RL4.5	10	80	700	4.5	R10.07
RL5.0	14	90	900	5	R14.10
RL6.0	14	110	1500	6	R14.10
RL6.1	20	130	1500	6	R20.14

Breaking Load values have been obtained through tests on new Dyneema™ loops, the Safe Working Load (SWL) is obtained from the Breaking Load with a safety factor = 3 to consider the wear and tear of the Dyneema™ lines.

HOOK

It can be easily "hooked" to a genoa or a spinnaker sheet: the lightest and strongest solution for a line control. Aluminium made, highly polished and hard black anodized with a spliced Dyneema™ snap-loop. A safety spring prevents the line from going out. Spare Dyneema™ Loops are available. Antal offers a special aluminium pad-eye (page 188) for Dyneema™ Loops.

DYNEEMA™ LOOP SAFETY FACTOR

(Breaking Load / Safe Working Load) = 3

MODEL	MAX LINE Ø mm	L mm	SWL kg	WEIGHT g
HK12	12	110	1500	80
HK16	16	120	2200	130



SECTORING

SECTORING

In 2008 Antal introduced the Low Friction Ring to the market, a product that revolutionized the line-handling on sailboats.

In 2020 Antal introduces **SectoRing**, the spinning ring with a guiding cover, small in size and low in weight, the perfect solution for high loads where large and fast movements are not required.

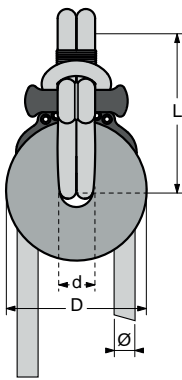

MOD. RS63.12

Always use Dyneema™ rope/ loops without a cover in the center hole to reduce friction, lines with cover should be used in the outer groove.

THE ANTAL SECTORING IS PATENT PENDING.

SIZE	MODEL	Ø mm	D mm	d mm	L mm	SWL* kg	WEIGHT g
S	RS43.08	8	43	8	50	1000	45
M	RS53.10	10	53	12	65	1700	80
L	RS63.12	12	63	15	80	2500	145
XL	RS76.14	14	76	20	100	3800	240

* The SWL (Safe Working Load) is **1/3** of the breaking load of the Antal Dyneema™ snap-loop.

	SIZE	MODEL	WEIGHT g
	S	RR43.08	35
	M	RR53.10	63
	L	RR63.12	107
	XL	RR76.14	174

	SIZE	MODEL	WEIGHT g
	S	LS2065	10
	M	LS2075	17
	L	LS2085	38
	XL	LS2105	66

SectoRing is also available without the Antal snap-loop where it can be used in custom fastening applications (in that case the SWL depends on the strength of the fastening but must not exceed Antal values).

Spare Dyneema™ snap-loops are available for each model. The loop connections should be checked for chafe on a regular basis, especially in case of fast and prolonged rotations under load which could cause the ring to overheat, resulting in possible damage of the loop.



SNAP-LOOPS

MINI

MINI SNAP-LOOP

It's a Dyneema™ loop that can be opened, with an easy and safe lock system. Three sizes with 2.5, 4 or 5 mm lines with different lengths. It will be used as a single, double or triple ring.

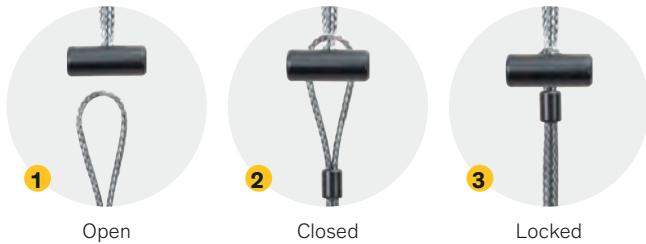

Open

Closed

Locked

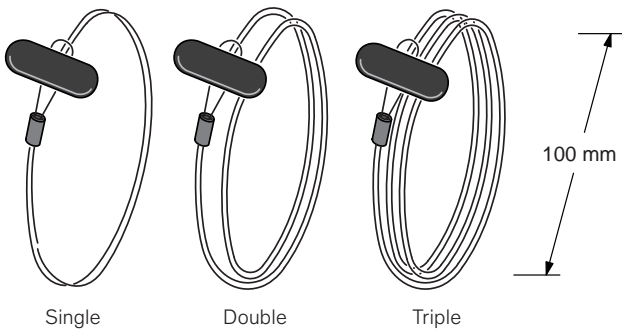

Single

Double

Triple

100 mm

MODEL	∅ cm	TOTAL LENGTH cm	TYPE	SWL kg
9001	2.5	20	single	250
SL4S	4	30	single	600
SL4D		50	double	1200
SL4T		70	triple	1800
SL5S	5	30	single	1000
SL5D		50	double	2000
SL5T		70	triple	3000



SNAP-LOOPS

AND DOG-BONES

SNAP-LOOPS WITHOUT COVER

These snap-loops are obtained with a spliced Dyneema™ line without a cover and an aluminium dog-bone. Suitable for Loper blocks (page 80).



MODEL	DYNEEMA™ Ø mm	BL kg	SWL kg	L mm	WEIGHT g
LS2060	4	3000	1000	100	11
LS2070	5	5200	1700	110	20
LS2080	6	6600	2200	125	44
LS2100	8	11000	3800	160	81

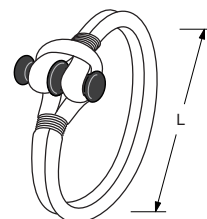

The Safe Working Load (SWL) is 1/3 of the breaking load, obtained from traction tests on a new loop.

SNAP-LOOPS WITH COVER

These snap-loops are obtained with a spliced Dyneema™ line with a polyester cover, an aluminium dog-bone and a locking sleeve. Suitable for Snatch Loper blocks (page 108).

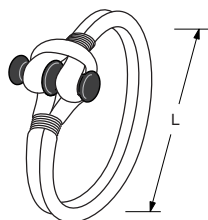

MODEL	DYNEEMA™ Ø mm	BL kg	SWL kg	L mm	WEIGHT g
LS2061	5	2800	900	110	15
LS2071	6	4800	1600	125	27
LS2081	8	6700	2200	150	51
LS2101	10	10500	3500	200	90

DOG-BONE

You can prepare your special snap-loop using Antal aluminium dog-bones, available separately.



MODEL	FOR DYNEEMA™ Ø mm	Ø mm	L mm	WEIGHT g
LS2062	4	6.5	30	3
LS2072	5	8.0	37	6
LS2082	6	10.0	46	13
LS2102	8	11.5	55	22
LS2122	10	13.5	67	36
LS2142	12	16.0	79	55

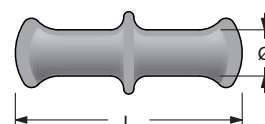



ACCESSORIES



Roller Cleat

202



Shackle and pad-eyes

204



Sliding pad-eyes

206



Model index

216

ROLLER CLEAT

MOD. RC290SI



MOD. RC290B



1



2



3



4

Roller is a folding cleat with rotating horns: with a simple gesture of your hand, you can open or close roller even with the line on, just by turning one of the horns.

→ **ROLLER IS OPEN:** you can easily tie or remove the mooring line.

→ **ROLLER IS CLOSED:** this position minimizes the size and, more important, prevents other lines from getting caught.

The horns can be shut down or turned up even under load. Roller is the only folding cleat you can close with the line on. Roller has perfectly rounded shapes in order not to damage the mooring lines.

Available in 4 sizes and 2 finishes: silver (**SI**) or black anodized (**B**). Mounting screws **included**.

SAFE WORKING LOAD

The SWL may differ according to the pull direction, depending on the type of mooring line used.

→ MOORING KNOT

The max. load changes with the line direction.

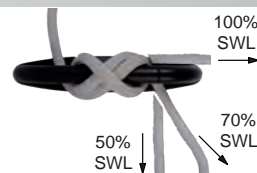

→ SPLICED LINE

The max. load remains the same for any line direction.

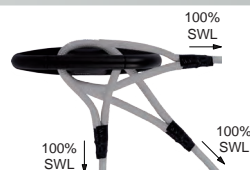

HORN ROTATION

The horn can only be rotated on one side (inward). In this way, Roller can act as a footrest (outward rotation is locked).

A safety ball keeps the cleat steady in the open or closed position.

ROTATION

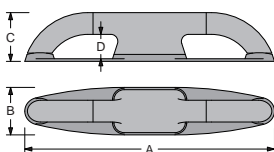
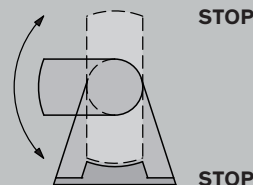

MODEL*	A mm	B mm	C mm	D mm	SWL kg	WEIGHT kg	SCREWS N x Ø mm	MAX LOA ft
RC230	232	46	46	21	2000	0.44	2 x Ø10 + 2 x Ø6	36
RC290	287	55	56	28	4000	0.77	2 x Ø14 + 2 x Ø6	46
RC350	346	64	65	31	7500	1.33	4 x Ø12 + 2 x Ø6	58
RC420	418	76	77	36	11500	2.30	4 x Ø14 + 2 x Ø8	70

* For black finishing add **B** to the model number, add **SI** for the silver.



PAD-EYES

NO WELDING

NO WELDING PAD-EYES

No Welding: no corrosion, guaranteed performances. No-Welding products guarantee absence of defects (cracks) and therefore maximum and constant performances. No Welding products avoid completely corrosion problems due to overheating.

The possibility of disassembly allows easy connections with spliced lines and joints. AISI316 S.Steel, highly polished pad eyes.

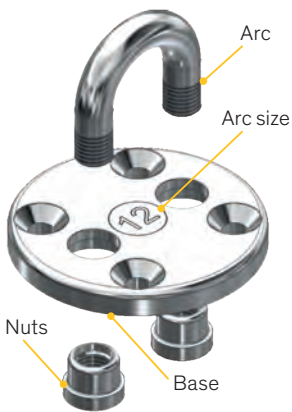

FIG. 1

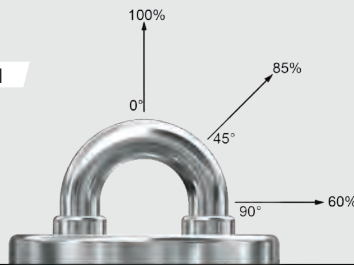
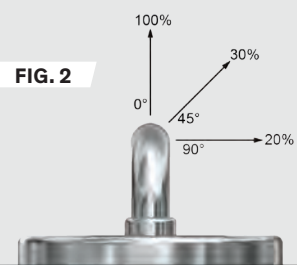

FIG. 2



The pad-eye should be positioned so that the direction of the main load is in the plane of the arc. For different load directions appropriate reduction of the SWL must be considered (see FIG.1).

Loads in the transverse plane can cause deformations of the arc therefore appropriate reductions of the SWL must be considered (FIG.2). However with side loads small deformations will always be possible.

PAD-EYES



These models, made in AISI316 S.Steel, are fixed to the deck with 2, 4 or 6 screws that guarantee the best distribution of the load, making them the right solution for heavy loads.

They can be fitted with a block and a stand-up spring.

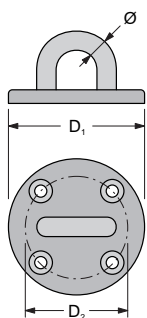

NEW

MODEL	Ø mm	D ₁ mm	D ₂ mm	SCREWS N x Ø mm	WEIGHT kg	SWL kg	FOR BLOCK Ø mm
7206	6	44.5	31	2 x Ø6	0.10	800	60
7208	8	65	49	4 x Ø6	0.16	1500	70
7210	10	75	53	4 x Ø8	0.26	2500	80
7212	12	80	59	4 x Ø8	0.38	3600	100
7214	14	99	74	4 x Ø10	0.68	4600	120
7216	16	110	84	6 x Ø10	1.10	6500	140 - 150
7220	20	129	104	6 x Ø10	1.80	9000	180

SCREWED EYEBOLTS

Made of AISI316 S.Steel. This solution allows an easy removal of the eyebolt from the deck. They can be fitted with a block and a "stand-up" spring.

Blocks with screwed eyebolts include: block with spring and (removable) eyebolt and the base (fixed to the deck).

The same base is suitable for blocks of different sizes: same base for 70 and 80 mm blocks, same for 100 and 120 mm blocks and one for 140, 150 and 180 mm.

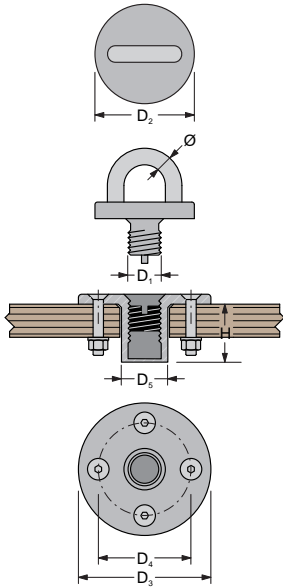

The small **MOD. 7306** is not build-in but is completely over the deck.



MOD. 7312



MOD. 7316

MODEL	Ø mm	D ₁ mm	D ₂ mm	D ₃ mm	D ₄ mm	D ₅ mm	H mm	SCREWS N x Ø mm	WEIGHT kg	SWL kg	FOR BLOCK Ø mm
7306	6	12	40	46	30	-	-	2 x Ø6	0.23	800	60
7308	8	20	50	70	50	28	35	4 x Ø6	0.56	1500	70
7310	10	20	60	80	56	28	35	4 x Ø8	0.58	2500	80
7312	12	24	78	90	64	32	38	4 x Ø10	0.72	3600	100
7314	14	24	70	90	64	32	38	4 x Ø10	1.09	4600	120
7316	16	30	84	120	92	42	56	6 x Ø10	2.20	6500	140 - 150
7321	20	36	100	120	92	46	56	6 x Ø10	3.60	9000	180

Do not use Antal pad-eyes for boat lifting.



PAD-EYES

SLIDING

SLIDING PAD-EYE

A sliding pad-eye with two positions:

- **OPEN:** for a Dyneema™ line connection or an HR shackle 10 mm connection;
- **CLOSED:** to offer a completely flush deck.

Made from highly polished AISI316 S.Steel.

WEIGHT – 850 g

SWL – 3500 kg

SAFE WORKING LOAD (SWL)

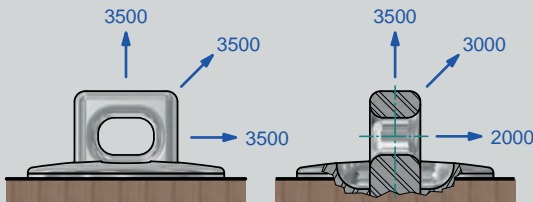

Do not use Antal sliding pad-eyes for boat lifting.

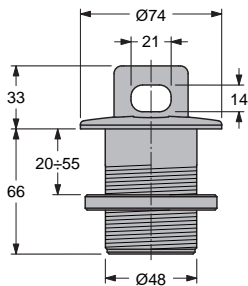

Drill a $\text{Ø}48$ mm hole (A) on a reinforced area of the deck. Center washer (B) on the hole and turn it so that the pad-eye is along the direction of the maximum load.

Put some sealant under the washer and fix it with the 4 self-tapping screws (C) (first drill 4 holes of $\text{Ø}3$ mm – D). Put some sealant on the washer and insert cylinder (E) into the hole. Rotate the cylinder until it enters the square hole of the washer.

Lock the cylinder by screwing ring-nut (F) from under the deck. The ring-nut is provided with two threaded holes for $\text{Ø}5$ mm screws (not supplied) that can be used for strong tightening.

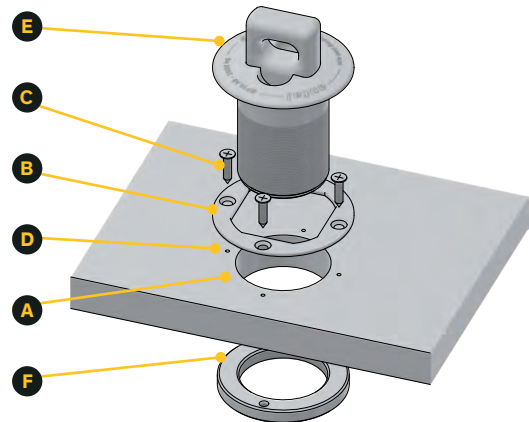

SHACKLES AND U-BOLTS

SHACKLES AISI316 AND HR

Antal supplies standard shackles made in AISI316 and HR high resistance S.Steel. The HR version offers higher values of the Safe Working Load.

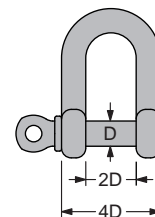

AISI316 MODEL	D mm	BL kg	SWL kg	ANTAL BLOCKS Ø mm	HR MODEL	D mm	BL kg	SWL kg	ANTAL BLOCKS Ø mm
005SS	5	1200	600	50	-	-	-	-	-
006SS	6	1600	800	60	006HR	6	2600	1300	70
008SS	8	2700	1300	-	008HR	8	4700	2200	80
010SS	10	4300	1900	-	010HR	10	7500	3500	100
012SS	12	6000	2600	-	012HR	12	10900	5000	120
014SS	14	8000	3500	-	014HR	14	13000	6500	140 - 150

Breaking Load and Safe Working Load are indicative as each manufacturer declares different values.



Ciolita – Ph. J.R.Taylor

U-BOLTS

Made of AISI316 S.Steel. They can be fitted with a block and a "stand-up" spring.

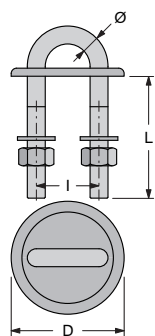

MODEL	Ø mm	I mm	D mm	L mm	WEIGHT kg	SWL kg	FOR BLOCK Ø mm
7105	5	17	38	50	0.05	500	50
7106	6	22	44	55	0.06	800	60
7108	8	28	54	67	0.13	1500	70
7110	10	35	63	67	0.17	2500	80

Do not use Antal U-Bolt for boat lifting.



Products are continuously improved and Antal reserves the right to modify them without notice. Antal has no responsibility for possible mistakes in this catalogue.

Antal is a registered trade-mark.



CUSTOM

Custom products are designed, produced and tested on request.



PRODUCTS INFO

User guides, drilling templates, exploded views and other drawings are available on our website.



CAD LIBRARY

Our CAD Library is easily accessible from our website www.antal.it.



CATALOGUE

Printed at Centrooffset (Padova, Italy) during October 2024.



SOCIAL MEDIA

Follow us on Facebook, Instagram, LinkedIn and YouTube, search for @antal.sailing!



ANTAL TRACKS

FULL BATTEN MAST TRACKS

Material & finish: hard black anodized and Teflon-coated aluminium.

Silver finish only on request.



FOR SLIDERS WITH HS FIBRE GUIDES OR FIBREBALL SLIDERS

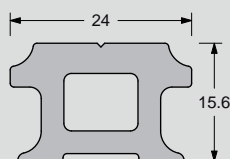

24x16 mm

FASTENERS – Ø6 mm screws
LENGTH – 2 or 3 m
Mounting slugs available
(page 165)

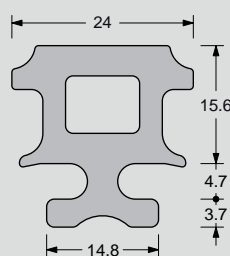

24x16 mm

MAST GROOVE 4x15 mm
NO FASTENERS
LENGTH – 3 m
(page 165)

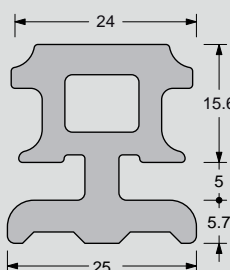

24x16 mm

MAST GROOVE 6x25 mm
NO FASTENERS
LENGTH – 3 m
(page 165)

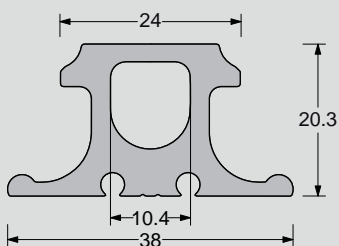

24x20 mm

LENGTH – 3 m
Profile to be glued
(page 175)

FOR FIBREBALL SLIDERS

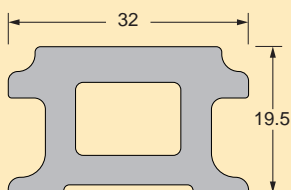

32x20 mm

FASTENERS – Ø8 mm screws
LENGTH – 3 m
Mounting slugs available
(page 177)

NEW

FOR SLIDERS WITH PLASTIC OR HS FIBRE GUIDES

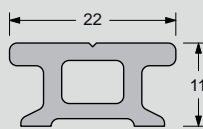

22x11 mm

FASTENERS – Ø5 mm screws
LENGTH – 2 or 3 m
Mounting slugs available
(page 172)

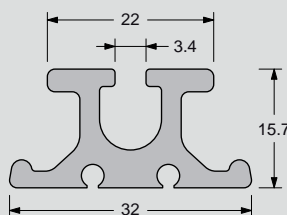

22x16 mm

LENGTH – 3 m
Profile to be glued
(page 173)

FOR SLIDERS WITH HS FIBRE GUIDES

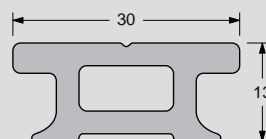

30x13 mm

FASTENERS – Ø6 mm screws
LENGTH – 3 or 6 m
No slugs available (page 176)

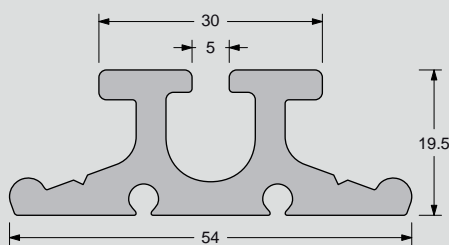

30x20 mm

LENGTH – 3 m
Profile to be glued (page 176)

T-TRACKS

Material and finish: hard black or silver anodized and Teflon-coated aluminium.

T-Tracks for sliders with plastic guides.

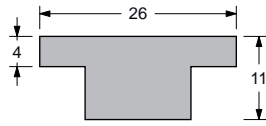

26×4 mm

FASTENERS – Ø5 mm screws
Any length up to 3 m (page 112)

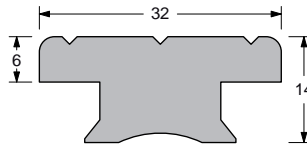

32×6 mm

FASTENERS – Ø6 mm screws
Any length up to 6 m (page 114)

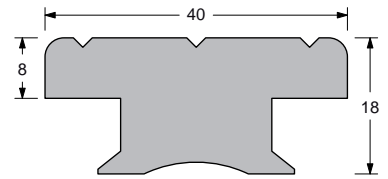

40×8 mm

FASTENERS – Ø8 mm screws
Any length up to 6 m (page 116)

MATERIAL AND FINISH: POLISHED 316 STAINLESS STEEL

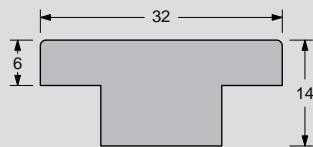

32×6 mm

FASTENERS
Ø6 mm screws
Any length up to 6 m
(page 120)

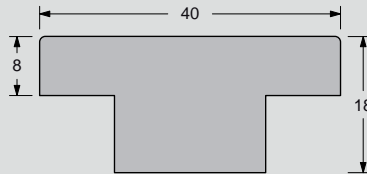

40×8 mm

FASTENERS
Ø8 mm screws
Any length up to 6 m
(page 120)

4RACE TRACKS

Material and finish: hard black anodized and Teflon-coated aluminium.

Silver finish only on request.
4Race tracks for ball bearings sliders.

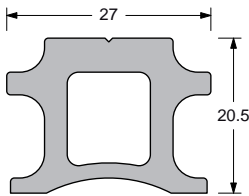

27×20 mm

FASTENERS – Ø5 mm screws
Any length up to 3 m (page 129)

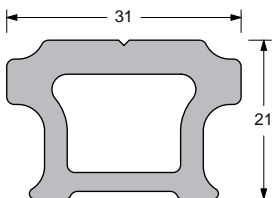

31×21 mm

FASTENERS – Ø8 mm screws
Any length up to 6 m (page 132)

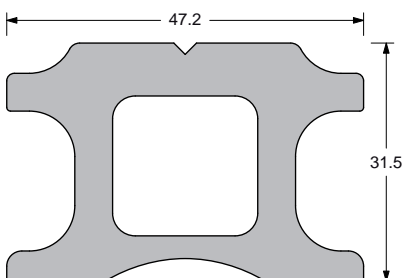

47×31.5 mm

FASTENERS – Ø10 mm screws
Any length up to 6 m (page 146)

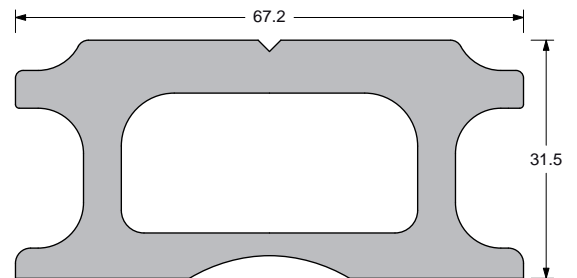

67×31.5 mm

FASTENERS – Ø12 mm screws
Any length up to 6 m (page 150)

31×60 mm

FASTENERS – Ø8 mm screws
on sliding slugs
Any length up to 6 m (page 132)

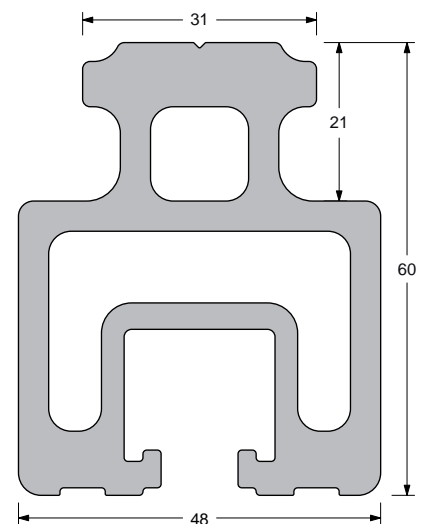

BLOCK SYSTEMS

TAB. A STANDARD SYSTEMS

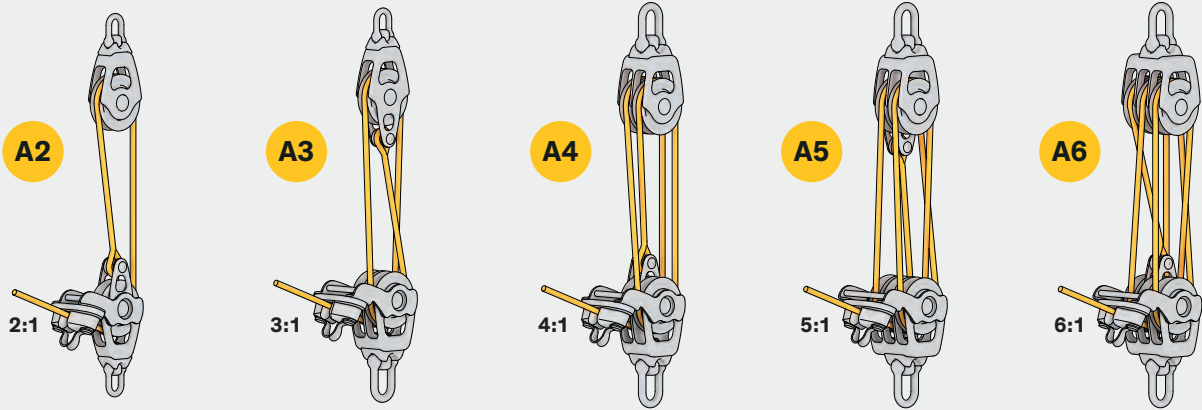

TAB. B FIDDLE SYSTEMS

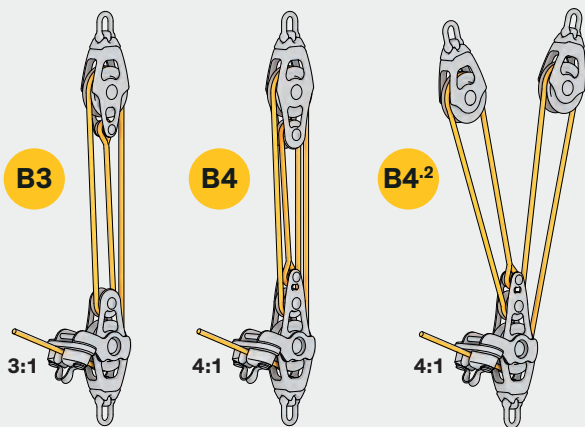

TAB. C CHAIN SYSTEMS FOR VANG AND BACKSTAY

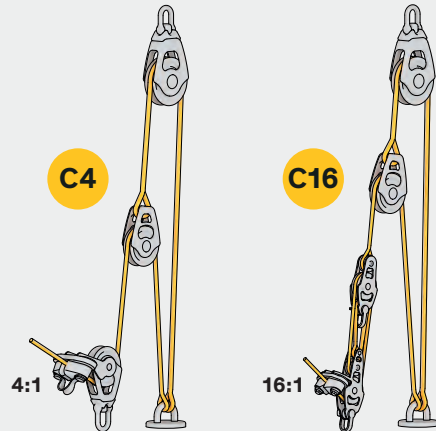

TAB. D BLOCKS SYSTEM FOR VANG AND BACKSTAY

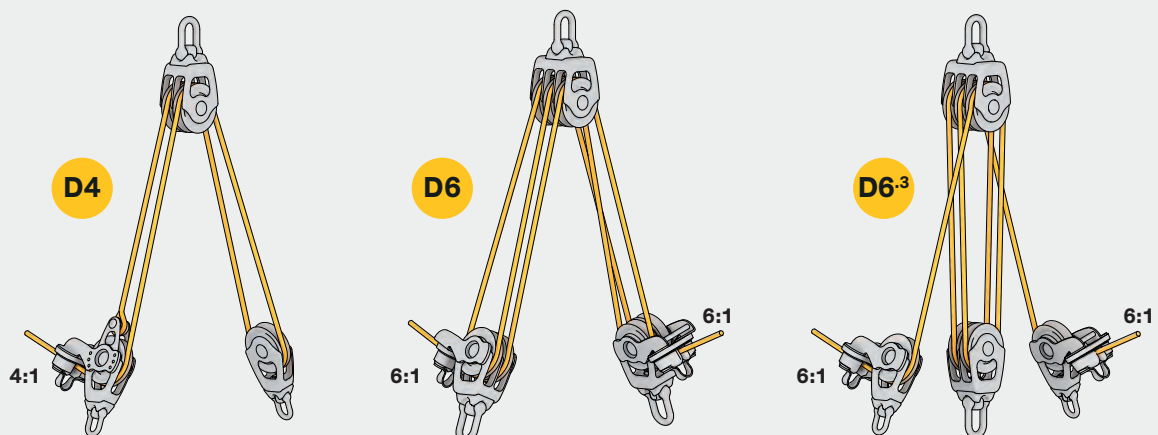

TAB. E

SINGLE SPEED MAIN SHEET SYSTEMS

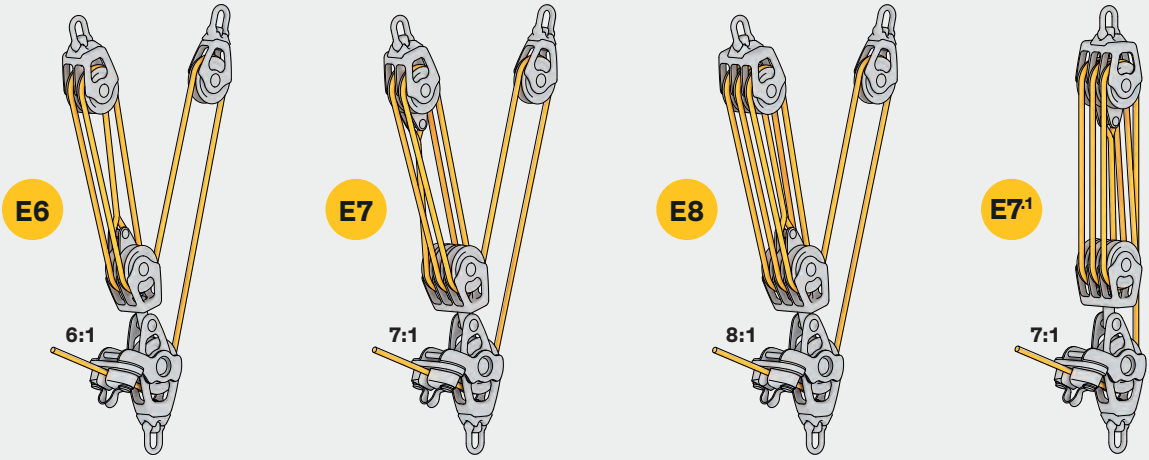

TAB. F

DOUBLE SPEED MAIN SHEET SYSTEMS

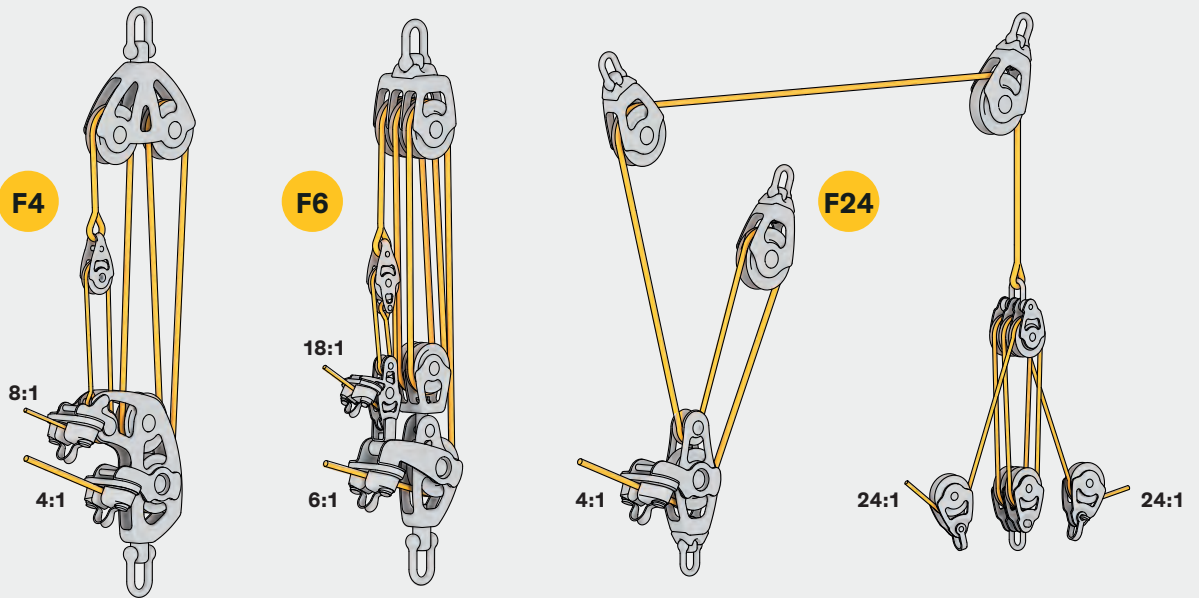

TAB. G

DOUBLE SPEED SYSTEM

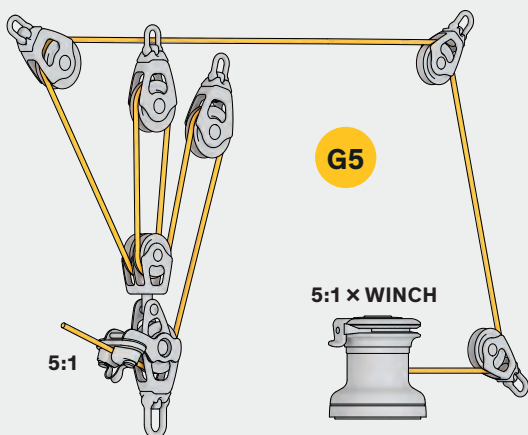

RIGGING LOADS

BREAKING LOADS

Reported breaking loads are average values: real values may vary greatly according to the supplier. Working loads will be obtained with appropriate safety factors: **1/2** for steel wire, **1/4** for rope.

POLYESTER cover and core			
Ø	BL	Ø	BL
mm	kg	inch	lb
4	450	5/32	1000
5	600	3/16	1300
6	750	1/4	1650
8	1300	5/16	2850
10	2100	3/8	4600
12	2900	1/2	6400
14	3900	9/16	8600
16	5000	5/8	11000
18	6200	11/16	13600
20	7500	13/16	16500
22	9000	7/8	19800

POLYESTER cover DYNEEMA™ core			
Ø	BL	Ø	BL
mm	kg	inch	lb
4	700	5/32	1550
5	1000	3/16	2200
6	1800	1/4	3950
8	3000	5/16	6600
10	4600	3/8	10100
12	6600	1/2	14500
14	8900	9/16	19600
16	11000	5/8	24200

S.STEEL AISI316 1 × 19			
Ø	BL	Ø	BL
mm	kg	inch	lb
3	800	1/8	1700
4	1400	5/32	3100
5	2100	3/16	4600
6	3100	1/4	6800
7	4100	9/32	9100
8	5200	5/16	11400
10	8000	3/8	17600
12	11000	1/2	24200
14	14500	9/16	31900
16	19000	5/8	41900
18	23500	11/16	51800

S.STEEL AISI316 7 × 19			
Ø	BL	Ø	BL
mm	kg	inch	lb
3	550	1/8	1200
4	900	5/32	2000
5	1500	3/16	3300
6	2200	1/4	4800
7	2900	9/32	6400
8	3800	5/16	8400
10	6000	3/8	13200
12	8500	1/2	18700

BREAKING LOADS

BL ↘	TENSILE STRESS	SHEARING STRESS
D	BL	BL
mm	kg	kg
5	1000	600
6	1400	800
8	2600	1500
10	4000	2400
12	5600	3300
14	7600	4600

Screws AISI316 class 50.

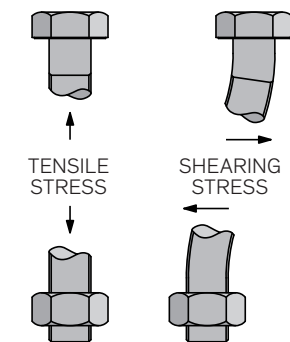

CONVERSION FACTOR

mm → inch × 25.4
cm → inch × 2.54
cm → ft × 30.48
m → ft × 0.305
m² → ft² × 0.093
gr → oz. × 28.35
kg → lb × 0.454

inch → mm × 0.039
inch → cm × 0.394
ft → cm × 0.033
ft → m × 3.281
ft² → m² × 10.76
oz. → gr × 0.035
lb → kg × 2.205

SWL is the abbreviation of Safe Working Load, it is half of the Breaking Load (BL).

BLOCK LOADING

Block loading depends on the angle of the line. Values for typical angles are reported in the table.

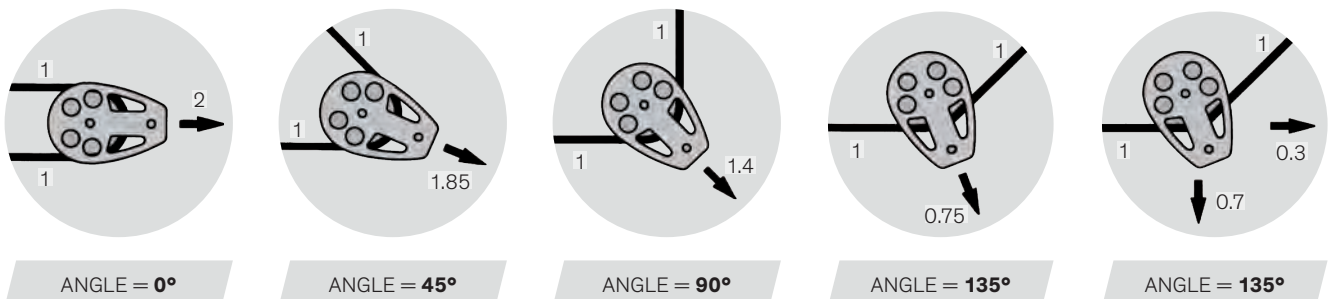

PARAGLIDE



KITE



TENSOSTRUCTURE



RESCUE



ARBORIST



WOT ONLY FOR SAILING



MODEL INDEX

MODEL	PAGE	MODEL	PAGE	MODEL	PAGE	MODEL	PAGE
0							
00301.....	59	00517.....	64	00802.....	70	01409.....	73
00302.....	59	00518.....	95	00803.....	70	01410.....	73
00303.....	59	005SS.....	207	00803J2.....	137	01411.....	73
00304.....	59	00601.....	66	00807.....	70	01412.....	73
00305.....	59	00601J.....	130	00808.....	70	01414.....	73
00306.....	59	00602.....	66	00809.....	70	01415.....	73
00311.....	59	00603.....	66	00810.....	70	01418Z.....	95
00316.....	59	00604.....	66	00811.....	70	014HR.....	207
00318D.....	95	00605.....	66	00812.....	70	014SS.....	207
00320.....	59	00606.....	66	00813.....	70	03411M.....	58
00321.....	59	00607.....	66	00814.....	70	03413M.....	59
00322.....	59	00608.....	66	00815.....	70	04013M.....	58
00323.....	59	00609.....	66	00816.....	70	04514M.....	60
00324.....	59	00610.....	66	00818.....	95	04919F.....	62
00330.....	59	00611.....	67	00818Z.....	95	05114M.....	62
00331.....	59	00612.....	67	00819.....	94	06016F.....	62
00401.....	60	00613.....	67	00821.....	93	06421F.....	62
00401B.....	61	00614.....	67	008HR.....	207	07016F.....	62
00402.....	60	00615.....	67	008SS.....	207	07016R.....	102
00402B.....	61	00616.....	67	01001.....	71	07116R.....	102
00403.....	60	00617.....	67	01001J2.....	137	08019F.....	62
00404.....	60	00618.....	95	01002.....	71	08019R.....	102
00405.....	60	00619.....	94	01003.....	71	08119R.....	102
00406.....	60	00621.....	93	01007.....	71		
00411.....	60	00621C.....	93	01008.....	71	1	
00416.....	60	00631C.....	74	01009.....	71	10021A.....	62
00418.....	95	00632C.....	74	01010.....	71	10021R.....	102
00418D.....	95	00633C.....	74	01011.....	71	10121R.....	102
00420.....	60	006HR.....	207	01012.....	71	12025A.....	62
00421.....	60	006SS.....	207	01014.....	71	14025A.....	62
00422.....	60	00701.....	68	01015.....	71	15029A.....	76
00423.....	60	00702.....	68	01016.....	71	18035A.....	76
00424.....	60	00703.....	68	01018.....	95		
00430.....	60	00704.....	68	01019.....	94	2	
00430B.....	61	00705.....	68	01018Z.....	95	2011.....	34
00431.....	60	00706.....	68	01021.....	93	2012.....	34
00431B.....	61	00707.....	68	010HR.....	207	2014.....	34
00501.....	64	00708.....	68	010SS.....	207	2021.....	34
00502.....	64	00709.....	68	01021D.....	93	2022.....	34
00503.....	64	00710.....	68	01201.....	72	2023.....	34
00504.....	64	00711.....	69	01202.....	72	2031.....	34
00505.....	64	00712.....	69	01209.....	72	2032.....	34
00506.....	64	00713.....	69	01210.....	72	2033.....	34
00507.....	64	00714.....	69	01211.....	72	2121.....	35
00507/9.....	65	00715.....	69	01212.....	72	2122.....	35
00508.....	64	00716.....	69	01214.....	72	2123.....	35
00508/9.....	65	00717.....	69	01215.....	72	21843A.....	76
00509.....	65	00718.....	95	01216.....	72	240.010.....	31
00510.....	65	00718Z.....	95	01216Z.....	72	24856A.....	76
00511.....	64	00731C.....	74	01218.....	95	251.035AG.....	21
00512.....	64	00732C.....	74	01218Z.....	95	251.035AR.....	21
00513.....	65	00733C.....	74	012HR.....	207	251.035QG.....	21
00516.....	64	00801.....	70	012SS.....	207	251.035QR.....	21
		00801J1.....	135	01401.....	73	251.035SG.....	21
		00801J2.....	136	01402.....	73	251.035SR.....	21

MODEL	PAGE
4	
4100.....	130
4100F.....	139
4101.....	130
4102.....	130
4102SH.....	129
4103.....	130
4110.....	134
4110D.....	140
4110F.....	139
4110SH.....	132
4112.....	134
4113.....	134
4114.....	134
4118.....	153
4119SP.....	153
4123.....	137
4124.....	137
4127.....	137
4150C.....	143
4150D.....	140
4150F.....	139
4150SH.....	132
4153.....	135
4154.....	135
4155.....	135
4190D.....	140
4190F.....	139
4190H.....	123
4190SH.....	132
4194.....	136
4195.....	136
4196.....	136
4199.....	136
4230D.....	140
4260H.....	123
4261.....	129
4262.....	129
4263.....	129
4264.....	129
4266.....	129
4271.....	133
4271B.....	153
4272.....	133
4273.....	133
4273Z.....	138
4274.....	133
4274G.....	142
4274Z.....	142
4275.....	133
4275Z.....	137
4276.....	133
4283.....	153
4291.....	133
4410.....	133
4410Z.....	137
4420.....	133
4430.....	133
4510.....	132
4520.....	132
4523.....	153
4530.....	132
4540.....	132

MODEL	PAGE
4541.....	132
4543.....	132
4550.....	132
4560.....	123
4601.....	131
4603.....	131
4623.....	142
4651.....	142
4654.....	142
4691.....	142
4694.....	142
5	
500.110.....	41
500.120.....	41
500.130.....	41
500.210.....	41
501.110.....	41
501.120.....	41
501.130.....	41
501.210.....	41
502.011.....	54
502.022.....	54
502.033.....	54
502.22/37.....	54
505.081.....	51
505.082.....	51
505.083.....	51
505.085.....	51
505.086.....	51
505.087.....	51
505.101.....	51
505.102.....	51
505.103.....	51
505.105.....	51
505.106.....	51
505.107.....	51
505.121.....	51
505.122.....	51
505.123.....	51
505.125.....	51
505.126.....	51
505.127.....	51
505.141.....	51
505.142.....	51
505.143.....	51
505.145.....	51
505.146.....	51
505.147.....	51
505.161.....	51
505.162.....	51
505.163.....	51
505.165.....	51
505.166.....	51
505.167.....	51
505.181.....	51
505.182.....	51
505.183.....	51
505.185.....	51
505.186.....	51
505.187.....	51
506.101.....	49
506.103.....	49
506.106.....	49

MODEL	PAGE
506.121.....	49
506.123.....	49
506.126.....	49
506.141.....	49
506.143.....	49
506.146.....	49
507.111.....	52
507.112.....	52
507.113.....	52
507.121.....	52
507.122.....	52
507.131.....	52
507.132.....	52
508.114.....	47
508.116.....	47
508.118.....	47
508.120.....	47
508.121.....	47
508.122.....	47
508.122P.....	47
508.123.....	47
508.141.....	47
508.142.....	47
508.143.....	47
508.161.....	47
508.162.....	47
508.163.....	47
509.111.....	43
509.111H.....	43
509.112.....	43
509.112H.....	43
509.113.....	43
509.113H.....	43
509.121.....	43
509.122.....	43
509.123.....	43
509.131.....	43
509.132.....	43
509.133.....	43
509.141.....	43
509.142.....	43
509.143.....	43
512.111.....	45
512.111H.....	45
512.112.....	45
512.112H.....	45
512.113.....	45
512.113H.....	45
512.121.....	45
512.122.....	45
512.123.....	45
512.131.....	45
512.132.....	45
512.133.....	45
512.141.....	45
512.142.....	45
512.143.....	45
513.032.....	53
513.110.....	41
513.120.....	41
513.130.....	41
513.210.....	41
514E.....	41
514F.....	41

MODEL	PAGE
514I.....	41
514.032.....	53
515.032.....	53
516.032.....	53
517.032.....	53
5194.....	138
5197.....	138
522.022.....	54
522.031.....	53
522.140.....	54
523.042.....	53
523.052.....	53
524.042.....	53
524.052.....	53
525.042.....	53
525.052.....	53
526.042.....	53
526.052.....	53
533.032.....	53
534.032.....	53
535.032.....	53
536.032.....	53
540.110.....	41
540.120.....	41
540.130.....	41
540.210.....	41
541.110.....	41
541.120.....	41
541.130.....	41
541.210.....	41
543.110.....	41
543.120.....	41
543.130.....	41
543.210.....	41
549.111.....	43
549.111H.....	43
549.112.....	43
549.112H.....	43
549.113.....	43
549.113H.....	43
549.121.....	43
549.122.....	43
549.123.....	43
549.131.....	43
549.132.....	43
549.133.....	43
549.141.....	43
549.142.....	43
549.143.....	43
6	
601.121.....	129
601.123.....	146
601.123R.....	146
601.124.....	150
601.221.....	129
601.223.....	146
602.112.....	120
602.112B.....	120
602.112S.....	120
602.113.....	120
602.113B.....	120
602.113S.....	120
602.211.....	120



HH 6601 Cat

MODEL	PAGE	MODEL	PAGE	MODEL	PAGE	MODEL	PAGE		
813.154.....	77	851.065.....	55	940.225.....	79	C	C001.....	29	
813.184.....	78	851.080.....	55	940.255.....	79		C002.....	29	
815.075.....	91	851.100.....	55	940.304.....	79		C003.....	29	
815.090.....	91	851.125.....	55	941.154.....	77		C004.....	29	
815.120.....	91	852.065.....	55	941.184.....	78		C005.....	29	
815.150.....	91	852.080.....	55	941.224.....	79		C006.....	29	
815.180.....	91	852.100.....	55	941.254.....	79	D	D3008.....	191	
815.452.....	91	852.125.....	55	949.502.....	115		D3610.....	191	
815.552.....	91	9	9001.....	104	949.552S.....		124	D420.....	96
815.652.....	91		9030.....	104	950.224.....		78	D430.....	96
816.075.....	92		9030Y.....	104	950.254.....		79	D440.....	96
816.090.....	92		9031.....	104	950.304.....		79	D450.....	96
816.120.....	92		9040.....	106	981.154.....		77	D460.....	96
816.150.....	92		9060.....	106	991.073.....		100	D520.....	96
816.180.....	92		908.095.....	109	991.093.....		100	D530.....	96
817.050.....	99		908.125.....	109	991.124.....		100	D540.....	96
817.060.....	99		909.502.....	115	991.154.....		100	D550.....	96
817.071.....	99		909.552S.....	124	991.184.....		100	D560.....	96
817.090.....	99		910.155Z.....	77	992.602.....		75	D620.....	96
818.050.....	99		910.185.....	78	992.603.....		75	D630.....	96
818.060.....	99		910.225.....	79	993.603.....		75	D640.....	96
818.070.....	99		910.255.....	79	994.055.....		100	D650.....	96
818.090.....	99		911.154.....	77	994.065.....		100	D660.....	96
819.045.....	98		911.184.....	78	994.075.....		100	D670.....	96
819.060.....	98		911.224.....	79	994.085.....		100	D680.....	96
819.070.....	98		911.254.....	79	994.095.....		100	D720.....	96
819.090.....	98	911.304.....	79	994.125.....	100	D730.....	96		
819.110.....	98	918.095.....	109	A	A041.....	21	D740.....	96	
821.050.....	97	918.125.....	109		A051.....	21	D750.....	96	
821.052.....	96	918.155.....	109		A071.....	21	D760.....	96	
821.062.....	96	922.602.....	75		A101.....	21	DBL44.....	105	
821.070.....	97	928.095.....	109		A151.....	21	DBL56.....	105	
821.074.....	96	928.125.....	109	B	BB4012.....	107	DBS04.....	105	
821.100.....	97	928.155.....	109		BB6014.....	107	DBS05.....	105	
831.154.....	77	940.155Z.....	77						
831.184.....	78	940.185.....	78						
832.154.....	77								
832.184.....	78								

MODEL	PAGE
DBS44.....	105
DBS56.....	105
DS06.....	187
DS08.....	187
DS10.....	187
E	
E6/60.....	74
E6/75.....	74
E7/60.....	74
E7/75.....	74
E8/60.....	74
E8/75.....	74
F	
F4/8.....	75
F4/12.....	75
F6.....	75
FB24.120D.....	168
FB24.120J.....	168
FB24.120JA.....	167
FB24.121.....	167
FB24.60D.....	166
FB24.60J.....	166
FB24.60S.....	166
FB24.90D.....	167
FB24.90J.....	167
FB32.100S.....	169
FB32.11.....	177
FB32.12.....	177
FB32.13.....	177
FB32.160D.....	169
FB32.160DX.....	170
FB32.200DX.....	170
FB32.160J.....	169
FB32.160JA.....	169
FB32.311.....	177
FB32.321.....	177
FB32.90.....	170
H	
H020.....	101
H030.....	101
H040.....	101
H050.....	101
H130.....	101
H140.....	101
H150.....	101
H160.....	101
HDR.....	6
HK12.....	196
HK16.....	196
HS22.01.....	173
HS22.02.....	173
HS22.03.....	173
HS22.05.....	173
HS22.06.....	178
HS22.09.....	178
HS22.100JAR.....	158
HS22.110.....	159
HS22.11.....	172
HS22.12.....	172
HS22.13.....	172
HS22.15.....	172

MODEL	PAGE
HS22.16.....	177
HS22.165.....	183
HS22.17.....	183
HS22.185.....	183
HS22.221.....	172
HS22.222.....	172
HS22.27.....	183
HS22.311.....	172
HS22.312.....	172
HS22.321.....	172
HS22.322.....	172
HS22.330.....	173
HS22.40D.....	157
HS22.40DR.....	157
HS22.40J.....	157
HS22.40JR.....	157
HS22.40S.....	157
HS22.40SR.....	157
HS22.44.....	157
HS22.46.....	157
HS22.49.....	157
HS22.50DR.....	158
HS22.50JR.....	158
HS22.50SR.....	158
HS22.60JR.....	159
HS22.60TR.....	159
HS22.70JAR.....	157
HS22.70JR.....	158
HS22.90JR.....	159
HS22F05.....	172
HS22F08.....	172
HS22F10.....	172
HS22F12.....	172
HS22F14.....	172
HS22R04.....	172
HS22R05.....	172
HS24.02.....	175
HS24.03.....	175
HS24.04.....	175
HS24.05.....	175
HS24.06.....	175
HS24.110JA.....	160
HS24.11.....	174
HS24.12.....	174
HS24.13.....	174
HS24.15.....	174
HS24.16.....	174
HS24.17.....	182
HS24.18.....	182
HS24.210.....	182
HS24.210R.....	182
HS24.221.....	174
HS24.222.....	174
HS24.311.....	174
HS24.312.....	174
HS24.321.....	174
HS24.322.....	174
HS24.350.....	175
HS24.50D.....	160
HS24.50J.....	160
HS24.50S.....	160
HS24.54.....	158
HS24.56.....	158
HS24.59.....	158

MODEL	PAGE
HS24.60J.....	161
HS24.60T.....	161
HS24.61.....	182
HS24.64.....	159
HS24.66.....	159
HS24.69.....	159
HS24.70J.....	162
HS24.70Q.....	162
HS24.74.....	162
HS24.76.....	162
HS24.79.....	162
HS24.90DX.....	183
HS24.90DY.....	183
HS24F05.....	174
HS24F06.....	174
HS24F08.....	174
HS24F10.....	174
HS24F12.....	174
HS24F14.....	174
HS24R04.....	174
HS24R06.....	174
HS30.01.....	176
HS30.02.....	176
HS30.03.....	176
HS30.05.....	176
HS30.09.....	178
HS30.110J.....	163
HS30.116.....	163
HS30.11.....	176
HS30.12.....	176
HS30.120JA.....	163
HS30.130J.....	164
HS30.13.....	176
HS30.16.....	178
HS30.313.....	176
HS30.313R.....	176
HS30.330.....	176
HS30.70Q.....	163
HS30.70S.....	163
HS30.74.....	163
HS30.76.....	163
HS30.79.....	163
HS30.90DX.....	183
HS30.90DY.....	183
HS30.90J.....	163
HS30.90Q.....	164
J	
JB06.....	145
JB08.....	145
JB10.....	145
JB12.....	145
JB14.....	145
L	
LD1000.....	32
LD1500.....	32
LD1500HD.....	32
LD700.....	32
LL046.....	108
LL054.....	108
LS046.....	108
LS054.....	108
LS1060.....	82

MODEL	PAGE
LS1061.....	82
LS1062.....	82
LS1063.....	82
LS1070.....	82
LS1071.....	82
LS1072.....	82
LS1073.....	82
LS1080.....	82
LS1081.....	82
LS1082.....	82
LS1083.....	82
LS1100.....	83
LS1101.....	83
LS1120.....	83
LS1121.....	83
LS1140.....	83
LS1141.....	83
LS2060.....	199
LS2061.....	199
LS2062.....	199
LS2065.....	197
LS2070.....	199
LS2071.....	199
LS2072.....	199
LS2075.....	197
LS2080.....	199
LS2081.....	199
LS2082.....	199
LS2085.....	197
LS2085/99.....	170
LS2100.....	199
LS2101.....	199
LS2102.....	199
LS2105.....	197
LS2105/99.....	170
LS2121.....	83
LS2122.....	199
LS2141.....	83
LS2142.....	199
LS2145/99.....	170
P	
P10.20.....	178
P14.25.....	178
P14.35.....	178
P14.42.....	178
R	
R07.05.....	192
R10.07.....	192
R12.25.....	190
R14.10.....	192
R14.14.....	190
R14.14S.....	190
R18.36.....	190
R20.14.....	192
R20.20.....	190
R20.20S.....	190
R2.14.....	191
R22.44.....	193
R28.20.....	192
R30.56.....	193
R3.14.....	191
R34.64.....	193

MODEL	PAGE
R38.28	192
R40.76	193
R4.14	191
R50.94	193
R50.120	193
R76.160	193
R5.14	191
R6.14	191
R7.14	191
RC230	202
RC290	202
RC350	202
RC420	202
RF14.30	194
RF16.35	194
RF18.40	194
RL3.0	196
RL4.0	196
RL4.5	196
RL5.0	196
RL6.0	196
RL6.1	196
RR43.08	197
RR53.10	197
RR63.12	197
RR76.14	197
RS43.08	197
RS53.10	197
RS63.12	197
RS76.12	170
RS76.14	197
RS88.14	170
RS140.16	170

S

SD06	195
SD08	195
SD10	195
S0601	85
S0602	85
S0603	85
S0604	85
S0605	85
S0606	85
S0609	85
S0611	85
S0612	85
S0613	85
S0614	85
S0615	85
S0616	85
S0701	86
S0702	86
S0703	86
S0704	86
S0705	86
S0706	86
S0711	86
S0712	86
S0713	86
S0714	86
S0715	86
S0731	86
S0732	86

MODEL	PAGE
S0901	87
S0902	87
S0903	87
S0904	87
S0905	87
S0906	87
S0911	87
S0912	87
S0914	87
S0915	87
S0931	87
S0932	87
S1201	88
S1202	88
S1203	88
S1204	88
S1211	88
S1212	88
S1214	88
S1215	88
S1231	88
S1232	88
S1501	89
S1502	89
S1511	89
S1512	89
S1514	89
S1515	89
S1531	89
S1532	89
S1801	90
S1802	90
S1811	90
S1812	90
S1814	90
S1815	90
S1831	90
S1832	90
SL4D	198
SL4S	198
SL4T	198
SL5D	198
SL5S	198
SL5T	198
SP10.48	206

T

T520	98
T530	98
T540	98
T550	98
T560	98
T620	98
T630	98
T640	98
T650	98
T660	98
TB4212	107
TD22.33	189
TD28.41	189
TL22.33	189
TL28.41	189
TT22.33	189
TT28.41	189

MODEL	PAGE
W	
W16	9
W30	9
W42	9
W5	8
W6	8
W7	8
W8	8
WBC	19

X

XT16.2	12
XT16.2R	24
XT16	12
XT16R	24
XT30.2	12
XT30.2R	24
XT30	12
XT30R	24
XT40	12
XT40EH	16
XT40R	24
XT44	12
XT44EH	16
XT44HD	20
XT44R	24
XT48	12
XT48EH	16
XT48HD	20
XT48R	24
XT52	12
XT52EH	16
XT52HD	20
XT52R	24
XT53.3RD	26
XT62.3	13
XT62.3EH	16
XT62.3HD	20
XT62.3R	25
XT62.3RD	25
XT62	12
XT62EH	16
XT62HD	20
XT62R	24
XT66.3	13
XT66.3EH	17
XT66.3EV	18
XT66.3HD	21
XT66.3R	25
XT66	13
XT66EH	17
XT66EV	18
XT66HD	21
XT66R	24
XT76	13
XT76EH	17
XT76EV	18
XT76HD	21
XT76.3	13
XT76.3EH	17
XT76.3EV	18
XT76.3HD	21
XT80.3	22

MODEL	PAGE
XT80.3EH	23
XT80.3EV	23
XT80.3HD	22
XT90.3	22
XT90.3EH	23
XT90.3EV	23
XT90.3HD	22
XTKIT	6

Y

Y-B0746	65
Y-B0747	65
Y-B0748	67
Y-B0749	67
Y-B0750	70
Y-B0751	71
Y-B0752	72
Y-B0846	73





LIMITED WARRANTY

Antal guarantees its equipment to be free of defects in material and workmanship for 3 years from the date of purchase. During this period defective parts will be repaired or replaced by Antal.

Warranty does not cover:

- products incorrectly installed;
- products used in applications for which they are not intended;
- products used under loads exceeding the product's stated loads;
- products not properly maintained.

Warranty does not cover defects due to corrosion, UV degradation, and normal wear and tear.

Products subject to warranty claim will be returned to Antal for examination and possible repairing or replacement. Antal is not responsible for installation or shipping costs.

MAINTENANCE

Remove salt deposits with fresh water; frequently washing will avoid corrosion that is activated from salt water. Grease (Hydrolub) or Loctite or anticorrosive product will protect aluminium; it will be useful to use some grease on S.Steel parts: screws, washers, pin to reduce the contact with aluminium.

Although all Antal products are made only with anti UV plastic it will be better to reduce the exposure to sunlight.

SOLAR PLANT

The new Antal photovoltaic solar plant with a surface of 500 m² and a power of 20 kw supply 20% of the energy necessary for the production.

Our passion for sailing is also care for the environment.







antal

Allen

ANTAL
Yacht

Jay Thompson

